

# **2 Printing Technologies with Permanent Printing Master**

## Contents Chapter 2

# Printing Technologies with Permanent Printing Master

<b>2.1</b>	<b>Offset Printing</b> .....	206	<b>2.1.6.2</b>	Web-fed Offset Printing Presses/Systems . . .	338
2.1.1	Basic Principles .....	206	2.1.7	Potential for Further Development .....	354
2.1.1.1	Process .....	206	2.1.7.1	Print Quality .....	354
2.1.1.2	Printing Plates, Printing Ink, Dampening Solution .....	209	2.1.7.2	Offset Printing Process .....	355
2.1.1.3	Inking Unit, Dampening Unit, Printing Unit .....	213	2.1.7.3	Drying .....	356
2.1.1.4	Print Quality .....	223	2.1.7.4	Automation .....	357
2.1.2	Sheet-fed Offset Printing .....	226	<b>2.2</b>	<b>Gravure Printing</b> .....	360
2.1.2.1	Paper Travel .....	226	2.2.1	Process .....	360
2.1.2.2	Feeders .....	229	2.2.1.1	Gravure Cylinder Manufacture .....	360
2.1.2.3	Printing Units .....	237	2.2.1.2	Gravure Cylinder Imaging .....	363
2.1.2.4	Sheet Reversal/Perfecting .....	244	2.2.1.3	Storage and Changing of Gravure Cylinders .....	366
2.1.2.5	Delivery .....	247	2.2.1.4	Impression Roller .....	368
2.1.2.6	Drying .....	251	2.2.1.5	Inking Unit and Doctor Blade .....	369
2.1.2.7	Print Enhancement and In-line Finishing . .	254	2.2.1.6	Drying .....	372
2.1.2.8	Press Architecture (Special Designs) .....	257	2.2.1.7	Circumferential and Lateral Register .....	372
2.1.3	Web-fed Offset Printing .....	260	2.2.1.8	Magazine Turner Bars Superstructure . . . .	374
2.1.3.1	Press and System Concepts (Components) .	260	2.2.1.9	Gravure Printing Folders .....	374
2.1.3.2	Web Travel (Infeed and Further Processing) .....	276	2.2.1.10	Reel Stand .....	377
2.1.3.3	Printing Unit .....	281	2.2.2	Examples of Gravure Printing Systems . . .	377
2.1.3.4	Folders and Print Product Variations .....	286	2.2.3	Gravure Printing in the Packaging Industry .....	384
2.1.3.5	Newspaper Printing .....	292	2.2.4	Potential for Further Development .....	391
2.1.4	Remote Control, Measurement and Control Technology/Systems .....	297	<b>2.3</b>	<b>Letterpress Printing</b> .....	395
2.1.4.1	Press Remote Control Systems .....	298	2.3.1	Basic Principles .....	395
2.1.4.2	Color Measurement and Control Systems . .	300	2.3.2	Letterpress Printing (Process and Applications) .....	396
2.1.4.3	Register Measurement and Control .....	307	2.3.3	Flexography .....	397
2.1.4.4	Inspection of the Printed Image .....	308	2.3.3.1	Process .....	397
2.1.4.5	In-line Print Quality Measurement and Control Systems .....	312	2.3.3.2	Printing Unit .....	401
2.1.4.6	The State of the Art in Remote Control, Measurement and Control Systems .....	317	2.3.3.3	Examples of Flexographic Printing Presses .....	404
2.1.5	Automation in Print Media Production . . .	319	2.3.4	Potential for Further Development .....	407
2.1.5.1	Wash-up Procedures .....	320	<b>2.4</b>	<b>Screen Printing</b> .....	409
2.1.5.2	Plate Changing .....	321	2.4.1	Basic Principles/Process .....	409
2.1.5.3	Sheet Size and Paper Travel Adjustment . . .	323	2.4.1.1	Platemaking .....	410
2.1.5.4	Ink Feed Presetting in the Printing Unit . . .	325	2.4.1.2	Printing Process .....	414
2.1.5.5	Ink and Dampening Solution Supply .....	328	2.4.2	Applications .....	416
2.1.5.6	Makeready for Print Production .....	329	2.4.2.1	Screen Printing on Flat Surfaces .....	416
2.1.6	Examples of Offset Printing Presses and Production Systems .....	333	2.4.2.2	Screen Printing on Curved Surfaces .....	417
2.1.6.1	Sheet-fed Offset Printing Presses .....	333	2.4.3	Examples of Machinery .....	417

2.4.3.1	Equipment and Machinery for Flat-bed Screen Printing .....	417	2.5.1.2	Postage Stamps, Stamps .....	429
2.4.3.2	Screen Printing Machinery for Printing on Curved Surfaces .....	418	2.5.1.3	Documents .....	432
2.4.3.3	Rotary Screen Printing Presses .....	418	2.5.2	Business Forms Printing .....	433
2.4.4	Potential for Further Development .....	422	2.5.3	Label Printing .....	438
2.5	<b>Special Printing Technologies and Product Specific Applications</b> .....	423	2.5.4	Pad Transfer Printing .....	442
2.5.1	Security Printing .....	423	2.5.4.1	Printing Process .....	443
2.5.1.1	Bank Notes .....	423	2.5.4.2	Cliche Making .....	445
			2.5.4.3	Pad, Ink, Object Holding Device .....	447
			2.5.4.4	Multicolor Pad Transfer Printing, Applications .....	447

## 2.1 Offset Printing

2.1.1	Basic Principles	206	2.1.4	Remote Control, Measurement and Control Technology/Systems	297
2.1.1.1	Process	206	2.1.4.1	Press Remote Control Systems	298
2.1.1.2	Printing Plates, Printing Ink, Dampening Solution	209	2.1.4.2	Color Measurement and Control Systems	300
2.1.1.3	Inking Unit, Dampening Unit, Printing Unit	213	2.1.4.3	Register Measurement and Control	307
2.1.1.4	Print Quality	223	2.1.4.4	Inspection of the Printed Image	308
2.1.2	Sheet-fed Offset Printing	226	2.1.4.5	In-line Print Quality Measurement and Control Systems	312
2.1.2.1	Paper Travel	226	2.1.4.6	The State of the Art in Remote Control, Measurement and Control Systems	317
2.1.2.2	Feeders	229	2.1.5	Automation in Print Media Production	319
2.1.2.3	Printing Units	237	2.1.5.1	Wash-up Procedures	320
2.1.2.4	Sheet Reversal/Perfecting	244	2.1.5.2	Plate Changing	321
2.1.2.5	Delivery	247	2.1.5.3	Sheet Size and Paper Travel Adjustment	323
2.1.2.6	Drying	251	2.1.5.4	Ink Feed Presetting in the Printing Unit	325
2.1.2.7	Print Enhancement and In-line Finishing	254	2.1.5.5	Ink and Dampening Solution Supply	328
2.1.2.8	Press Architecture (Special Designs)	257	2.1.5.6	Makeready for Print Production	329
2.1.3	Web-fed Offset Printing	260	2.1.6	Examples of Offset Printing Presses and Production Systems	333
2.1.3.1	Press and System Concepts (Components)	260	2.1.6.1	Sheet-fed Offset Printing Presses	333
2.1.3.2	Web Travel (Infeed and Further Processing)	276	2.1.6.2	Web-fed Offset Printing Presses/Systems	338
2.1.3.3	Printing Unit	281	2.1.7	Potential for Further Development	354
2.1.3.4	Folders and Print Product Variations	286	2.1.7.1	Print Quality	354
2.1.3.5	Newspaper Printing	292	2.1.7.2	Offset Printing Process	355
			2.1.7.3	Drying	356
			2.1.7.4	Automation	357

Offset printing is an indirect lithographic printing technology (see also [sec. 1.3.2.3](#)). Offset printing has spread markedly since approx. 1970 and has, to a great extent, ousted the letterpress printing technology which prevailed until that time. The offset printing technology is now the major printing technology.

### 2.1.1 Basic Principles

#### 2.1.1.1 Process

In the offset printing process the printing and non-printing areas of the plate are practically on one level. The printing areas of the printing plate are oleophilic/

ink-accepting and water-repellent, that is, hydrophobic. The non-printing areas of the printing plate are hydrophilic, consequently oleophobic in behavior. This effect is created by physical phenomena at the contact surfaces ([figs. 2.1-1](#) and [2.1-2](#)).

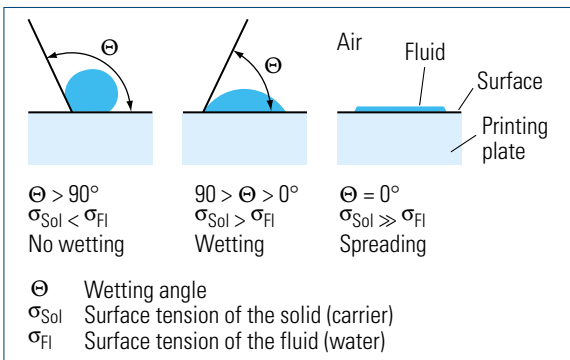
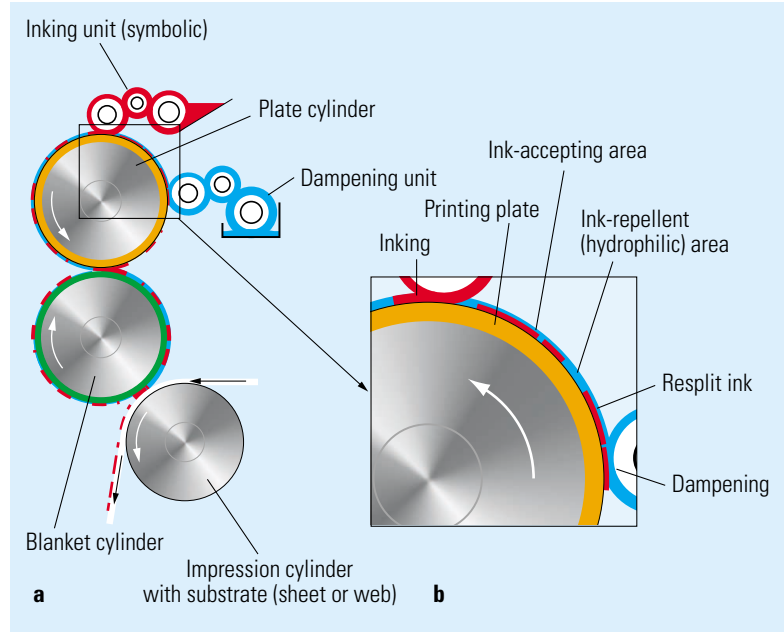
The dampening system covers the non-printing areas of the printing plate with a thin film of dampening solution. This dampening solution (water plus additives) spreads over the non-printing areas. To achieve good wetting, surface tension has to be reduced by means of dampening solution additives. In extreme cases, reducing the surface tension of the dampening solution too much can result in too great an emulsification of printing ink and dampening solution, leading to a situation

**Fig. 2.1-1**

Offset printing (lithography).

**a** Components of a printing unit;**b** Basic principle

(see also fig. 2.1-8)

**Fig. 2.1-2** Wettability of surfaces and wetting angles

where an exact separation of printing and non-printing areas on the plate is not achieved when inking.

The perfect offset printing process depends on many chemical and physical specifics of the materials and components involved in the process. The most important are given in the following list:

- *Influence of the printing plate*

- surface tension of the ink-accepting areas,
- surface tension of the dampening solution-accepting areas,

- surface roughness, especially of the ink-free/non-image surface,
- capillary attraction, microstructure of the non-image surface,
- type of materials,
- production methods in making the offset plate (mechanical or electrolytic graining, etc.);

- *Influence of the inking rollers*

- characteristics of the roller coverings,
- surface tension of the roller material,
- surface roughness,
- viscoelastic properties of the rubber coverings,
- throw-on (pressure in the nip), adjustment,
- concentric running;

- *Influence of the blanket*

- surface tension of the blanket,
- surface roughness,
- compressibility,
- ink acceptance and ink transfer behavior,
- tone value transfer behavior,
- setting/swelling, release behavior, hardness, dimensional stability;

- *Influence of the ink*

- surface tension, contact surface tension in relation to the dampening solution,
- rheological properties (viscosity, tack, etc.),
- temperature behavior,

- dampening solution absorption/emulsification behavior (leeway between smearing limit and water vanes),
- running clean behavior during start-up,
- ink composition,
- drying behavior;
- *Influence of the dampening solution*
  - water hardness/impurities,
  - dampening solution additives (alcohol, detergents, buffer agents),
  - pH value, surface tension,
  - rheological properties (viscosity, tack),
  - dependence on temperature of the rheological characteristics;
- *Influence of the substrate*
  - printability properties (smoothness, absorption capacity, wettability),
  - pH value of the substrate,
  - workability properties (tension/stretch behavior, picking, tearing);
- *Influence of the printing press* (on print quality and process stability)
  - design of the printing unit (accurate, stable, vibration absorbent, etc.),
  - design of the inking unit (front-heavy, back-heavy, free surface, little retroaction),
  - design of the dampening unit (contact dampening, non-contact dampening),
  - design of the ink feed system (ink metering),
  - temperature control.

This short overview shows that the offset printing technology must be viewed as a multiparameter system. Changing just one of the parameters can have an immediate effect on the printing process.

Offset printing is a technology that is clearly determined by interfacial processes, of both a physical and a chemical nature. The fact that homogeneous phases (e.g., pure water) are hardly ever involved in this process, and that more often than not it is a matter of mixed phases (e.g., water in which other substances have been dissolved) or even compound phases (e.g., printing ink, a dispersion of solid and fluid content) makes the understanding of how the various “partners” involved in this process interact more difficult.

To understand the actual mechanism of ink transfer in offset printing it must be taken into account that the contacting liquid films are always split in addition to the wetting process. Therefore, if a film of ink and a film of water come into contact with each other, the deci-

sive factor in the transfer of ink is not whether there is some sort of repulsion, but in which liquid cross-section splitting occurs. Splitting depends to a great extent on the cohesion of the liquid film. Offset inks have higher cohesion properties compared to water, which in turn means that splitting always takes place in the water film and not in the ink film.

Since it is always the water film that splits, any contact between printing ink and water has the effect that water remains on the ink film (and may consequently also penetrate the ink in an emulsified form). The spread coefficient determines whether the water spreads over the ink surface or not.

So that water is not repelled by the ink, the contact surface tension between ink and water must not be too high. Studies have shown that the contact surface tension primarily affects the water adsorbed on the ink surface, whereas the proportion of emulsified water depends on the cohesion of the ink.

As there is water on the ink film surface of the printing plate, the ink must also be able to displace the water from the image areas during inking (the water film reaches the image area first via the dampening unit). This does not cause problems, provided that the image area has already been inked.

Both the printing plate with its special properties and the ink and dampening solutions play a fundamental role. In *conventional offset* printing the interaction of surface tension between printing plate and ink is achieved by the addition of dampening solution. The same basic principle is applied in *waterless offset* printing, but with different surface/materials combinations. Consequently the surface of the waterless printing plate is made up of a highly ink-repellent silicone coating. Silicone oil is mixed into the printing ink, so that a separation layer forms when the ink comes into contact with the plate. Ink is only accepted on areas of the printing plate in which the silicone coating has been removed.

*Waterless offset printing* requires ink of comparatively high viscosity. Due to the milling operation in the inking unit, the inking form rollers get too hot (up to 50 °C); and the cooling effect offered by the dampening solution is also not present, which causes scumming effects. The temperature of the inking unit must therefore be stabilized. This may be done either by means of distributor rollers with water flowing through them or by an air current (very often in conjunction with plate cylinder cooling). The temperature of the inking form roller should not exceed 28–30 °C. Waterless offset printing is particularly suitable for fine

and very fine screens (low dot gain). The absence of dampening solution in this process simplifies the printing unit set-up, meaning that the desired production run quality is achieved more quickly. The absence of the cleaning effect provided by the dampening solution is a disadvantage and hickeys and paper dust deposit easily on the blanket and printing plate. The potential of waterless offset printing is dealt with in greater detail in [section 2.1.7](#).

### 2.1.1.2 Printing Plates, Printing Ink, Dampening Solution

#### Printing Plates

The plates used in offset printing are thin (up to about 0.3 mm), and easy to mount on the plate cylinder, and they mostly have a monometal (aluminum) or, less often, multimetal, plastic or paper construction. Aluminum has been gaining ground for a long time among the metal-based plates over zinc and steel. The necessary graining of the aluminum surface is done mechanically either by sand-blasting, ball graining, or by wet or dry brushing. Nowadays, practically all printing plates are grained in an electrolytic process (anodizing), that is, electrochemical graining with subsequent oxidation ([fig. 2.1-3](#)).

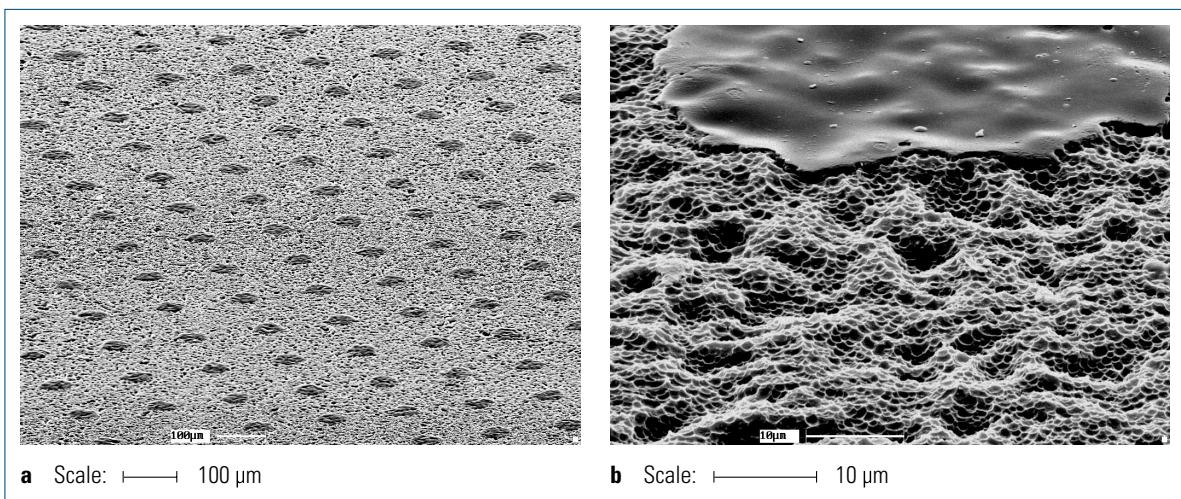
The imaging, ink-accepting coating (light-sensitive coating, thickness around 1  $\mu\text{m}$ ) is applied to the base

material. This material is usually a polymer, or copper in the case of multimetal plates (bimetal plates). Light-sensitive, diazo (photopolymer) pre-coated aluminum printing plates are now the predominant plates in printshops. The image transfer is produced via the different properties on the surface of such plates after they have been exposed and developed. The remains of the original light-sensitive coating or the light-sensitive coating changed by the effect of light are the ink-accepting (oleophilic) elements that create the image.

The thin coating of aluminum oxide created by the special treatment of the aluminum base material a particularly stable water-attracting (hydrophilic) surface with special retention properties. In processing a pre-coated offset printing plate the essential task lies in achieving surface differentiation using two basic steps, exposure and developing.

Chemical changes occur as a result of the penetration of photo-effective (actinic) light (light containing UV rays), causing the light-sensitive coating to react differently depending on its type and structure. There are two types of photochemical reactions when developing the printing plate:

- hardening of the light-sensitive layer by light (negative platemaking),
- decomposition of the light-sensitive layer by light (positive platemaking).



**Fig. 2.1-3** Aluminum printing plate with halftone dots.

**a** Magnified a hundred times;

**b** Magnified 2000 times

If the light-sensitive coating is hardened photochemically, it becomes insoluble for the developer in the exposed areas. If, on the other hand, the light-sensitive coating is decomposed photochemically, the developer removes the exposed light-sensitive coating from the base (e.g., aluminum). These two different platemaking processes (positive and negative platemaking) require different exposures to create images, that is, different types of films that are produced in advance (fig. 2.1-4).

With *positive platemaking* and conventional printing plate production, a positive film is used as the original, that is, the non-translucent, blackened sections of the film correspond to the ink-accepting surface elements on the plate. As illustrated in figure 2.1-4a, if light falls on the ink-free areas during exposure, the light-sensitive layer “decomposes,” which results in the non-image areas being uncovered (in this case aluminum) during the developing process. This process has the disadvantage that film edges and dust, that is, the darker areas on the film compared to the translucent image areas on the film copy, are sometimes reproduced on the printing plate as ink-accepting surface elements.

In the case of *negative platemaking* with “negative plates” a negative film is used as an original, that is, the ink-accepting image areas of the printing plate correspond to the translucent, light areas on the film. As shown in figure 2.1-4b, the light-sensitive coating is hardened on the printing plate by light, so that it stays

in place after the developing process, as opposed to the unexposed areas, which are removed.

The developed plates are then gummed up to protect the plate surface and preserve the plate. The finished printing plate will, of course, be identical in informational content regardless of whether positive or negative platemaking is used. Only the kinds of film used for production are different. Different characteristic curves between the tone value of the film and that of the plate must be taken into account in prepress.

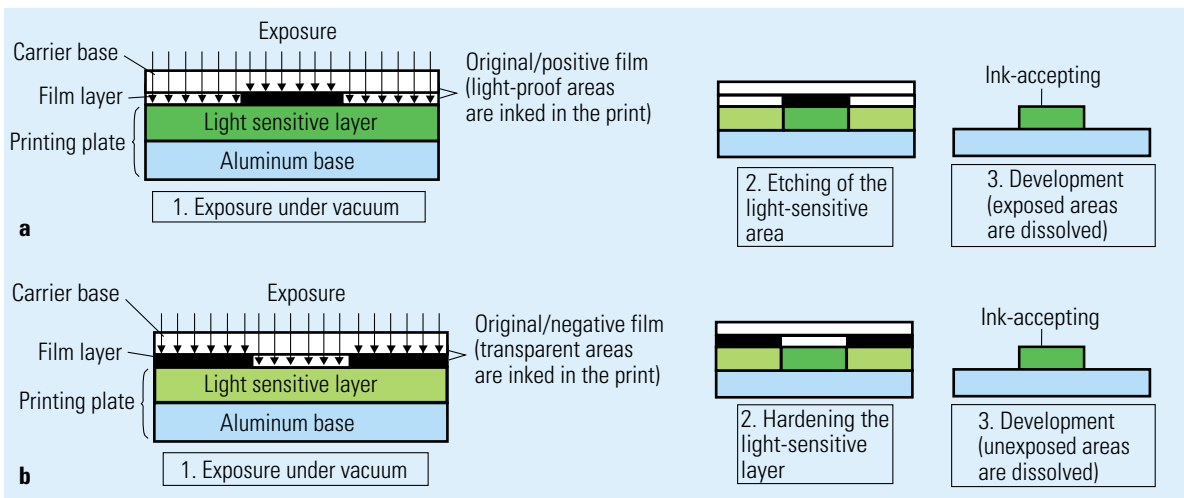
Whether to use positive or negative working plates is a fundamental decision to be made by the printshop. Many printing plates can be heat-treated (baked) after developing to increase their service life.

For smaller formats, single-color or multicolor jobs on medium-quality, *polyester-based plates* are for reasons of cost preferred over aluminum plates as their dimensional stability is lower.

For quality assurance and monitoring during platemaking, *control elements* are copied onto the plates. Standardized elements are available, for instance, in accordance with FOGRA’s standardization concept [2.1-1] with a wedge, such as the PMS or the UGRA offset test wedge (see sec. 3.1.7.2 and 4.3.7).

### Thermal Plates

Alongside conventional printing plate systems, thermal plates have been developed for digital imaging.



**Fig. 2.1-4** Platemaking.  
**a** Positive platemaking;  
**b** Negative platemaking



(These plates are described in [sec. 4.3.9](#) in connection with computer to plate technologies.) A polyester-based waterless offset plate is shown in [figure 2.1-5](#) as an example of a plate that is imaged by thermal ablation using laser light. Platemaking processes are described in detail in [section 4.3.9](#).

### Printing Ink

The ink used in offset printing is usually a highly viscous mixture having the basic components of ink pig-

ment, vehicle (binder), additives, and carrier substance (see also [sec. 1.5.2](#)).

*Ink pigments* can have either an organic or inorganic nature. The pigments determine the hue of the printing ink. They consist of solid, irregularly-shaped particles that are about 0.1–2  $\mu\text{m}$  in size.

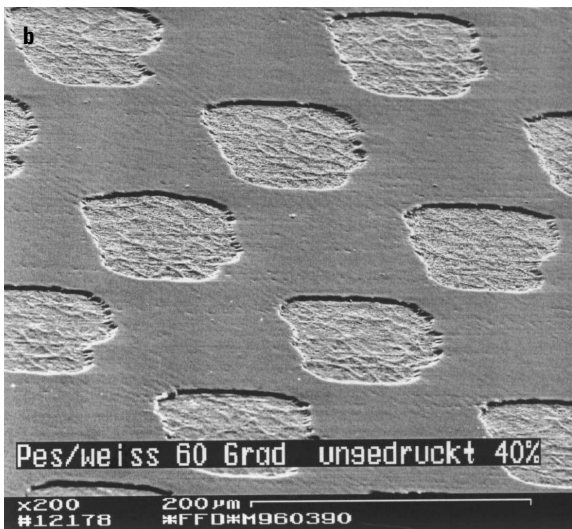
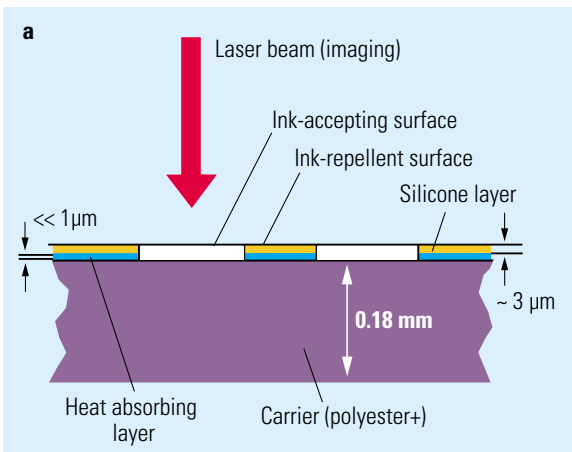
*Vehicles* (binders) are needed to bind the pigment, which is supplied in powder form, to the substrate. Vehicles also form a protective film around the pigments so that they are protected from mechanical abrasion. The composition of the vehicles depends on the printing technologies and substrate to be used. The vehicles used in the production of printing ink are also called “varnishes”. The real know-how of the printing ink manufacturer lies in the creation of the formula and the preparation and combination of the individual raw materials which make up the vehicle.

*Additives* can be mixed into the ink to achieve specific properties and to overcome specific printing problems. The additives and their specific uses are listed with examples in [table 2.1-1](#).

Mineral oils are used as *carrier substances* for offset inks. They fulfil the function of transporting the ink and are removed again in the drying process (evaporation, absorption). Conventional offset inks dry by absorption, evaporation and, depending on the type of ink, oxidation (see [secs. 1.7.1](#) and [1.7.2](#)). In addition to these most commonly used inks, there are inks that cure by radiation cross-linking (see [sec. 1.5.2.1](#) for UV and electron radiation). The structure of these inks is completely different than that of conventional inks. UV inks are available for both conventional (with dampening solution) and waterless offset printing.

### Dampening Solution

In the conventional offset printing process the dampening solution is used to separate the image and non-image areas, that is, to prevent the transfer of ink onto non-image areas of the printing plate. The dampening solution consists mainly of water. Experience has shown that in conventional offset printing the dampening solution should have a pH value between 4.8 and 5.5 and the water used in the dampening solution should have a hardness level of between 8 and 12° dH (1.43 and 2.14 mmol/liter; 1 mmol/litre = 100 mg  $\text{CaCO}_3$  per 1 liter water). Dampening solution usually contains plate preservative agents, wetting agent, isopropyl alcohol (IPA), buffer substances, and anti-microbe additives.



**Fig. 2.1-5**

Waterless offset plate with digital imaging by thermal ablation (Heidelberg/Presstek).

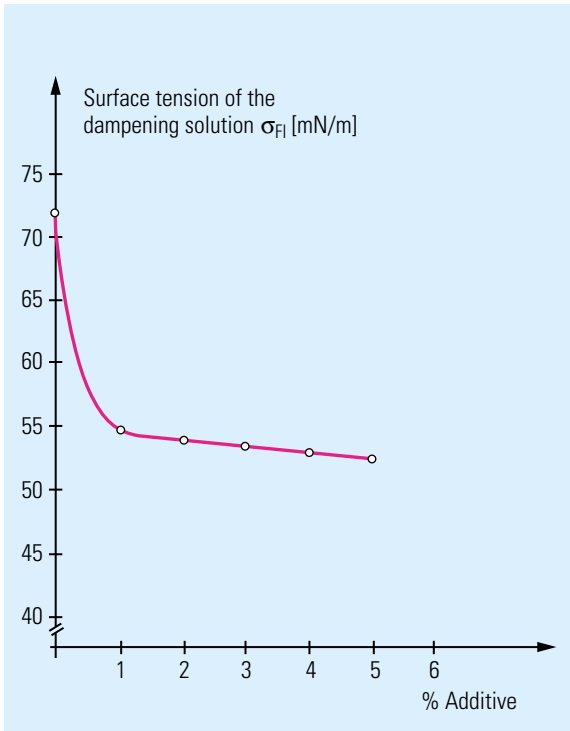
- a** Plate structure with imaging;
- b** SEM shot of the plate surface

Additives		Areas of use in the case of printing problems														
Types	Interaction and effect	Setting off	Chalking	Repelling	Drying	Piling	Hickeys/Dusting	Curling of the sheet ends	Picking	Increasing the abrasion resistance	Badly printing areas	Sticking in the ink fountain	Scumming	Unsatisfactory drying results	Ink too "short"	Ink too sticky
<b>Linseed oil varnish—highly viscous</b>	Thick varnish, tacky, increases viscosity.		•			•					•				•	
<b>Print oil</b>	Linseed oil and other drying oils. Weak varnish, reduces stickiness, makes the ink shorter and thinner. For oxidative drying.					•	•	•		•	•					•
<b>Diluent</b>	Low-viscosity mineral oils, partly combined with drying oils. Reduces tack, makes the ink shorter and thinner					•	•	•			•					•
<b>Print paste</b>	Waxes and similar substances which are dissolved in oils. Reduce the tackiness like liquid thinner, but without changing the viscosity.						•	•		•						•
<b>Print gel</b>	Jellied thinning agent: thickened mineral oils and other oils with different additives with thixotropic properties.						•	•		•						•
<b>Drying agent – Siccative (liquid) – Drying substance (solid)</b>	Metallic compounds dissolved in solvents or oils. – Cobalt = Surface dryer – Mangan = Internal dryer	•								•				•		
<b>Alumina hydrate</b>	Binder with transparent pigments. Increases tackiness, lightens up.		•	•		•							•		•	
<b>Abrasion resistant paste</b>	Wax with oxidative drying oils; makes the surfaces smoother to reduce friction.	•								•						
<b>Antistaling agent</b>	Spray. Highly volatile solvent.				•		•	•	•							•

**Table 2.1-1** Additives for inks and their areas of application

Gum arabic is used as plate preservative. Wetting agents and IPA are used to reduce surface tension. [Figure 2.1-6](#) shows the effect of reducing surface tension by a dampening solution additive. Admixed buffer agents are used to stabilize the pH value.

Antimicrobe additives are essential if the dampening solution is prepared for several offset printing presses in a central additive metering unit. Without these additives the pipes would become clogged due to the growth of algae. Alcohol-free dampening solutions contain alcohol substitutes such as glycol, instead of isopropyl alcohol.



**Fig. 2.1-6**  
Dependency of dampening solution's surface tension on the concentration of a dampening solution additive

### 2.1.1.3 Inking Unit, Dampening Unit, Printing Unit

#### Inking Units

During the printing process, a thin film of ink is transferred from the image areas of the plate to the substrate (ink film thickness on the substrate around  $1\ \mu\text{m}$ ). The inking unit's function is to provide a constant supply of fresh ink to the image areas on the plate to maintain a constant inking process. The amount of ink "used up" must be fed back to the system. There must be an equal balance between ink fed and ink dispensed in order to avoid variations in the ink density on the printed image.

Another important factor for the print quality is the uniformity of the ink film thickness on the image areas of the plate or the image areas of the substrate. (It is a postulate of offset printing that the film of ink should be of the same thickness across the entire printed sheet. Reproduction technology for the creation of color separations is based on this principle). Conse-

quently, the criteria determining quality are:

- temporary fluctuations of the average ink film thickness (quantity balances) and
- uniformity of the ink film thickness on the image areas of the plate or the printed areas of the substrate.

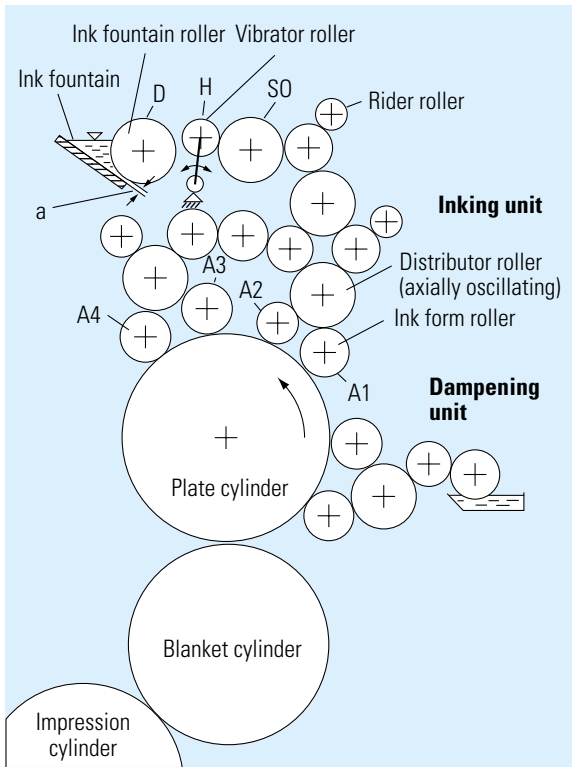
These parameters are dependent on the structural design of the inking unit. The quality of the microscopic full-tone density and the individual dots on the substrate depend primarily on the roughness of the substrate, the microgeometry of the plate and blanket, and the rheological properties of the ink.

In an inking unit like the one shown in figure 2.1-7, ink is fed intermittently via the oscillating vibrator roller H. The vibrator roller H receives a relatively thick ink stripe from the ink fountain roller and transfers part of this stripe to the first roller SO of the inking unit. The quantity of ink supplied via roller SO is determined by the ink zone aperture  $a$ , the rotary motion of the ink fountain roller (in most cases intermittently), the vibrator roller frequency, and the speed of the inking rollers. In addition to these *vibrator-type* inking systems there are also *continuous/film-type inking* systems (see fig. 2.1-15).

All the rollers of the inking unit (apart from rollers D and H) have the same circumferential speed as the plate and/or blanket cylinder. Apart from a negligible stretch slippage [2.1.-2] caused by deformation between stiff and the flexible rollers, the system works virtually without slippage. The applied ink stripe is split and transferred several times. The quantity of ink in the inking unit depends on the number of inking rollers and/or the size of their surfaces. With an optimal design the inking form rollers A1–A4 will produce a relatively constant ink film on the image areas of the plate cylinder rather independent of the printed image, that is, after the last ink form roller A4, the oleophilic areas are inked with a practically even ink film.

Part of the ink film is applied to the substrate in the printing zone (between blanket and impression cylinder). A distinctive feature of offset printing plates is the fact that the printing and non-printing areas are on one level. To separate these areas a very thin (approximately  $2\ \mu\text{m}$ ) dampening solution film is applied to the plate by the dampening unit. Part of the dampening solution is printed, part emulsifies together with the ink, and part evaporates.

The mass balance of the quantity of ink "printed" and the quantity of dampening solution consumed must correspond to the respective quantities fed. If



**Fig. 2.1-7**

Diagram of an inking unit and dampening unit of an offset printing press

this is not the case, temporary variations in average ink-film thickness arise.

Intermittent ink supply (vibrator and ink fountain roller) and the intermittent transfer of ink onto the substrate (non-printing and printing elements on the plate) imply that in reality there is no such thing as a precisely continuous, constant ink flow. The ink-splitting processes between the individual contact sections (nips) and the splitting in the inking unit need to be taken into consideration.

Figure 2.1-8 shows a simplified model of an inking process with an ink form roller to illustrate the creation of retroactive disruptive effects [2.1-3] during the application of ink (fig. 2.1-8). The layer of dampening solution is not to be taken into account for this model. Before the inking process starts there is a film of ink with thickness  $S_1$  on the ink form roller. The printing elements on the plate carry a residual ink film with thickness  $S_2$ . This means that after inking, the printing

element on the plate has the new ink film  $S_4$  and at the relevant location on the ink form roller the ink film of thickness  $S_3$  remains. Using the ink-splitting factor  $\alpha$  (given that the ink films are closed, and not as shown in fig. 2.1-8 in segments) the ink film thicknesses of  $S_3$  and  $S_4$  turn out to be

$$S_4 = \alpha (S_1 + S_2)$$

$$S_3 = (1 - \alpha) (S_1 + S_2).$$

Figure 2.1-8a shows that directly before and after the point having the thickness  $S_3$ , the ink form roller has a film thickness  $S_1$ . This means there is an irregularity in the film thickness with the difference  $\Delta s = S_1 - S_3$ . This difference is reduced by the turning distributor roller (see fig. 2.1-7) and by feeding new ink via the inking unit although it is not completely eliminated. This difference then becomes apparent in the printed areas on the substrate so that the ink film is not perfectly even over the printing elements but there is a more or less distinct relief in the film that could impair the printing quality to a greater or lesser extent (ghosting, see also fig. 2.1-17), depending on the inking unit design.

Figure 2.1-8b shows the basic ink-splitting processes and film thickness ratios from plate cylinder up to the printed sheet. This representation was based on an ideally constant ink-splitting factor  $\alpha = 0.5$  and a constant film thickness on the plate of  $S_4$ .

There are two approaches to developing/designing offset inking units:

- the experimental approach and
- the theoretical or computational approach (further information on inking unit design can be found in sec. 13.1.3.2).

The experimental approach requires the construction of several offset printing unit prototypes or one very variable prototype used for printing tests. So that utilizable results can be achieved, the technical printing parameters must be kept constant.

The theoretical approach simulates the transportation of the ink and dampening solution in the inking unit using computers and a corresponding computer program.

The ink-transfer functions constitute the basic elements of a theoretical model for computing the ink and dampening solution transport. Distinction has to be made between two types of ink transfer in an offset inking unit. In the actual printing process, ink and damp-



smaller they are, the better the inking quality of the inking unit. This is defined by the degree of irregularity  $\eta$ .

$$\eta = \frac{S_{\max} - S_{\min}}{S_{\text{average}}} \cdot 100\%$$

$S_{\max}$	the maximum ink film thickness on the plate printing elements,
$S_{\min}$	the minimum ink film thickness on the plate printing elements,
$S_{\text{average}}$	the arithmetic average of the ink film thickness of all plate printing elements.

Theoretical and practical experiments [2.1.-5] have indicated that the inking behavior of front-heavy inking units is clearly better than that of back-heavy systems. Therefore modern offset inking units in web-fed and sheet-fed presses are usually designed as front-heavy systems.

Another option for increasing inking-up quality is to install additional rider rollers, which smooth the ink film on the rollers in the main ink flow (figs. 2.1-7 and 2.1-9). Various inking unit designs are shown in figure 2.1-10.

These roller-type inking units consist of a number of alternating stiff and flexible coated rollers. The stiff

rollers (hard surface) generally perform a reciprocating movement in a transverse direction (they are also referred to as “distributor rollers”) to smoothen out the ink profile on the roller surface and the scores/lines in the ink which appear in the travel direction of the sheets.

Newspaper presses, which have lower print quality demands than commercial presses, also use ink-zone-free short inking units or “*anilox inking units*” (fig. 2.1-11, see also sec. 2.1.3.5). These inking units have a simpler design than conventional inking units and offer the great advantage that the inking unit is in stable equilibrium after only a few revolutions due to the low ink storage capacity. The main disadvantage of these systems is that they require inks with lower viscosity than conventional inking units, which leads to a high dot gain during printing.

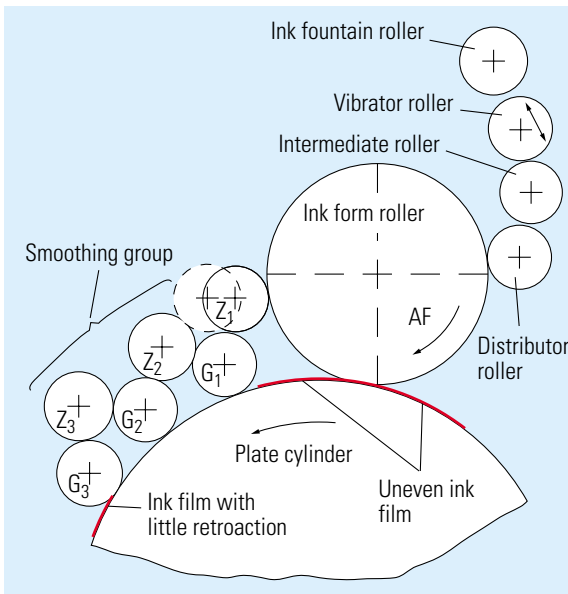
Like a gravure cylinder, the anilox roller (fig. 2.1-11) has cells. These cells all have the same filling volume. Wear is an important consideration as the excess ink is squeezed off the roller, although adequate service life is ensured with the materials used nowadays (ceramic screen roller, blade made from high-alloy material).

Dampening solution metering is particularly critical with short inking units, the dampening solution that is not taken up by the printing plate cannot evaporate on its short path to the ink fountain, which means it collects in the ink fountain. The main advantage of short inking units is the ink-zone-free ink feed, especially with “*anilox inking units*”.

Conventional roller-type inking units need special ink feed systems with the option of metering the ink in the *ink zones*. Examples include fountain roller blades and fountain roller, ink zone systems.

As illustrated in figure 2.1-12, a flexible ink blade can be adjusted at varying distances to the ink fountain using ink screws to adjust the amount of ink taken out of the ink fountain. This ink blade system is not without side effects (cross talking). The ink blade can be designed to rest as a beam on  $n$  supports ( $n$  the number of ink screws). Adjusting a single ink screw may affect not only the zones right next to it, but the entire system. Therefore printing press manufacturers have developed various solutions for ink zone systems free from side effects.

The following is a short description of the ink zone system from Heidelberg Druckmaschinen AG (fig. 2.1-13). The ink film defined in thickness is created by the interaction of ink fountain roller and adjusting cylinder. The adjusting cylinder has an eccentric section which ends just in front of the cylinder so that rings are produced that rest on the fountain roller. As



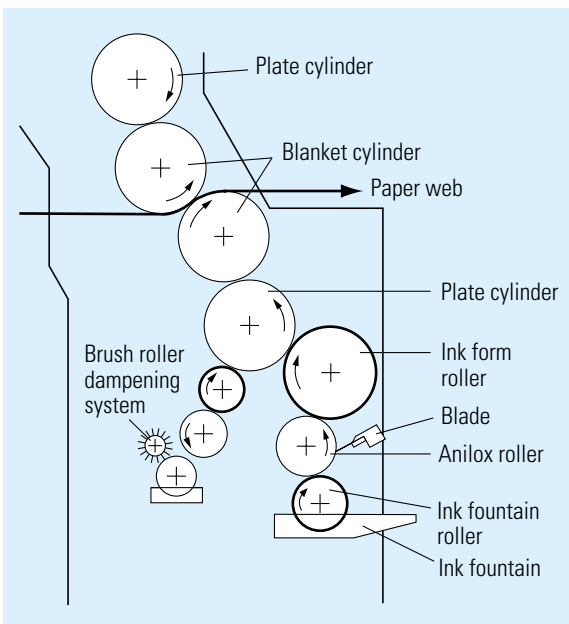
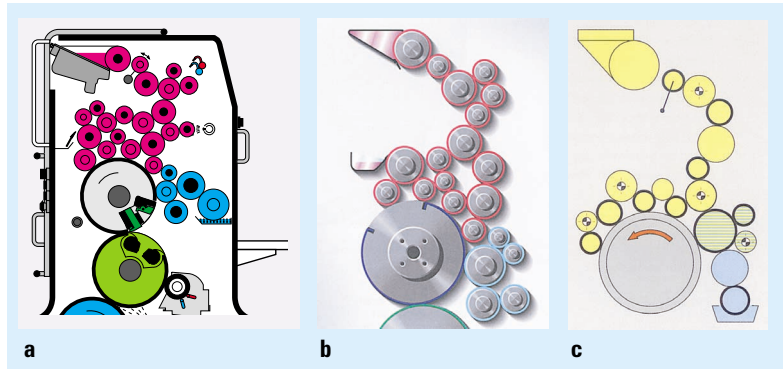
**Fig. 2.1-9**

Inking unit with film-thickness smoothing system on the plate cylinder

**Fig. 2.1-10**

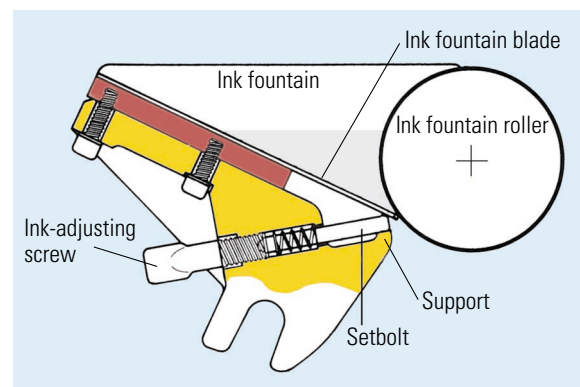
Inking unit designs for offset printing units.

- a** Speedmaster 102 (Heidelberg);
- b** Roland 700 (MAN Roland);
- c** Rapida 104 (KBA)

**Fig. 2.1-11**

Example of a "short inking unit" in an offset printing unit for newspaper printing

shown in [figure 2.1-13b](#), ink-free areas are produced that on the fountain roller as a result of supporting the adjusting eccentrics. This is compensated for by the axially oscillating distributor rollers in the inking unit so that the plate is covered in an evenly closed ink film in line with the print image. A cover foil is inserted between the ink fountain roller and the adjusting cylinders, which also facilitates cleaning the ink fountain. Due to its structural design the system automatically compensates for both inaccuracy in the concentric

**Fig. 2.1-12**

Ink fountain with continuous ink duct blade and ink fountain screws

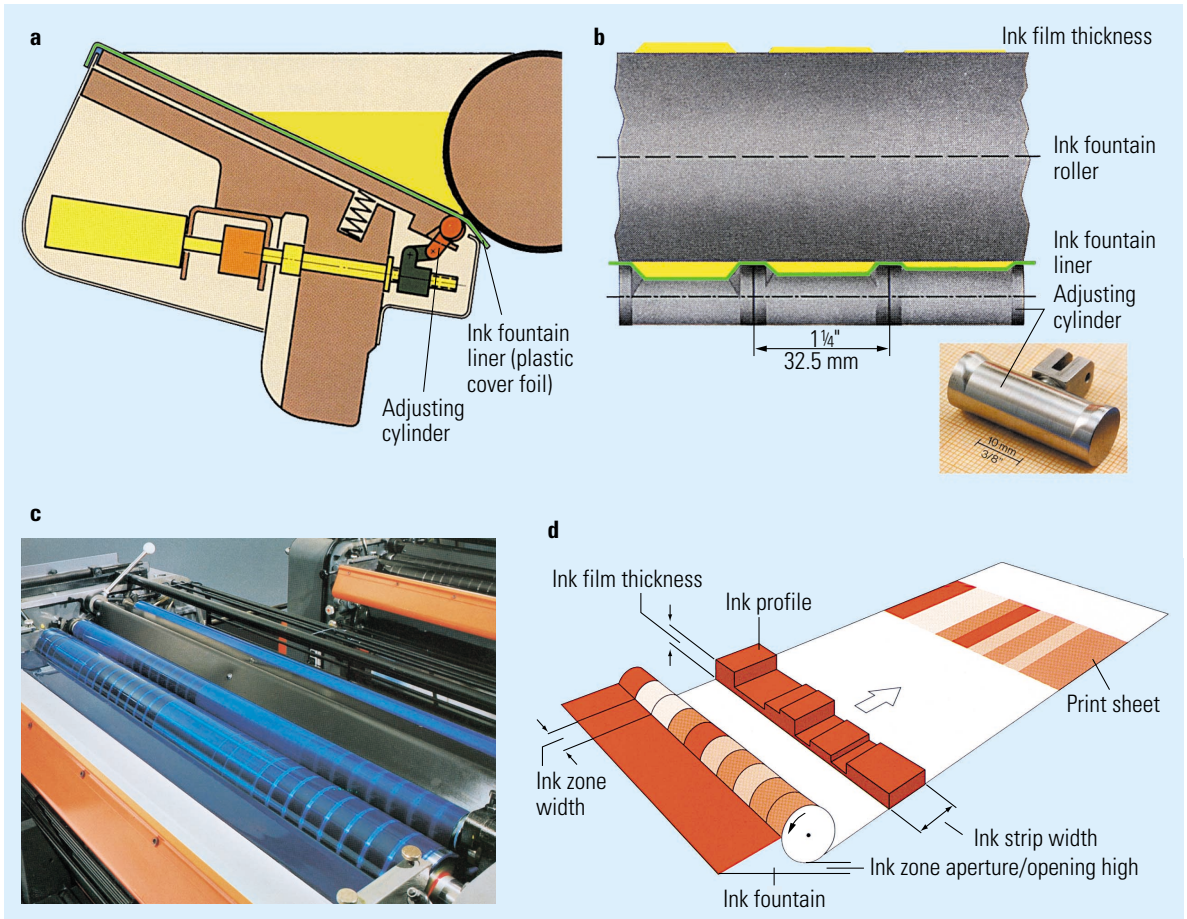
running of the fountain roller and expansion due to heat and, as such, can be described as a self-stabilizing design.

Other ink zone systems with no side effects have also been developed, such as ink slides or slotted ink duct blade and doctor blade systems ([fig. 2.1-14](#)).

Conventional inking units (as shown in [fig. 2.1-7](#)) therefore require adjustable ink feed systems since ink consumption varies across the width of the press in accordance with the image. The ink zone elements and/or the ink fountain blade have to be adjusted accordingly (see also [fig. 2.1-13](#)).

### Dampening Units

Conventional offset printing requires a dampening system to supply a very thin film of dampening solution (approx. 2  $\mu\text{m}$ ) to the non-printing elements of the printing plate. Since part of the dampening solution is printed via the ink, plate, and blanket and another part



**Fig. 2.1-13** CPC ink fountain with zonal ink feed adjustment free from side effects.

- a** Ink fountain;
- b** Adjustment eccentric (adjusting cylinder);
- c** Ink fountain in the printing unit;
- d** Diagram of zonal ink feeding (Heidelberg)

evaporates, it is necessary to have a constant supply of dampening solution. Continuous/film-type dampening units are shown in [figures 2.1-7](#) and [2.1-10](#), and a contact-free brush-type dampening system is shown in [figure 2.1-11](#). Other dampening system designs are shown in [figure 2.1-15](#).

Dampening units have developed from the “dampening roller” used to dampen the lithographic stone. Vibrator-type dampening systems and continuous-flow dampening systems are systems with contact between the dampening solution pan, the dampening vibrator, and the printing plate. The disadvantage of these dampening systems lies in the fact that substances

(e.g., particles of ink, paper dust) can get from the printing plate into the dampening solution pan and can lead to contamination. This problem does not occur in dampening systems that are contact-free or where there is no feedback from plate or ink flow. The amount of dampening solution has to be metered very accurately, as excess dampening solution cannot flow back from the printing plate into the dampening system with these systems. The systems are known as “brush-type and centrifugal dampening systems” ([fig. 2.1-15d](#) and [e](#)).

*Vibrator-type dampening systems* ([fig. 2.1-15a](#)) often have dampening rollers covered with absorbent mate-



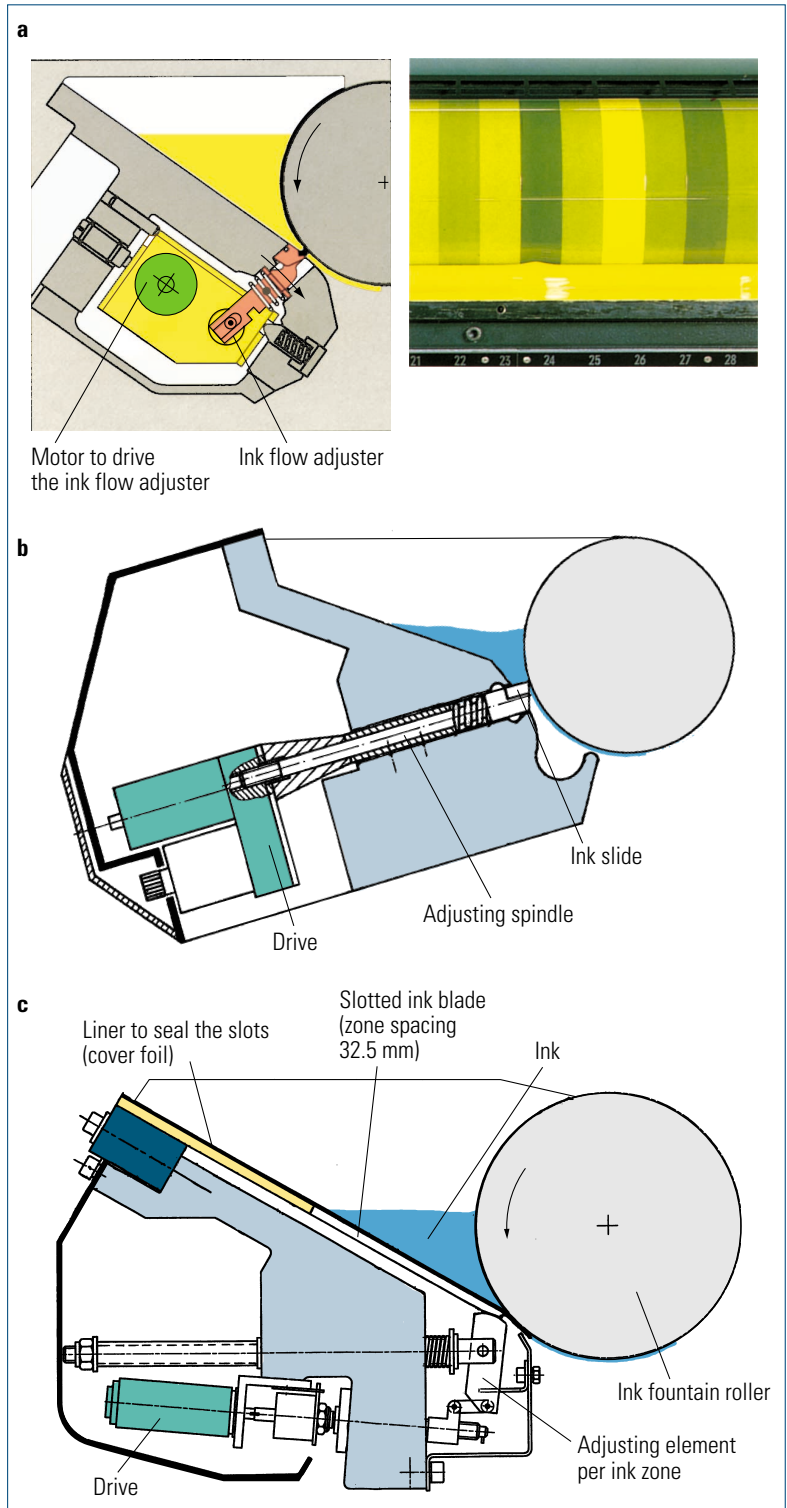
**Fig. 2.1-14**

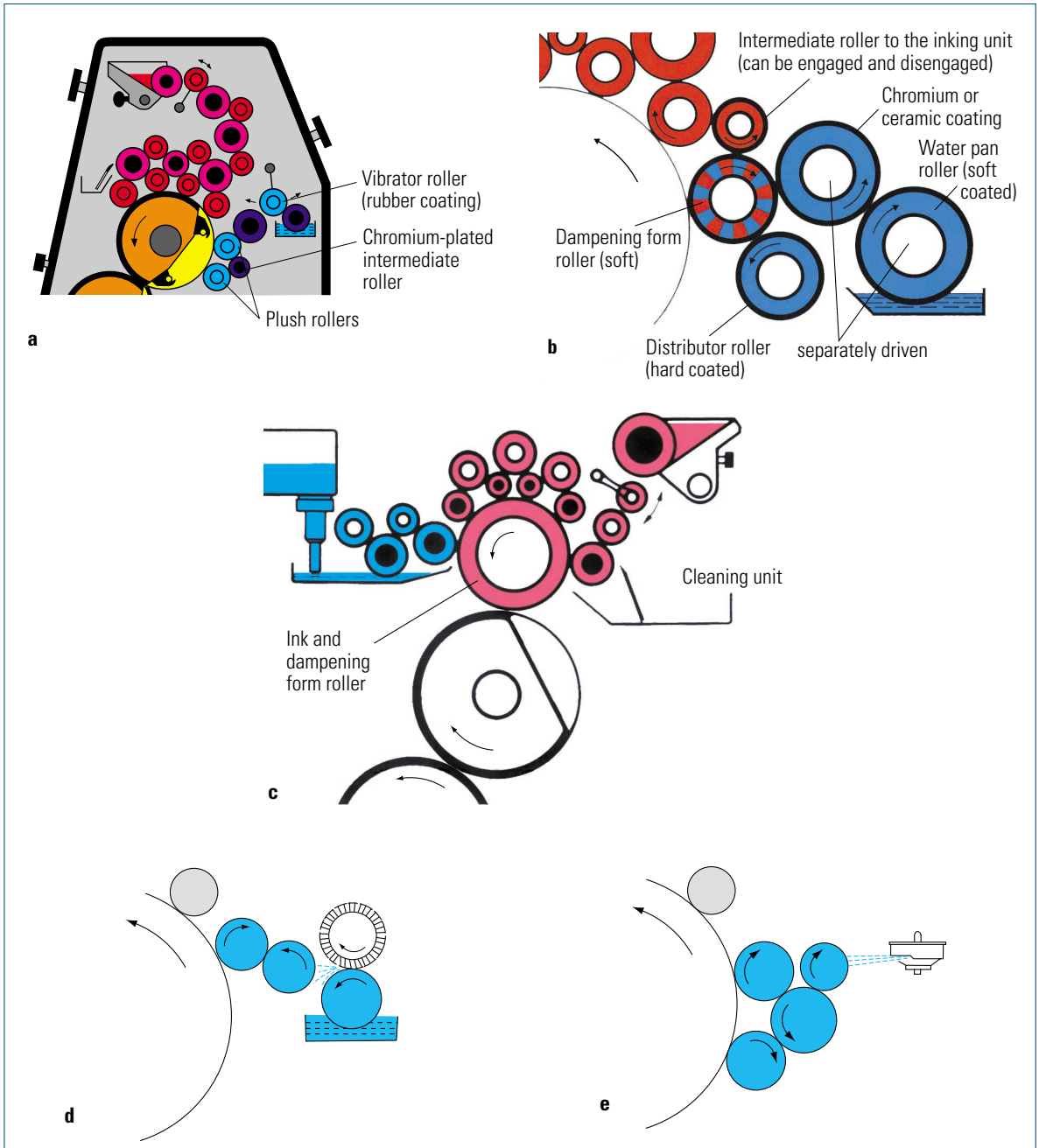
Ink fountain systems with zonal adjustment (free from side effects).

**a** Metering lever system (Model: Colortronic, KBA);

**b** Ink slide system (Model: RCI/CCI, MAN Roland);

**c** Ink knife system (Model: CPC/Web, Heidelberg)





**Fig. 2.1-15** Dampening system designs.

- a** Vibrator-type dampening system;
- b** Continuous-type dampening system;
- c** Indirect dampening solution application through the ink roller;
- d** Brush-type dampening system;
- e** Centrifugal dampening system

rials (e.g., molleton, plush). The inertia of these systems with respect to necessary changes with the amount of dampening solution to be fed is very great because the cover absorbs a great amount of dampening solution. The fabric covering also has other disadvantages with regard to the printing process:

- high maintenance,
- high paper waste rate because the required ink/dampening solution balance is reached very slowly,
- frequent malfunctions due to coverings becoming fluffy (mainly with new covers),
- often uneven distribution of the dampening solution,
- high risk of excessive supply of dampening solution.

*Continuous-type dampening systems* (fig. 2.1-15b) work without ductor/vibrator roller and fabric-coverings yet do usually need alcohol additives or special dampening solution additives. Dampening systems acting directly on the plate use dampening form rollers to transfer the dampening solution onto the plate.

In the case of *indirect systems* the dampening solution is fed to an ink form roller which then transfers ink and dampening solution to the plate in dispersed form (dampening solution also in the form of “surface water”), (fig. 2.1-15c).

*Contact-free dampening systems* are known as *centrifugal, turbo* or *brush-type systems* (figs. 2.1-15d and e). Here, dampening solution is catapulted onto the printing plate as finely dispersed droplets. Adequate surface tension ratios must then ensure a rapid spreading of the droplets. Droplets have essential disadvantages compared to the continuous-type application and it is therefore continuous-type dampening systems that prevail in the commercial printing sector. The main advantage of catapult (centrifugal) dampening systems is that the quantity of dampening solution can be metered in axial direction of the roller/plate (this is an advantage since different quantities of ink and dampening solution are needed to achieve an even emulsion throughout the ink zones).

Printing inks absorb dampening solution to a certain extent. Printers refer to this as an “emulsion”. In physical/chemical terms it is an ink/water dispersion. The dampening solution is contained in the ink in the form of droplets and some of it also sits on top of the ink film.

If the dampening solution droplets fall below a certain size, the offset printing process immediately breaks down, that is, the transfer of ink onto the plate is no longer even or in accordance with the image. The tiny droplets of dampening solution mean that separation of the printing and non-printing plate elements is no longer possible. Scumming is the result, that is, the non-printing areas on the plate also print.

As with inking units, there are dampening system designs that allow the path and the distribution of the dampening solution application to be changed. This can be achieved using intermediate rollers that can be engaged and disengaged from the inking unit (fig. 2.1-15b). The quantity transferred can be changed and the cleaning effects achieved at the printing plates by using variable drive ratios of the dampening rollers (slippage).

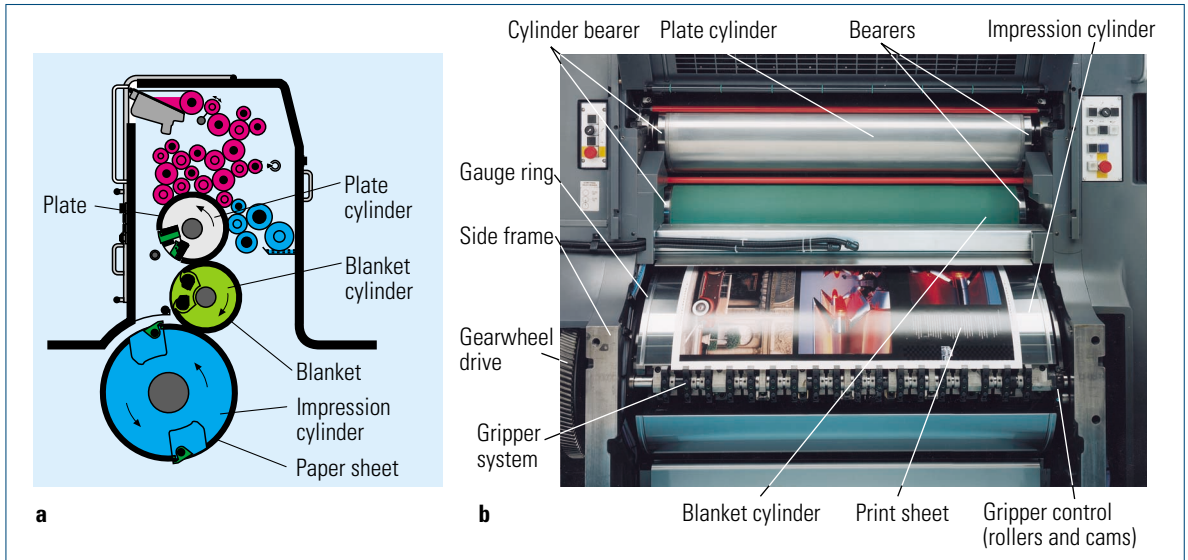
### Printing Unit

The structure and action of an offset printing unit is described below using the example of a typical sheet-fed printing press in unit-design (fig. 2.1-16). Presented in a simplified form, a printing unit of this type consists of inking and dampening units (already described), the plate cylinder with the printing plate, the blanket cylinder with the blanket fixed to it, and the impression cylinder. The plate cylinder with the inked printing plate rolls over the circumference of the blanket cylinder. The blanket cylinder, in turn, rolls over the circumference of the impression cylinder, on which the sheet of paper is held by grippers. The contact line between the blanket cylinder and the impression cylinder is called the printing nip.

The printing plate – an up to 0.3 mm thick sheet of metal or a foil – carries the image elements of the respective color separation. The blanket is an approximately 2 mm-thick, exchangeable cylinder cover made from flexible material and layers of fabric.

As can be seen in figure 2.1-16a, the plate cylinder’s circumference is interrupted by an axial recess, the cylinder gap. This recess holds the plate clamping mechanism. The blanket cylinder, likewise, has a gap to hold the blanket clamping mechanism, and the impression cylinder has a gap to accommodate the gripper system for paper transportation.

To ensure perfect transfer of the print image from plate to paper, all three cylinders must have the same circumferential speed at the contact line/printing nip. Due to the recesses in the cylinder’s circumferences, the relative rolling motion necessary for continuous pro-



**Fig. 2.1-16** Offset printing unit.

- a** Cylinder configuration;  
**b** Bearers, gearwheel drive and gripper control in sheet offset (Heidelberg)

duction cannot be achieved simply by friction between the cylinder surfaces. Along with the frictional connection via the cylinder surfaces, the cylinders are also connected via a gear train for this reason.

The printing unit is driven by the impression cylinder via a gear train. The printing unit in turn transmits the necessary drive power for the inking unit. Printing problems arising from the gear train (the unwelcome “gear marks” in particular) are avoided by the narrow tolerances specified for the design of gearwheels and thanks to tried and tested production technology and quality control.

An important aspect of gearwheel design is to provide for an adjustable spacing of cylinders, so that certain operating conditions can be met (engaging and disengaging of the cylinders). When setting the paper thickness, the variable spacing between blanket and impression cylinder shafts must be given particular consideration when going to impression on. For operational reasons changes in shaft spacing are achieved by using helical toothing with an appropriate tooth profile. This type of toothing is, to a large extent, insensitive to changes in the shaft spacing.

It must be ensured that even at the smallest shaft distance there is enough backlash and that at the largest shaft distance the teeth still mesh perfectly. For this rea-

son, “full-depth teeth” are used for printing presses. Moreover, the synchronized operation of the cylinders is optimized by the helical gearing. This increases the contact ratio of the gears.

For the proper transfer of ink between plate and blanket and between blanket and paper, a sufficiently high contact pressure between the cylinders as well as the same circumferential speed of the cylinders are necessary. To adjust the contact pressure between plate cylinder and blanket cylinder, which move towards each other at a fixed axial clearance, the plate or the blankets are underlaid, a process which results in a 0.05–0.15 mm radial deformation of the blanket. The printing pressure between the blanket and the impression cylinder is set according to the nature of the substrate.

The gearwheel-drives produce slippage between the surfaces. The slippage means that, in addition to the radial deformation of the blanket in the contact zone, the cylinders also undergo tangential deformation. The forces cause the deformation of the blanket to die down abruptly during the rotation of the cylinders at the start of the gap and are just as abruptly built up again when the cylinders come into contact again. This fluctuation of the contact pressure between zero and the maximum value is also referred to as “cylinder gap shock.” It caus-

es vibrations in the printing unit which impair the printing result.

Bearer rings, also called “cylinder bearers”, made from hardened steel with high rolling strength are inserted on the sides of the plate and blanket cylinders to minimize the effect of this vibration. They are of approximately the same diameters as the working pitch diameters of the gears and roll upon one another at high initial tension. The initial tension of cylinder bearers is approximately 15000 N on presses for the 70 cm × 100 cm (28" × 40") printing format. The basic task of the cylinder bearers is to prevent the rotational vibrations that would normally be generated between the cylinder and gears. In addition, the rigidity of the cylinder couples is increased by the cylinder bearers. This shifts the resonant frequency into non-critical ranges and reduces bending vibrations, which are caused when the cylinders roll over the gaps. Furthermore, by choosing varying cylinder bearer diameters, which are slightly smaller on the plate cylinder than on the blanket cylinder, it is possible to create initial tension in travel direction between cylinder bearers and gears. This ensures an optimal groove angle with well defined flank contact of the gears even if there is a long torque impact during over-running of the gaps.

As previously stated, for the proper interaction of plate, blanket and impression cylinders it is essential that they be connected to each other so that no relative motion takes place in a circumferential or radial direction, that is, as little vibration as possible is produced. Thus the cylinders have to be fixed to each other with a minimum of oscillation. Therefore, the structural design of cylinder bearing and printing unit frames takes on considerable importance. For all three cylinders the bearing assemblies must be dimensioned for high forces. Moreover, to ensure an accurate ink transfer, the cylinders must be very rigid and rotate with zero backlash.

Due to the diagonal register adjustment (see [sec. 2.1.2.3](#)), the plate cylinder must also allow for an angular adjustability of the bearings and the blanket cylinder bearing must allow for complex switching motions. Due to the diverse requirements, printing presses are practically always equipped with almost zero-backlash needle bearings or pretensioned tapered roller bearings. They are supplied by roller bearing manufacturers with factory set pre-tension.

As can be seen in [figure 2.1-16b](#), the cylinders with their bearings are supported between two vertical side frames which are mainly made from high-quality casting material. Since the exact parallel alignment of

cylinders is of vital importance, the side frames are machined in pairs to make the holes which are to take up the cylinder bearings. To give the printing unit the necessary rigidity against vibration and distortion, the side walls in the lower area are screwed to a rigid, box-type base frame. In some designs the base frame also serves as a machine foundation. Cross bars are used in addition to reinforce the printing unit frame as well as the base frame.

Alongside supporting the cylinders, the press frame has the task of absorbing the forces and torque that occur during operation of the printing unit. The gripper systems, for example, are supported by rollers and cam followers revolving along with the cylinder on gripper opening cams. These are firmly connected to the press frame and control the opening and closing of the grippers depending on the printing unit's angle of rotation.

There are many components that move against one another in a printing unit. In the interests of continuous functional performance and the service life of these components, adequate lubrication is essential. The bearings and gears, in particular, place high demands on the lubricant. From a technical point of view, oil lubrication is the most suitable. However, leakage can be a problem. Therefore, for presses of small- to medium-sized formats liquid grease is also used. When selecting lubricants, factors such as their compatibility with different solvents, their effect on non-ferrous metals and plastics, and their durability must be considered. When using liquid grease in central lubrication systems, the flowing qualities also play an important role.

#### 2.1.1.4 Print Quality

Quality control and corresponding measurement technique are dealt with in detail in [sections 1.4, 2.1.4, and 3.2.2](#). Only an overview of the parameters that define quality will be given at this point. The quality characteristics of printed products are described in [\[2.1-6\]](#). One or another quality criterion (quality characteristic) may become more important, depending on the print job and the subject. The most important *quality criteria* are:

##### Evenness of the Optical Density of Halftone Areas

If, for example, a halftone area in a printed image has a constant tonal value, small differences in the order of  $\Delta D = 0.02$  can be perceived by the human eye (see also [sec. 1.4.1](#)). Fluctuations in the print are noticed in the form of cloud formation or streaks. If the optical density fluctuates from copy to copy these fluctuations are immediately apparent when comparing the prints.

### Evenness of the Optical Density of Solid Areas

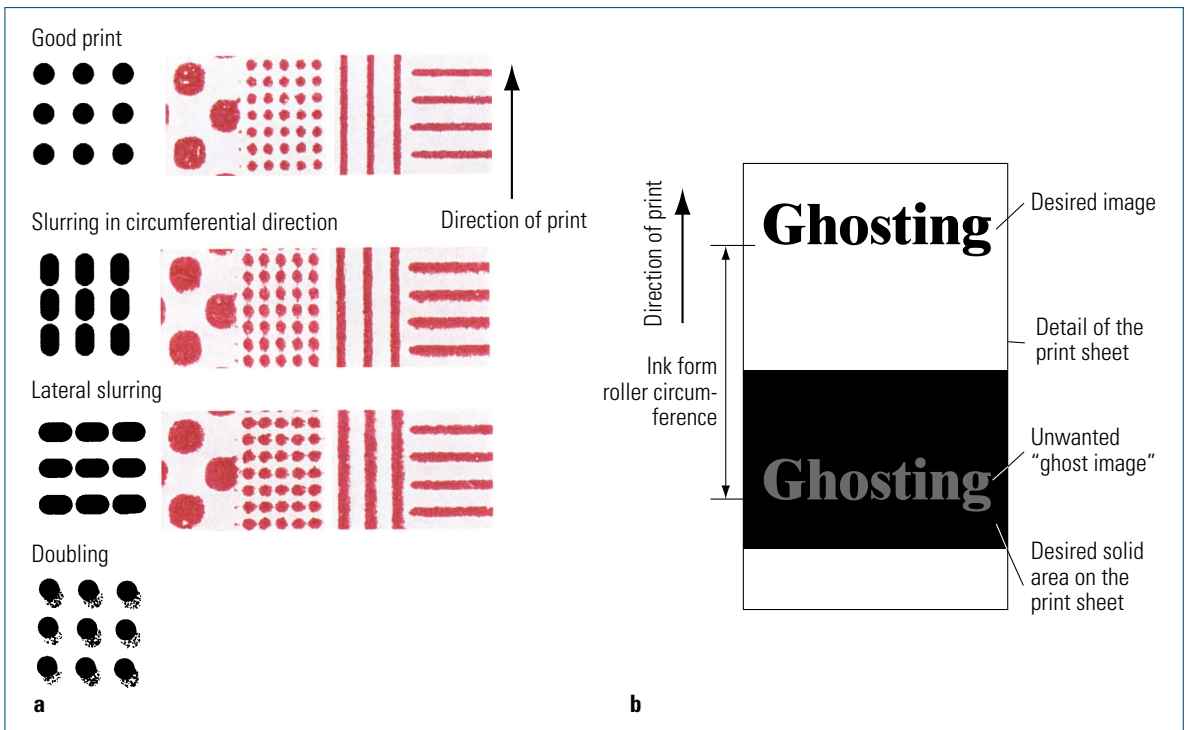
Fluctuations within a printed product or even from copy to copy can be also perceived easily by the human eye in this case.

### Halftone Value Transfer

Considerable differences in tone value can occur during both platemaking and printing and have a detrimental effect on print quality. However, constant halftone value transfer can be achieved in platemaking and in printing by standardization of the offset process [2.1.-1]. The blanket and the press setting exert the greatest influence on the transfer of tone values during printing. A change in the contact pressure acting between the plate and the blanket cylinder causes considerable changes in the transfer of tone values. A change in the contact pressure acting between the blanket and the impression cylinder tends to produce only small tone value deviations.

Deformations of the halftone dots in the halftone image can very easily lead to dot gain and color shifting. Slurring and doubling are the two most important influential factors when printing (fig. 2.1-17a).

In the case of *slurring*, the print ink is squeezed over the edge of the halftone dots. This is caused by relative movements between the surfaces of the printing plate and the blanket cylinder or between the blanket cylinder and the substrate, meaning that the surfaces then no longer fit precisely on top of one another. Slurring in the direction of print is known as circumferential slurring and slurring at right angles to this as lateral slurring. It is usually caused by the pressure between two adjacent cylinders being too great. Since the blanket has hardly any area to give way in the lateral direction, the deformation occurs predominantly in the direction of print. In this case, a round dot is deformed to become an ellipse. An insufficiently tensioned blanket or excessive inking can often also be the cause. Slur-



**Fig. 2.1-17** Quality attributes of printing.

**a** Dot deformation caused by slurring and doubling;

**b** Ghosting effect in the print image caused by the feedback of the ink on the plate to the ink form roller for the image to be printed and the subsequent inking of a further ink-accepting area on the printing plate

ring can also occur in the lateral direction. Directional errors can be clearly seen on color control strips with line fields (fig. 2.1-17a). Lines which are at right angles to the direction of print become wider due to slurring in a circumferential direction; the halftone becomes darker while the lines remain unchanged in the direction of print.

*Doubling* is when a halftone dot increases in size and the desired dot of the print image has a double (or multiple), shadow-like contour. This lightly offset color impression increases the halftone values, that is, leads to dot gain. Doubling is caused by register deviations during the printing process (caused by press vibrations and/or paper deformation, feeding variations). In multicolor presses the print sheet with the fresh ink, for instance, from the first printing unit, is pressed against the blanket cylinder of the subsequent second printing unit. Due to ink splitting an impression of the halftone structure is produced on this blanket which is then printed again on the subsequent sheet (or section on a web-fed printing press). This means that the image must be printed precisely onto the freshly printed image as the image elements are otherwise enlarged by doubling. The film thickness of this enlarged area is less than the actual print, in accordance with the ink film on the blanket of the subsequent unit. As little as 10 µm misalignment leads to tonal shifts.

### Ghosting

Ghosting is when image elements overlap onto subsequent image areas in the direction of print (fig. 2.1-17b). The inking rollers are generally smaller than the plate cylinder in a roller inking unit. After inking the plate, an ink profile remains on the inking roller due to the ink splitting and can appear in the print image as a “ghost image” after one roller revolution. Several ink form rollers of various diameters (on sheet-fed offset printing presses normally four form rollers) and a correspondingly dimensioned inking unit regarding the number of rollers and the points of contact as well as the effect of the lateral distribution, usually ensure that the ink film is smoothed out sufficiently on the printing plate. However, with an unfavorable color combination on the printing plate with regard to the geometry of the inking unit, visible ghosting effects can occur.

### Mottling

Mottling is the spotty and cloudy appearance of the ink on the substrate. An uneven absorption of the printing inks by the substrate between the printing units of a

multicolor press leads to uneven re-splitting on the subsequent blankets.

Unevenness in absorption causes uneven ink acceptance, which becomes visible, particularly in overprinting with potentially increased severity of the mottling effects. The faster and more evenly the ink is absorbed the better and more even the ink acceptance of the subsequent ink. The mottling effect can be counteracted, in particular by altering the absorption characteristics of the inks, by changing the sequence in which the inks are printed, or by using a different kind of paper. Mottling is influenced significantly by the characteristics of the paper with regard to the homogeneity of its structure and its coating.

### Trapping

Trapping is the acceptance behavior of the ink in wet-on-wet overprinting of several inks. The ink splitting is mainly dependent on the rheological properties (e.g., tack) of the inks. So that the ink adheres well to the already printed inks, the subsequent ink must have a lower tack.

### Absolute Value of Optical Density and Color Location

The absolute value of the optical density together with the colorimetric specifications of the color used also determines the color location. Colorimetry based on spectral values is primarily used for multicolor prints where separated colors are overprinted.

The optical density or color location value must be kept within the tolerance limits by means of suitable measuring and control systems. This applies both for halftone areas and solid areas. While a densitometer reading will often suffice for measurements during production, a spectrophotometer reading is necessary for efficient makeready and color analysis.

### Register

The register (the accurate overprinting of the individual color separations) has a crucial influence on print quality. The sharpness and cleanness of a four-color print is greatly affected by the accuracy of the color register.

Register refers to the accurate positioning of the printed image on the substrate in relation to the sheet edges or the web cut-off length; mostly we also talk about colour register with our printing of color separations.

### Gloss

The gloss of the printed image, and above all the evenness of the gloss, has a subjective effect on the print quality, although the legibility of extremely glossy

printed products decreases. Visually, a high gloss is often associated with high print quality.

### Type of Screening

The finer the screen, the higher the resolution achievable for the print, but also the greater the dot gain. To avoid moiré and rosette effects in multicolor printing, non-periodic screening has often been used. With these screens it is also possible to reproduce fine details of the original, and register fluctuations have a less pronounced effect on color fluctuations (see also [sec. 1.4.3](#)). Further improvements to the print can be achieved with hybrid screens (combination of period and non-periodic screening technologies).

### Whiteness and Uniformity of Substrate's

#### Whiteness

Whiteness plays a decisive role in determining the colors produced in four-color printing. Art papers have coatings that enable a very high level of whiteness. This produces brilliant multicolor prints. The hue of the blank paper has a decisive effect on the color reproduction.

#### Measuring Techniques

Specific measuring techniques and measuring instruments for print control can be employed to measure the described quality parameters. The primary measuring techniques used for determining quality are:

- densitometry,
- colorimetric measurement,
- gloss measurement,
- measurement of register differences,
- measurement of whiteness (whiteness meter, spectrophotometer),
- determining the screen frequency,
- determining the sharpness of contours (measuring microscope).

There are a large number of control elements that can be integrated in the printed image. They support metrology, but are also used to visualize the deviations affecting the quality of the print. Measuring techniques are explained in greater detail in [sections 1.4.1, 1.4.4 and 2.1.4](#).

## 2.1.2 Sheet-fed Offset Printing

Sheet-fed offset printing has impressive economic and qualitative advantages over other printing technol-

ogies. Fundamental attributes of sheet-fed offset are flexible production options and the relatively economical production of printed products of a very high quality for a wide range of print volumes. The color combination ranges from one to four-color prints up to twelve-color prints (with perfecting). In sheet-fed offset printing, substrates of different sheet sizes and grammages are processed and these can generally be obtained off-the-shelf at short notice.

Just as important for the client as the free choice of format is the range of special substrate qualities. The great variety of standard substrates for sheet-fed offset necessitates well-organized stock-keeping in the paper industry. In-line or off-line finishing operations, such as coating, imprinting, numbering, perforating, and punching are popular technologies used in sheet-fed offset. And finally the sheet finishing variants available are virtually inexhaustible.

A sheet-fed offset press must basically perform the following tasks:

- provide a high-precision conveyance of the flexible substrate at high speeds, under very dynamic, process-specific strains;
- enable a complicated printing process, involving several material flows (of dampening solution, ink, paper, air), to run in a controlled and reliable way.

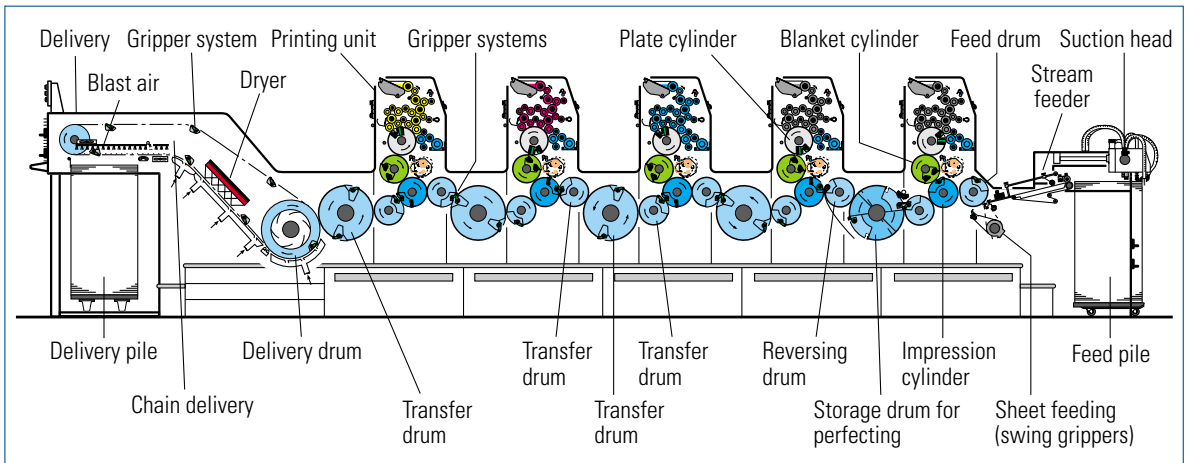
### 2.1.2.1 Paper Travel

High-precision conveyor systems, guide elements, and monitoring systems are necessary in order to route the sheet from the feed pile via the feeder, through the printing units, and finally to the delivery, where the printed sheet is stacked in a pile again ([fig. 2.1-18](#)). In the *feeder area* the sheet is mostly conveyed by suction and friction, whereby the top sheet of the feeder pile is lifted by suckers (the so-called suction head) and routed to the feed table where it is guided between rollers, belts, and brushes. Each sheet is aligned with great precision before it is fed to the printing units. For this purpose it must be slowed down to be aligned to the front and side guides, which usually takes place when the sheet is completely stationary. It is then taken over by grippers, accelerated to production speed and transferred to the printing units. In presses of the 70 cm × 100 cm format class that typically produce 15 000 sheets an hour, the sheet is transported at speeds of approximately 3.5 m/s. Gentle acceleration to printing speed is achieved by suitable sequences of movement of the feed drums or swing gripper systems.



In the *printing units* (fig. 2.1-18) the sheet is fed to the impression cylinder. Held by gripper systems (fig. 2.1-19), it passes under the blanket cylinder as the cylinders continue to revolve and the image is transferred onto the sheet. It is then passed on to the transfer drum to be conveyed into the next printing unit or into the

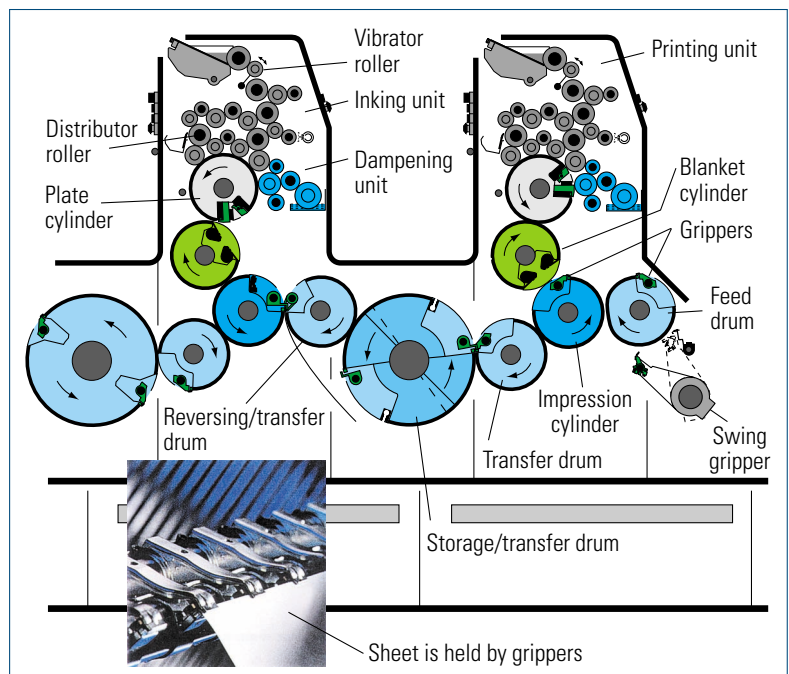
delivery. The printing process necessitates a certain contact pressure between the plate cylinder and the blanket cylinder and between the blanket cylinder and the impression cylinder in order to transfer the ink. The contact pressure must be set according to the surface structure and thickness of the paper. This is usually



**Fig. 2.1-18** Sheet conveyance in a sheet-fed offset press in unit design (Speedmaster SM 74-5-P-H, Heidelberg)

**Fig. 2.1-19**

Sheet conveyance between printing units for perfecting or straight printing (Heidelberg)

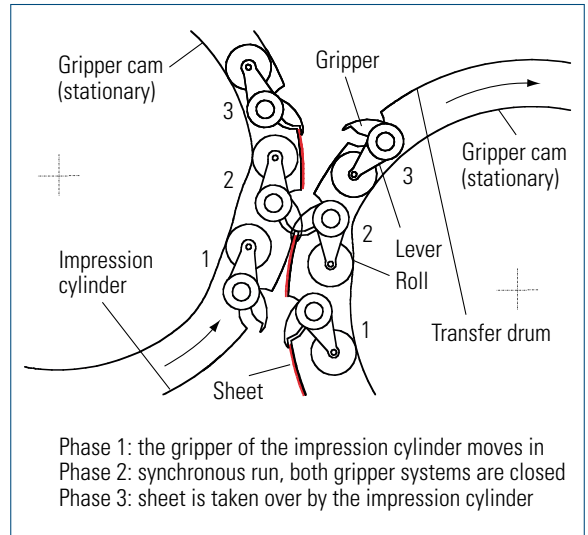


done by suitable adjustment of the blanket cylinder in relation to the impression cylinder, which does not affect the contact pressure between plate and blanket.

Offset inks are stiff, highly viscous, and consequently sticky. So that the paper does not stick to the blanket at the areas to be printed, the grippers have to pull the sheet with such a great force that it can come free of the blanket cylinder. To release the paper from the blanket, it needs to be pulled off by the grippers; this means the grippers must operate with the appropriate clamping force. In spite of the considerable gripper closing force that needs to be applied, the gripper pads should leave as few marks as possible on the print and should also be resistant to wear and tear. To ensure that the sheet is held reliably in position, appropriate gripper covering materials are used (e.g., polyurethane, ceramic) and the gripper pads have a special surface structure (grooved, roughened). Nevertheless, for physical reasons there is a certain overtravel of the substrate on the blanket cylinder, as illustrated and explained in greater detail in [figure 2.1-54](#) and [section 13.1.3](#) ([fig. 13.1-51](#)).

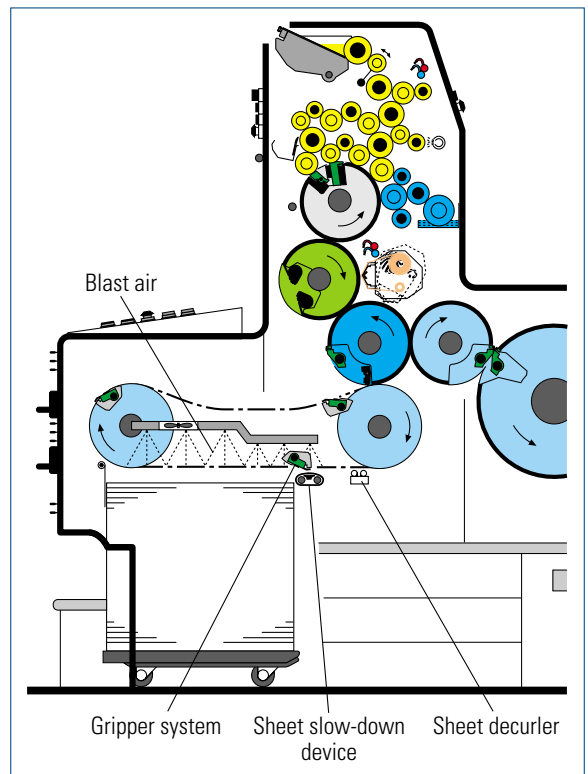
After printing, the sheet is transferred to the next cylinder. This transfer from cylinder to cylinder, from gripper system to gripper system, must be concluded after a cylinder rotation of only a few degrees of angle. In this angle range the sheet is held for a short period by two gripper systems on the two cylinders at the same time (“synchronous movement”). If this synchronous movement takes too long, the sheet will tear at the gripper edges. The cam control, which brings about the opening and closing of the grippers, needs to operate in an extremely accurate way and must be optimally adapted to the motion sequences as well as the acceleration and deceleration forces (deceleration torque) present. Gentle and scarcely audible gripper closure can be ensured by suitable design of the cam control in relation to the dynamic behavior of the gripper system’s components during the closing process. The movement of the grippers and the location of the front edge of the sheet are illustrated in [figure 2.1-20](#).

The sheets lie on the *transfer drum* ([fig. 2.1-18](#)) of the next printing unit with the freshly printed ink directly on the drum surface. Since the ink is not yet sufficiently dry, ink may be transferred to the surface of this drum during contact. Ink may collect there and smear subsequent sheets. A simple way of avoiding smearing is to position support wheels instead of closed surfaces in the image-free strips between the print pages. However, the necessary repositioning of these support wheels for each new print job is tedious and time-con-



**Fig. 2.1-20**

The different gripper control stages up to the sheet transfer



**Fig. 2.1-21** Chain delivery for standard pile delivery (Heidelberg)

suming, and more often than not there are no suitable image-free zones on the sheet where the wheels could be positioned. Other solutions had to be found. Solutions currently in use to prevent smearing of the freshly printed sheet by selecting suitable materials and surface structures are described in [section 2.1.2.4](#).

The other inks are printed on the sheet when it passes through the following printing units. The sheet transport from printing unit to printing unit has to be extremely accurate and in register and the print images of the individual color separations must be accurately aligned – for high quality jobs at an accuracy of 0.01 mm to one another. These demands on sheet transport, in addition to the high production speeds, impose considerable requirements on the press drive and on the synchronous operation of all printing units.

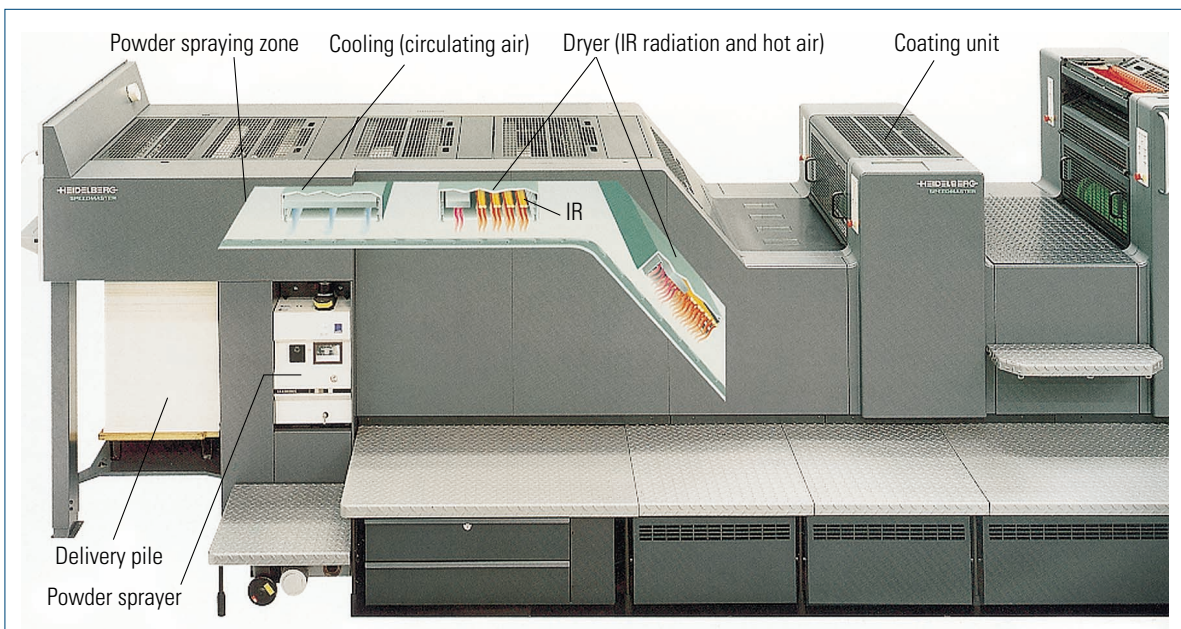
Before the sheet is stacked in the *delivery pile* ([figs. 2.1-18](#) and [2.1-21](#)) after it has left the final printing unit ([fig. 2.1-22](#)), most press configurations involve other process steps such as coating, drying, or at least powder spraying and sheet decurling. On its way from the final impression cylinder to the delivery pile, the sheets are conveyed at production speed in chain systems and held by grippers. When the sheet arrives in the delivery it needs to be slowed down so that it can be gently

dropped down on an air cushion onto the delivery pile in a stationary condition. The drying and solidification of the ink (by absorption and oxidation) that is required for the further processing steps of the printed sheets usually takes place in the pile.

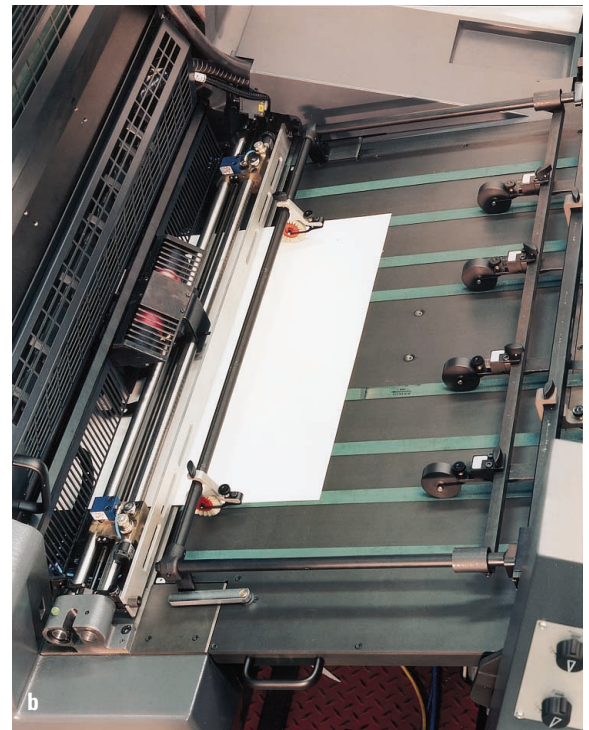
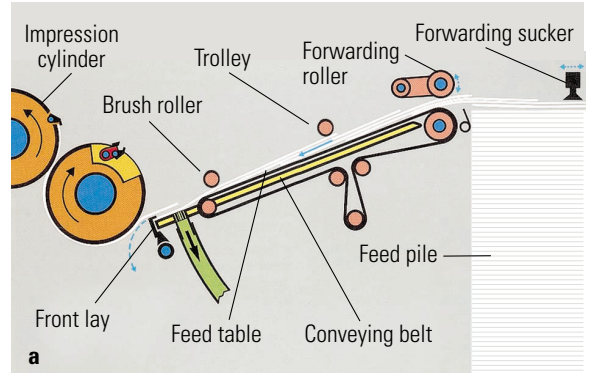
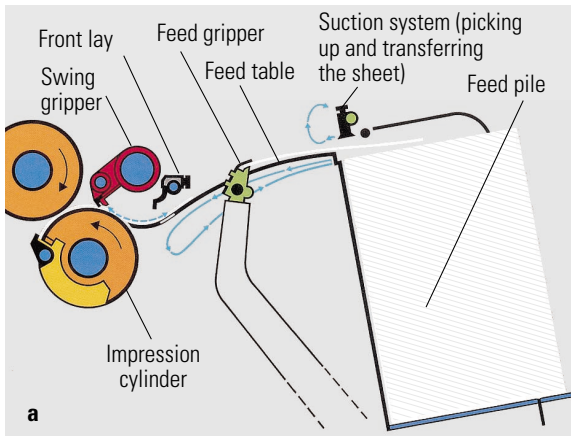
### 2.1.2.2 Feeders

There is a great variety of constructive solutions for feeder variants used in printing and print finishing machinery. *Single-sheet feeders* ([fig. 2.1-23](#)) or *stream feeders* ([fig. 2.1-24](#)) are found on sheet-fed offset presses. The single-sheet feeder has the advantage that it is easier to adjust to the sheet size and the paper quality. High-speed presses processing large formats, on the other hand, are exclusively equipped with stream feeders, so that the highly dynamic processes and the accurate sheet alignment can still be mastered in accordance with quality requirements.

The *feed system* has the task of picking up the sheets from the feed pile, separating them, conveying them to the feed table via a feed system, and aligning them at the feed guides. Since each sheet is individually aligned at the feed guides ([fig. 2.1-25](#)) the print image can be positioned on the sheet with an adequate degree of accuracy (position in relation to the paper



**Fig. 2.1-22** Press components after the printing units: coating unit, various dryers, powdering unit, high-pile delivery (Heidelberg)



**Fig. 2.1-23** Single-sheet feeder.  
**a** Diagram of the sheet transportation;  
**b** Example of a single-sheet feeder (Heidelberg)

**Fig. 2.1-24** Stream feeder.  
**a** Diagram of the sheet transportation;  
**b** Example of a sheet stream feeder (Heidelberg)

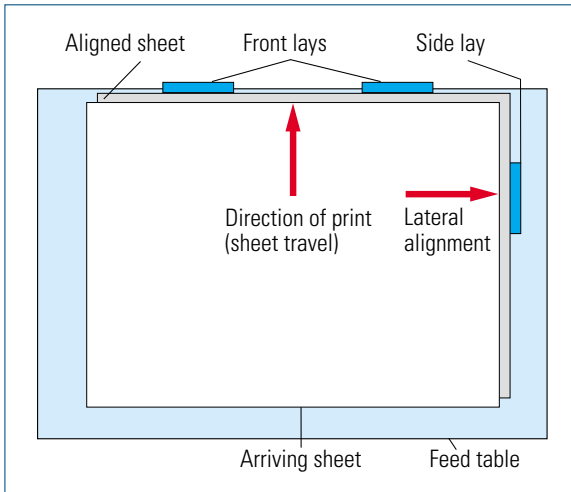
edges and, if applicable, to a preprinted image on the front or reverse side). No inaccuracies at all should be recognizable on the finished product with the naked eye. Poor sheet feeding might result in register errors during a second pass to print another color, therefore an extremely high level of feed accuracy is called for here. Alignment inaccuracies associated with the position of the print image in relation to the sheet edges are often only noticeable during finishing and/or have a visible detrimental effect on quality after trimming, folding or punching.

### Single-Sheet Feeder

A single-sheet feeder feeds the sheets to the feed table. While this is happening, the sheet is usually lifted near the front edge by several suckers (fig. 2.1-23) and taken

to a position at which either the feed gripper or the conveyor belts can take over the sheet. From there the sheet is then transported to the *front and side lays*, where it is aligned.

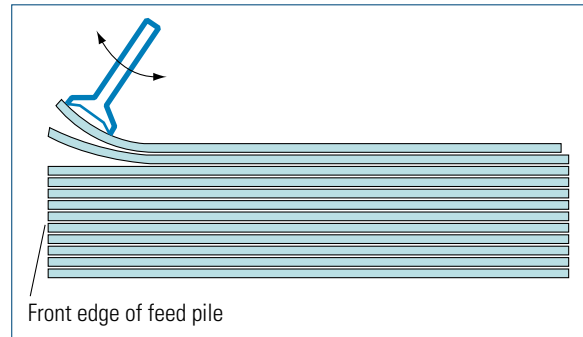
The separation of the top sheet from the feed pile in order to transport it to the feed table is a difficult task, which is basically solved by the interaction of suction



**Fig. 2.1-25** Sheet alignment on the feed table at front and side lays

and blower systems. Two sheets occasionally stick together as a result of electrostatic charges or get caught at the cut edges. To prevent these “double sheets”, separators and blast air are used to support the safe separation of sheets. Undetected double sheets might, under certain circumstances, damage the blanket and the grippers in the press. Unprinted sheets in the delivery pile can also trigger malfunctions and spoiled products as a result of undetected double sheets. The clean separation of the sheets is monitored in the feeder area by a *double sheet detector*.

The separation of sheets picked up from the pile is supported by suitable measures. Air blowers that blow against the front and rear edge of the pile fan the upper sheets. As each individual sheet is being lifted, mechanical sheet separators separate any sheets sticking to the top sheet. In simple systems (fig. 2.1-23) separation takes place at the front edge of the pile by means of an adjustable tilting motion. While this is happening, the sucker bends the front edge of the sheet, as a result of which adhering sheets are pushed slightly apart and can be separated much more easily. Another factor supporting this separation process is the stiffness of the substrate (fig. 2.1-26). With single-sheet feeders, the following sheet can only be lifted by the suckers when the previous one has completely left the feeder pile. This affects the conveying speed in the feeder area, being approximately the same as the production speed, making the time available for sheet alignment correspondingly short.



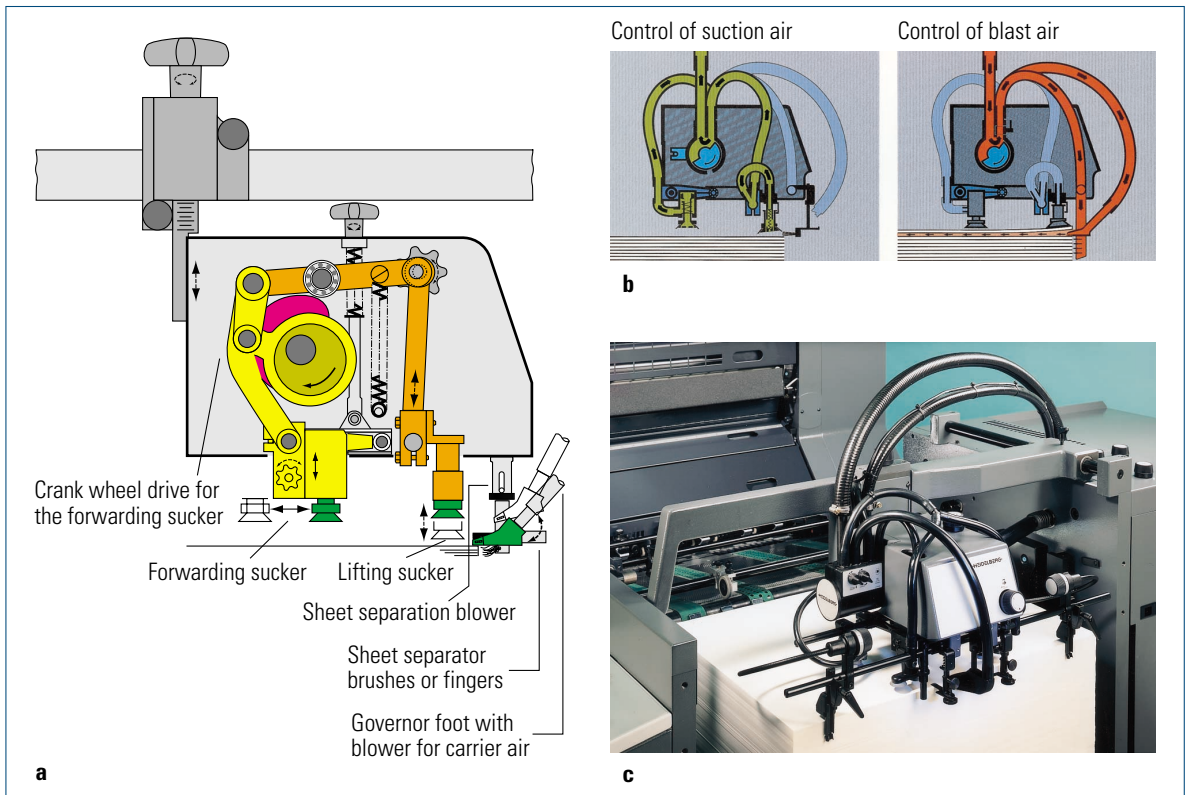
**Fig. 2.1-26** Sheet separation by sucker tilting

### Stream Feeder

With stream feeders (fig. 2.1-24) the sheets are separated initially by a *suction head* (figs. 2.1-27 and 2.1-18) at the rear edge only. Lifting suckers lift the rear sheet edge, and here again sheet separation is supported by blast air and sheet separators. Cycled blast air is now blown between the sheets and causes the entire sheet on the feed pile to float on an air cushion. In another movement sequence the sheet is fed to the stream of sheets on the belt table using forwarding suckers. The next sheet is lifted from the pile when the preceding sheet is about a third of the way along the feed pile. The rate of motion of the sheet stream is in this example approximately a third of the production speed, as a result of which it is in fact possible to achieve high production speeds while at the same time maintaining high sheet-alignment accuracy.

A *forwarding roller* on the belt table, which runs synchronously with the press, clamps the sheet upon its entering the belt table, thus placing it into synchronous movement with the sheet stream. The time of arrival of the sheet in the feed guides is determined by the moment the sheet is clamped on the forwarding roller. Slight variations in the sheet stream may lead to early or late sheets. The arrival of the sheets at the feed guides is subject to a certain variation. To avoid press stoppages and ensure a proper sheet alignment at the *front and side lays*, the sheet arrival is set to a mean value of the optimal feeding time and the range of variation optimized by adjustments at the feeder.

The sheet separation process and the feeding of the sheets into the sheet stream essentially depend on the substrate. Differences in surface properties, paper thickness, grammage, porosity, electrostatic charges and so on affect the sheet travel. Therefore, it must be



**Fig. 2.1-27** Suction head.

- a** Diagram of sucker, blower and conveying system;
- b** Suction and blast air control;
- c** Suction head on a stream feeder (Heidelberg)

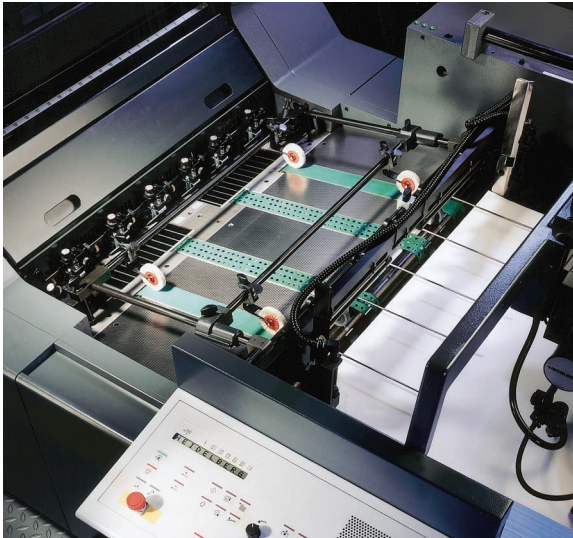
possible to adapt the entire feed system to extremely varied paper qualities. Since with high-speed presses the feed behavior of the sheet cannot be followed by the naked eye alone, state-of-the-art accurate measuring, display and control systems are used to monitor the sheet travel from the feeder through to the delivery.

The two feed systems, the *stream feeder* and the *single-sheet feeder*, are very different in their structural design, the way they are set, and their application. The single-sheet feeder has the advantage that its structural design is comparatively simple, which makes the operation uncomplicated. The single-sheet feeder requires significantly shorter set-up times for a change of format but is, in principle, only suitable for smaller formats and lower printing speeds. Using a single-sheet feeder on a high-speed, large-format press would lead to erratic movements. It was also necessary to have

sheet transport that is free of scratches and abrasion for stream feeders. This is resulted in a feeder table using stream feeders which are easy to adjust. This led to the development of a *suction tape feeder table* (fig. 2.1-28) which operates without pressure rollers acting from above upon the sheet. The transport of the sheets is only assisted by brushes when necessary.

### Double Sheet Detectors

Any double or multiple sheets (i.e., two or more sheets are picked up together and guided to the feed table) must be detected in good time if subsequent damage is to be ruled out. As soon as a double sheet is detected in the feeder, the feeder stops the conveyance of this double sheet and any following sheets. The press control usually ensures that the preceding sheets are printed and transported to the delivery. As can be seen from table 2.1-2, the



**Fig. 2.1-28**  
Stream feeder with suction tape feed table (Speedmaster SM 74, Heidelberg)

different double sheet detection systems all have certain limitations in the identification of different substrates.

In many cases double sheet detectors still operate mechanically and usually have to be adjusted to the substrate thickness. They have certain limits with respect to their sensitivity, as in the case of light-weight papers. The operation of optical double sheet controls is very much easier, as they adjust themselves to the material thickness at the start of the sheet travel. In addition to position sensing systems, double sheet detectors mainly use radiation intensity damping with infrared or ultrasonic systems to measure the sheet thickness. The capacitive measuring system is particularly suitable for thick substrates but its application is severely limited for substrates containing moisture.

### Sheet Alignment on the Feed Table using Three-Point Alignment

Alignment precision has to be met within sufficiently narrow tolerances wherever a sheet has to run through the press a second time. This applies for the front and reverse sides with straight printing and perfecting, it applies for finishing at the paper cutting unit, at the folder, and also for punching, embossing, or creasing. It also applies for a second sheet pass when imprinting other colors such as decorative colors for multi-

System	Systems with contact		Systems without contact		
	mechanical	inductive	optical	acoustic	capacitive
Measuring principle	Distance measuring		Damping the output signal (the intensity of the signals is lower with double sheets)		Changing the capacity
	Lever system acting on a switch	Lever system acting on inductive distance sensors	Transmitted light	Ultrasound	Measuring the capacity between sensor and sheet guide plate
Suitable for substrates such as: paper/board with grammages of about	> 60 g/m <sup>2</sup>	> 40 g/m <sup>2</sup>	28 (Bible paper) up to 170 g/m <sup>2</sup>	> 28 g/m <sup>2</sup>	> 120 g/m <sup>2</sup>
Metallized substrates	X	X		X	
Foils, credit cards	X	X		X	(X)
Envelopes (made of 2-ply paper)	(X)	(X)			X

**Table 2.1-2** Double sheet detection systems and their applications (selection); remark: (X) with limitations

color printing, and for spot coating or hot foil stamping.

To align the sheet on the feed table with the required accuracy, it is usually aligned at two *front lays* and one *side lay* (fig. 2.1-25). On large format presses, which are equipped with six front lays, unneeded front lays are disengaged when smaller formats are processed, so that only two front lays are used for the alignment. To be able to align the printed sheets at the same side for the finishing operation, the alignment points have to be marked in the printed product (e.g., manual marking in the delivery pile). Whether these alignment points must then be used in finishing depends on the product and the required tolerances. Since there are different alignment systems in printing and finishing, it is very important for the front edges of the sheets to be cut as straight as possible and within narrow tolerances, as well as for the angle between the front and side edges to deviate as little as possible from an exact right angle.

The accurate position of the print image on the sheet can only be achieved if each sheet is aligned individually before it enters the press. During the actual alignment process, the sheet is pushed or pulled with light force against the alignment guides. Guide elements, such as belts, brushes, rollers, pulling segments, or the suction plates of the side guides, slide gently over the sheet and, assisted by sliding friction, take it to the correct final position. It must be possible to adjust the sheet feeding systems to allow for the great variety of sheet sizes, the variable sheet thickness, and the different sliding friction of the different sheet surfaces. Exact alignment is made more difficult if the sheets do not lie completely flat and have a certain waviness at the edges. With suitable components in the feed area (e.g., pull lays and rotary suckers) the lead edge of the sheet can be tensioned so that it lies flat.

**Side Lay.** The side alignment of each individual sheet takes place at the side lay, by means of push or pull lays (figs. 2.1-29 to 31). Pull and push lays are press elements that ensure the exact lateral alignment of the sheet before it is transferred to the printing units.

*Push lays* (fig. 2.1-29) are of simpler design and are easier to adjust than pull lays. They should be used when processing smaller sheet sizes. The functionality of push lays has certain limitations with large formats and insufficiently stiff substrates. To align the sheet, it is pushed a few millimeters sideways against a stop (side lay) by a pushing piece acting at a right angle to the direction of travel. Consequently, the push guide exerts an accelerat-

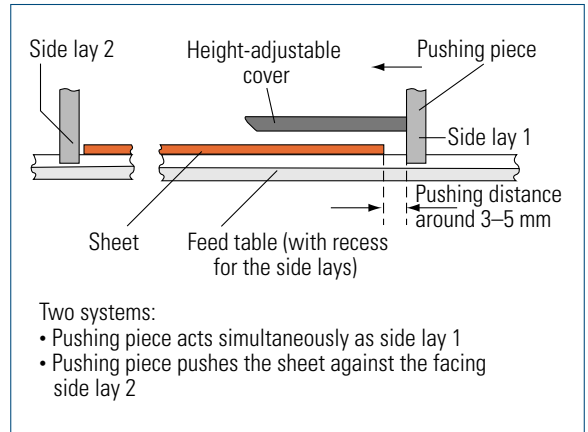


Fig. 2.1-29 Push lay

ing force on the sheet, which may buckle and bend it. The higher the speed of the press, the bigger and less stiff the sheet, the greater the risk that the sheet will be deformed and cannot be fed accurately. Some feed tables are slightly bent in the direction of sheet travel, which gives the sheet greater stiffness for the lateral alignment. To feed stiff cardboard, on the other hand, a flat feed table is required, otherwise the cardboard will buckle and/or lift.

High-speed, large-format presses are usually fitted with *pull lays* (fig. 2.1-30). Pulling the sheet from one

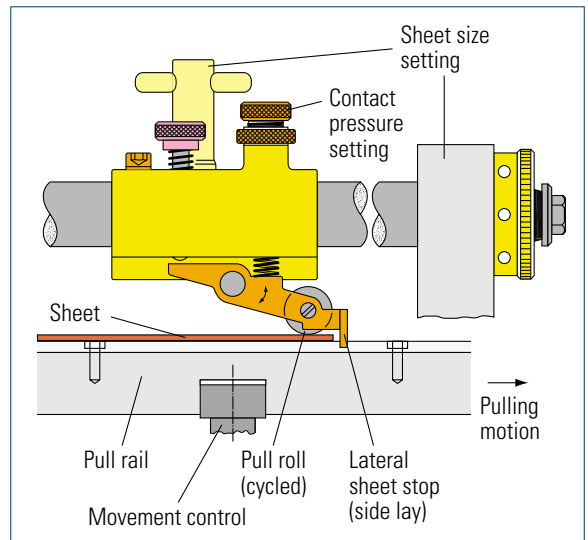
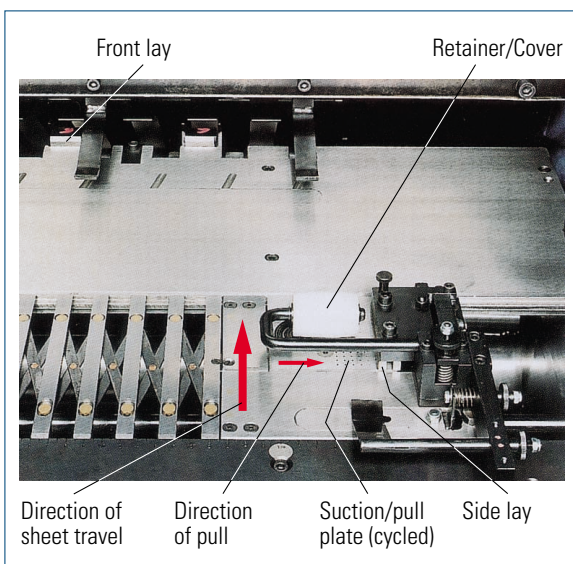


Fig. 2.1-30 Pull lay for lateral sheet alignment



side tensions the front edge. Waviness at the edges of the sheet is smoothed by the pulling action. A sheet tensioned crosswise to the direction of transport at the front edge can be transferred from gripper system to gripper system considerably more accurately than a wavy sheet, especially in multicolor presses. Doubling effects (see sec. 2.1.1.4) contingent on the substrate are also avoided in this way. The pull lays work in two ways: The sheet is pressed against a pull rail (fig. 2.1-30) or is sucked onto a suction plate (fig. 2.1-31). This pulling segment tracks the sheet until the edge of the sheet touches the side guide. The pulling segment starts to slide over the sheet as a result of this increased resistance. This transition from adhering to sliding has to be adjusted in accordance with the substrate. The contact pressure of the pulling segment on the substrate is set mechanically via an adjusting screw and contact spring or via the vacuum when using a suction plate (fig. 2.1-31).

**Front Lay.** The two front lays act as stops for the sheet, which is usually fed at low speed by conveyor belts via the feed table. The aim of this is the exact alignment of the sheet in the travel direction (direction of print). The front lays remain in their start position/alignment position until the swing-arm grippers close (fig. 2.1-33). They are then moved out of the travel line of the sheet, before the swing gripper moves along with the sheet in the direction of the print. The front lays



**Fig. 2.1-31** Pneumatic pull lay (KBA)

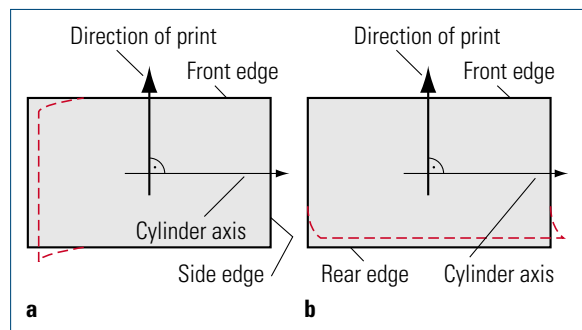
then return to their alignment position. When the sheet makes contact with the front lay it has a tendency to bounce back slightly. To compensate for this effect and to align the sheet perfectly for its further transportation, it is pressed lightly against the front lay with the help of suction tapes, rollers, and/or blower/suction nozzles. Another option for accurate alignment is to swivel the front lay back slightly toward the sheet after the sheet has touched it.

### Sheet Reversal

Sheets are usually printed on both sides. To achieve this, they have to pass through the press a second time, unless a perfecting press is being used, in which straight printing and perfecting can be done in one pass.

**Work and Turn.** For the second pass (verso printing) the sheets are usually turned over before being pre-piled again. This means that the pile is turned so that the side edges are changed over (fig. 2.1-32a).

So that the sheet can always be aligned at the same three points, the sheet-fed offset press needs a second side lay on the opposite side from the first side lay. After work and turn, the second side lay has to be used to ensure an accurate register alignment. The change of side lay after work and turn only becomes unnecessary if all sheets in the pile are of the same size. Only then can the accurate register alignment be ensured for the front and reverse sides without having to change the side lays.



**Fig. 2.1-32** Turning the sheet pile.

**a** Work and turn: Turning the sheet round the axis of the direction of printing, the right edge becomes the left edge, the front edge remains the same;

**b** Work and tumble: Turning the sheet round the axis perpendicular to the direction of printing, the front edge of sheet becomes the rear edge of sheet. The side edges stay the same

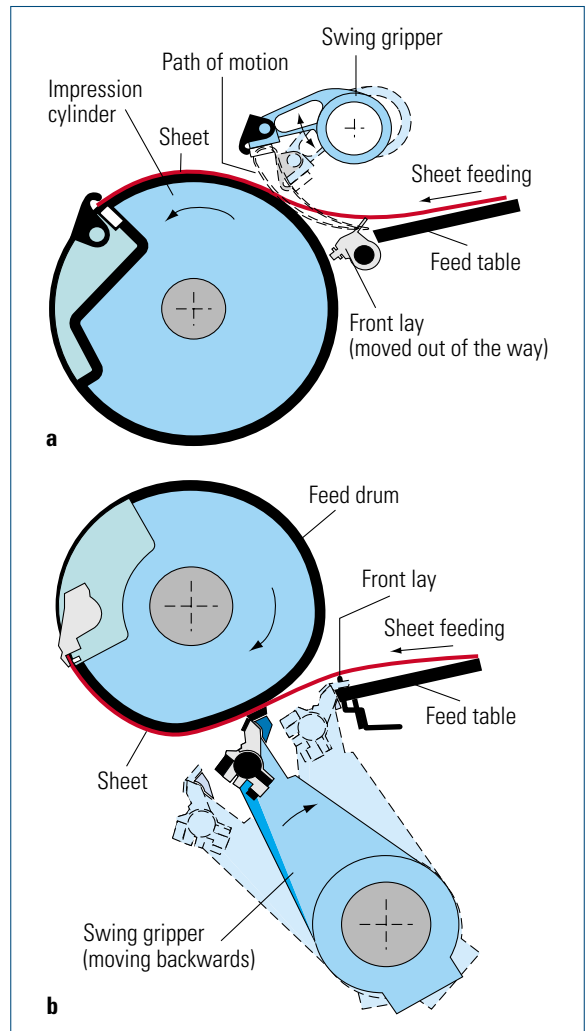
In practice, however, there are sheet-size tolerances in the production print sheets, meaning that the individual sheets differ in size slightly within a pile. The knife on the guillotine cutter can deviate (under or over-cutting) or the sheet “works” and changes its size due to moisture absorption and ambient temperature. The problem here is that the change in sheet sizes can differ considerably from section to section within the pile. Already in the first sheet pass, the sheets in the pile are not equally dimensioned and the differences from section to section are even greater in the second pass. However, since the side guide is changed after work and turn, so that the sheet is aligned at the same three feed points for straight printing as for verso printing, an accurate register can be maintained throughout the print run for both sides. This production accuracy for the finished product can, however, only be achieved if the same alignment points are used throughout all finishing operations.

**Work and Tumble.** The pile can also be inverted to print the second side, which means that the edge of the sheet that was the front edge for the first side becomes the rear edge for the second side (fig. 2.1-32b). In this way the lead edge of the sheet becomes the rear (trailing) edge. With work and tumble, exact straight printing and verso printing register can only be achieved if the distance between the front and rear edges of each individual sheet is exactly the same throughout the entire print run. As already explained, the paper’s dimensions may change and this makes it necessary for all four sides of the sheets to be trimmed shortly before printing. Work and tumble layouts must include two *gripper margins*, whereas with work and turn one gripper margin suffices. It is on account of these complexities that work and tumble is only rarely used.

### Infeed Systems to the First Printing Unit

Between the feeder and the first printing unit a section is needed where the sheet is accelerated. The sheet is stopped on the feed table and the sheet is aligned at a complete standstill. The impression cylinder moves constantly at printing speed. The infeed system now has the task of bringing the sheet, guided accurately in grippers, up to production speed and passing it on to the grippers of the impression cylinder.

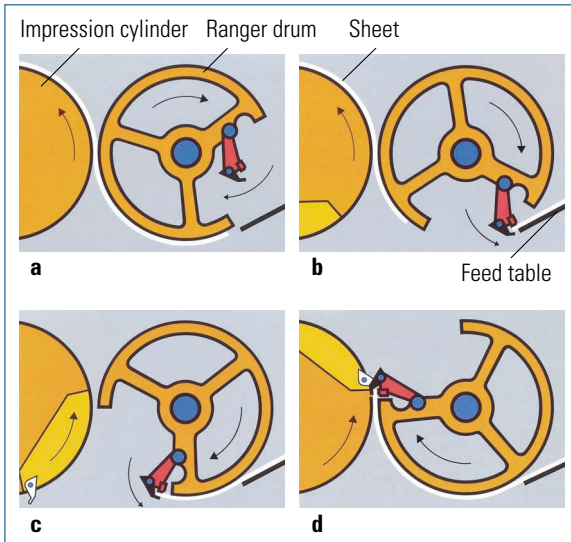
In many presses this task has been solved by *swing grippers* (fig. 2.1-33). Distinction must be made between *swing grippers* that lie above the sheet and *swing grippers* arranged under the sheet.



**Fig. 2.1-33** Swing gripper.

- a** From above;  
**b** From below

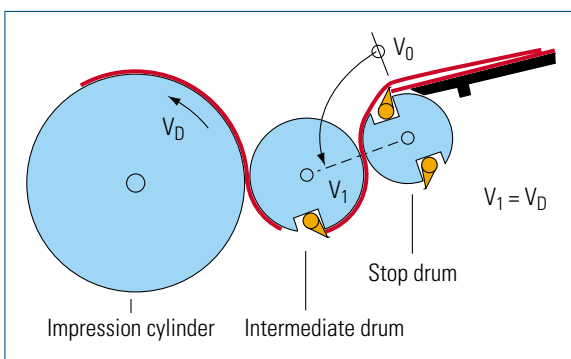
With the “*Ranger drum*” (fig. 2.1-34), named after the English inventor, Ranger, a constant, circular motion of the feed drum was achieved. Here, it is only the group of grippers that performs a relative motion opposite to the uniform rotation of the drum. Before reaching the feed table, the grippers move slightly faster than the rotation of the drum. During transfer of the sheet they remain stationary at the feed table for a short moment, pick up the sheet, and then accelerate to printing speed again on their way to the impression cylinder. This se-



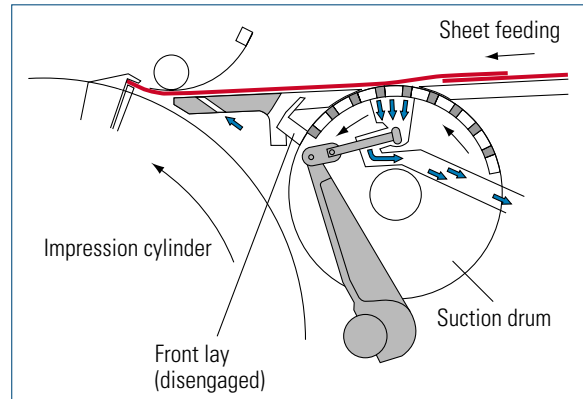
**Fig. 2.1-34** Ranger drum, sequence of functions.  
**a** Initial position;  
**b** Gripper swings towards the stationary sheet and grasps it;  
**c** Sheet is slowly accelerated up to printing speed;  
**d** Transfer of the sheet to the impression cylinder with synchronous movement (Heidelberg)

quence of movements is controlled by a special cam control system.

The *stop drum system* (fig. 2.1-35) represents another option for picking up the stationary sheet from the feed table, accelerating it, and transferring it to an intermediate drum, from where it is transferred in true register to the impression cylinder.



**Fig. 2.1-35** Stop drum system; stop drum accelerates the stationary sheet up to printing speed (KBA)



**Fig. 2.1-36** Suction drum system (KBA)

With the *suction drum system* (fig. 2.1-36), the aligned sheet is transferred directly to the impression cylinder grippers via suction drums (e.g., four), which are arranged next to each other.

### 2.1.2.3 Printing Units

The printing unit is a sub-assembly of the press (see figs. 2.1-18 and 2.1-19) that consists of a plate, a blanket, an impression cylinder, an inking unit, and a dampening unit. Transfer drums that transfer the sheet to the next printing unit can also be classed as part of the printing unit. Printing units can also be equipped with wash-up devices and automation systems just as for feeding the plate.

The *inking unit* in a sheet-fed offset press (fig. 2.1-19) is designed as a roller-type inking unit with numerous rollers to evenly ink the printing plates with an area coverage and corresponding ink requirement. The quantity of ink required by the printing plate is mostly supplied from the ink fountain to the inking unit via a fountain roller and a vibrator roller. Zonal setting of the ink feed depending on need of printing plate, at right angles to the direction of printing, is done with ink-adjusting screws or ink-adjustment segments (see sec. 2.1.1.3). Makeready times are considerably reduced by using automated ink key presetting systems. To do so, the necessary data for the color combination is determined from digital prepress or by means of a printing plate scanner by measuring (plate image reader; see sec. 2.1.4.1). The inking unit also has inking rollers that perform an axial oscillating movement (see fig. 2.1-19). This *lateral distribution* ensures that the ink profile set is evened out slightly at the transition points and that

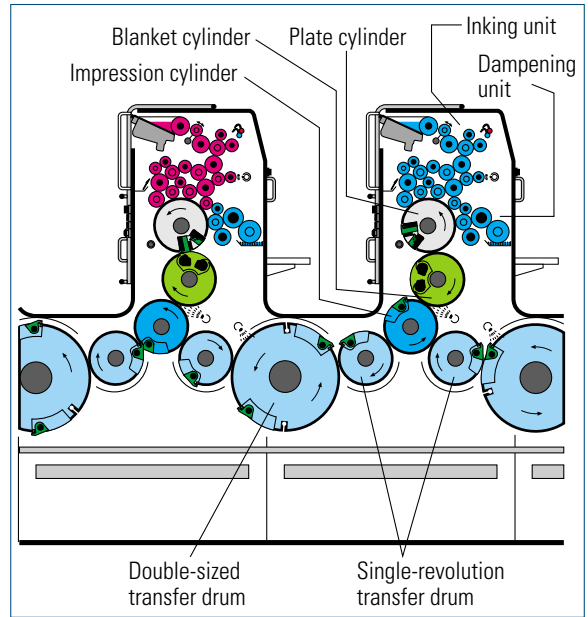
even inking occurs. It is, above all, the *distribution rollers* (especially those close to the ink form rollers) that break down or smooth out the resplit ink profile in the circumferential and axial direction of the rollers. Due to the cylinder gap on the plate cylinder there is no continuous flow of ink from the inking unit. In connection with the ink accepted by the printing plate in accordance with the image and the generally discontinuous supply of ink from the ink fountain into the inking unit via a vibrator roller (fig. 2.1-19), there is a variation of the ink film thickness on the printing plate in the circumferential direction. This is referred to as “gradual fading.” The profile of the ink film thickness on the plate in the circumferential direction can be influenced by the phase position of the axially reciprocating distributor rollers in relation to the plate cylinder gap (starting point of lateral distribution). With high-grade inking units it is possible to adapt this phase position to the printing plate. More recent inking unit developments enable remote adjustment. The color setting data from prepress can be used to calculate the optimal starting point for lateral distribution.

The *dampening unit* can be designed as a continuous-type dampening system for the application of minimal quantities of dampening solution. A dampening unit is not required in waterless offset printing; that is, when plates and inks are used for waterless offset printing, the dampening unit is switched off (for waterless offset printing, the printing unit is fitted with a temperature control unit and/or cooling unit).

The ink flows from the inking unit via the plate, the blanket and the impression cylinders. This group of cylinders operates with considerable reciprocal interaction. These three cylinders form a unit within the printing unit. There are various cylinder configurations. One blanket cylinder may, for example, be inked by two plate cylinders or the sheet may be printed by several blanket cylinders on one impression cylinder (see sec. 1.6.2.1). The most important configurations are discussed in detail below.

### Three-Cylinder System

The three-cylinder system (fig. 2.1-37) has become the most widely-used in sheet-fed offset printing. Presses for multicolor printing are put together in *unit construction* (as shown in fig. 2.1-18), which are connected by sheet transfer systems. The fact that all the printing units in a multicolor press are identical has many advantages in manufacturing terms and also regarding operation. There are also process-related advantages,



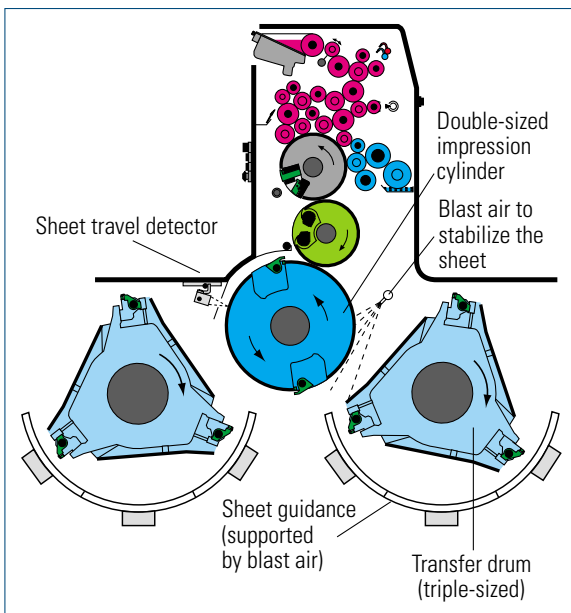
**Fig. 2.1-37**  
Printing unit in a 3-cylinder design with single-revolution transfer drums

such as the same drying periods for the color separations that are printed in sequence.

Most components and operating elements are identical from printing unit to printing unit throughout the entire press. In virtually all presses in the three-cylinder group, the bearers of plate and blanket cylinders run in direct contact, which means that the distance between the plate and blanket cylinders cannot be adjusted by the operator. The printing pressure between plate and blanket is determined by the cylinder packing (the thickness of the plate, blanket, and underlay). The distance between the blanket and impression cylinders can be adjusted via a cam control system attached to the side frames. To adapt the blanket pressure to the quality and thickness of the substrate, the blanket cylinder is adjusted during make-ready to the impression cylinder on which the substrate is located, without changing the pressure ratios to the plate cylinder. Multicolor presses in unit construction using the three-cylinder systems are usually equipped with single-sized (single-revolution) impression cylinders. However, there are some press configurations that use double-sized (half-revolution) impression cylinders.

Double-sized impression cylinders (fig. 2.1-38) were initially developed for printing on cardboard. Due to the quite considerable bending involved, very thick, multi-layer, couched cardboard would be subjected to considerable stress on single-revolution impression cylinders with a relatively small diameter, which would lead to bending marks on the cardboard. On double-sized (half-revolution) impression cylinders the bending radius is twice as large as with single-revolution cylinders, the cardboard is subjected to less stress and can be guided through the press with fewer sheet guiding elements.

The “straighter” sheet guidance also has mechanical advantages even for paper as thin as Bible paper. Less force is required to separate the sheet from the blanket cylinder with larger cylinders. There is another even more important advantage, namely the absolutely smear-free conveyance of the sheet on the transfer drum. With double-sized impression cylinders it is actually possible for the printed sheet not to be taken over by the transfer drum until it has left the nip between the blanket and the impression cylinders. As a result of the centrifugal force, the sheet is pushed outwards on the transfer drum. The unprinted outer side can be aligned at a stationary arched guide plate.



**Fig. 2.1-38**  
Printing unit in a 3-cylinder design with double-sized impression cylinder and triple-sized transfer drums (Heidelberg)

The design of the *transfer drums*, various versions of which are illustrated in figures 2.1-37 and 2.1-38, is of fundamental importance for the further conveyance of the sheet. Double-sized drums are also used instead of single or triple-sized drums. The inner side of the sheet with the wet ink must not come into contact with the transfer drum. In presses with single-sized impression cylinders, the sheet is already clamped by the grippers on the transfer drum while it is pulled off the blanket. The sheet is pressed against the surface of the transfer drum by this tensile force.

Many methods are used to prevent the ink from offsetting on the cylinder surface and the consequent ink build-up during production. The cylinders and/or the sheet guiding elements are coated with a variety of surfaces or substances, mostly in conjunction with micro-roughening/structuring. There are also special cloth coverings coated with glass beads or silicone rubber. Another very successful method is to mount a special, movable fabric jacket (fig. 2.1-39). The air cushion drum represents a relatively expensive solution.

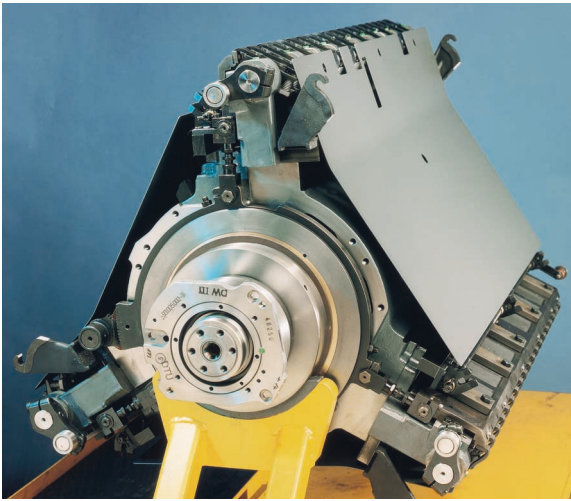
The double-sized impression cylinder in conjunction with “contact-free” sheet guidance on the transfer drum has proved to be particularly advantageous. The triple-sized transfer drum shown in figures 2.1-40 and 2.1-38 together with the air currents provide contact-free sheet transfer from impression cylinder to impression cylinder.

### Five-Cylinder System

The five-cylinder system (fig. 2.1-41) is a more compact variant than the unit construction version. Two blanket

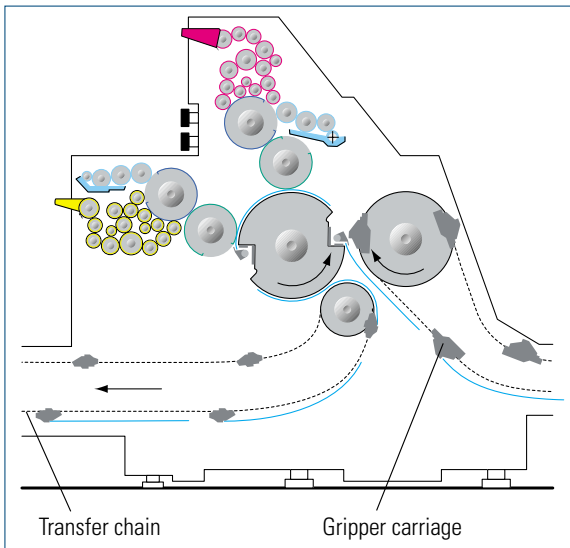


**Fig. 2.1-39**  
Fabric jacket on a delivery drum (“Super Blue”, Printing Research)



**Fig. 2.1-40**

Triple-sized transfer drum (see also [fig. 2.1-39](#); Speedmaster CD transfer drum, Heidelberg)



**Fig. 2.1-41**

Printing unit in a 5-cylinder design, with transfer chain (Roland 204 H, MAN Roland)

cylinders print onto a common impression cylinder, whereby five cylinders form one printing unit. With appropriate sheet transfer systems, compact two to ten-color presses can be built as five-cylinder systems. This type of press has marked advantages if the space in the

printshop is limited. With two-color presses there is good accessibility to the inner cylinders for cleaning and maintenance work. With longer presses, however, additional space is required at the impression cylinder for sheet transfer and accessibility is limited.

The fact that the sheet passes through the five-cylinder system with just a few gripper transfers is a distinctive feature of sheet travel in five-cylinder systems. On the other hand, there are considerable tensile forces acting on the sheet since the sheet is often printed with two inks at the same time. A disadvantage when using five-cylinder systems for multicolor printing is generally the differing lengths of time taken to convey the printed sheet from one nip zone to the next and the different drying times arising from this (see [fig. 1.6-5d](#)).

A cost advantage of the five-cylinder system is the saving of every second impression cylinder and further sheet transfer systems. Chain systems as illustrated in [figure 2.1-41](#) are used as transfer systems from the first double printing unit to the next one, but transfer drums (see [fig. 2.1-186](#)) are also found in some five-cylinder presses. Special catch arms have been designed for chain transfer systems by means of which the gripper carriages are aligned very accurately for in-register transfer of the sheet to the impression cylinder in spite of chain play.

### Transfer Systems

The cylinder groups on which the sheets are transferred from printing unit to printing unit can be arranged in various ways: mostly using three transfer drums or only one transfer drum between the printing units ([figs. 2.1-37](#) and [2.1-38](#)). Since accessibility to the printing units has to be maintained with one-revolution impression cylinders, i.e. there must be a certain clearance, these presses are usually equipped with three transfer drums. Presses with half-revolution impression cylinders can also operate perfectly well with a single double-sized transfer drum. A triple-sized transfer drum can also be used to optimize sheet transfer in such a way that the sheet is not taken over by the impression cylinder until it has left the nip between impression and blanket cylinder and there is sufficient intermediate space available between the printing units for operational purposes.

### Plate Cylinder

Significant advances have been made in the area of *printing plate change-over* in recent years, achieving very short change-over times. In spite of the obvious

advantages of technologies employable for reducing set-up times, such as automatic plate loading and special register and clamping systems, traditional working methods are still widely used for plate change-over.

The printing plate is clamped in the plate cylinder gap (fig. 2.1-42) by two clamping bars. The cylinders on sheet-fed offset presses usually have a wide gap, thereby offering good accessibility for manual mounting of the plates.

Thanks to modern set-up technology, register errors occurring during assembly, platemaking, and plate clamping are so minor that accurate positioning can be achieved by *circumferential, lateral, and diagonal register* adjustments via the control console (see sec. 2.1.4.3) without stopping the press. The remote-controlled register setting systems have an adjustment accuracy of up to approximately 0.01 mm depending on the press concept. Printing-plate-sized film imagesetter or computer to plate systems achieve notably higher precision in prepress than is achieved with manual stripping operations, especially if this work is done under time pressure. In order to fully exploit the precision achieved in prepress, the accuracy with which the plate is clamped on the plate cylinder regarding the clamp bars and register systems, must be correspondingly high. It is im-

portant here that the front clamping mechanism be fixed on the cylinder to create a solid base. More recent press models offer fixed front clamping bars of this kind as part of the standard equipment. Fixed clamping bars are also available for fully or semi-automatic plate change.

Manual plate change and registering of the individual colors take up a large proportion of time in the overall makeready process. With *automated plate change* (fig. 2.1-43), it is possible both to speed up the plate change and to clamp the plates more accurately. Even the first sheet is printed with good color register and only minor fine register corrections are required. The printer can therefore run the press up to production speed and start the fine color corrections immediately after the plate has been clamped in position. The positioning of the color separations is done by circumferential, lateral and diagonal register adjustment on the plate cylinder.

*Fully automatic plate change* from a cartridge/cassette with a supply of five to ten plates (see sec. 2.1.5.2) has not succeeded in gaining widespread acceptance. The cost of the plate guidance in the cartridges is relatively high and the advantage over semi-automatic plate-change comparatively slight. Cartridge systems of this kind are rarely used, since it is rare for sets of plates for several jobs to be available in advance and the presses that would be necessary to fill the cartridges cannot be reserved in advance.

The plates are usually aligned in relation to the plate cylinder at their *register holes* (see also sec. 3.1.5.2). If the

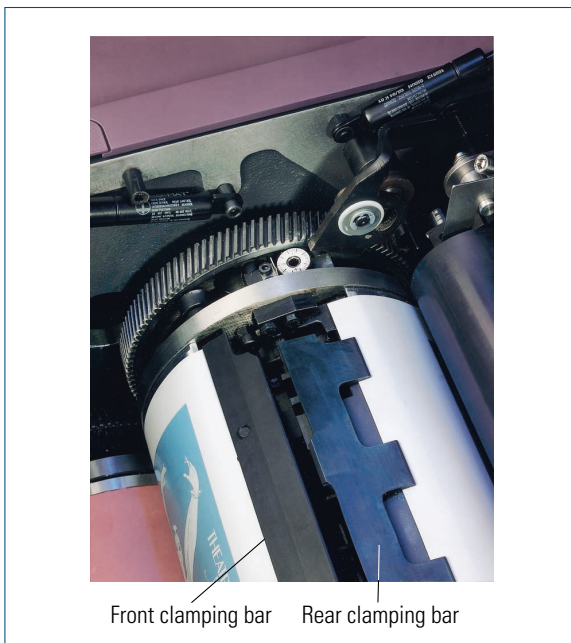


Fig. 2.1-42 Plate clamping (Printmaster QM 46, Heidelberg)



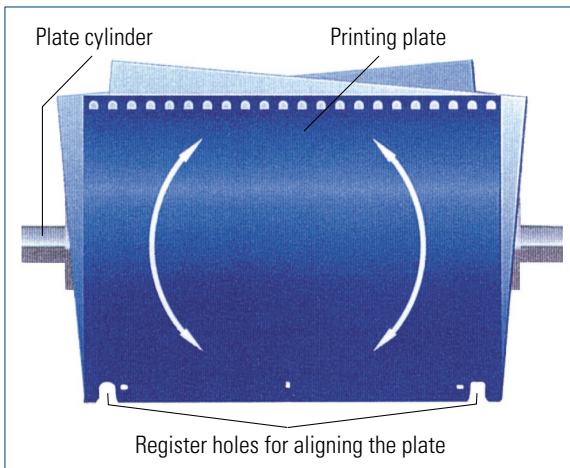
Fig. 2.1-43 Automatic plate loading (Speedmaster SM 52, Heidelberg)

print image is copied at an angle onto the plate or the plate is clamped at an angle on the cylinder, this cannot be compensated for by adjusting the lateral and circumferential register; the plate needs to be realigned on the cylinder surface. On many presses, the plate cylinders can be cocked to achieve this. There are other solutions for moving the plate, where the clamping bars in the cylinder are repositioned (fig. 2.1-44).

The plate cylinder must roll very accurately on the blanket cylinder. Slight inaccuracies of only a few microns could lead to clearly visible streaks in homogeneous halftone tints at right angles to the direction of printing, which is why there is cylinder bearer contact between the plate and blanket cylinders.

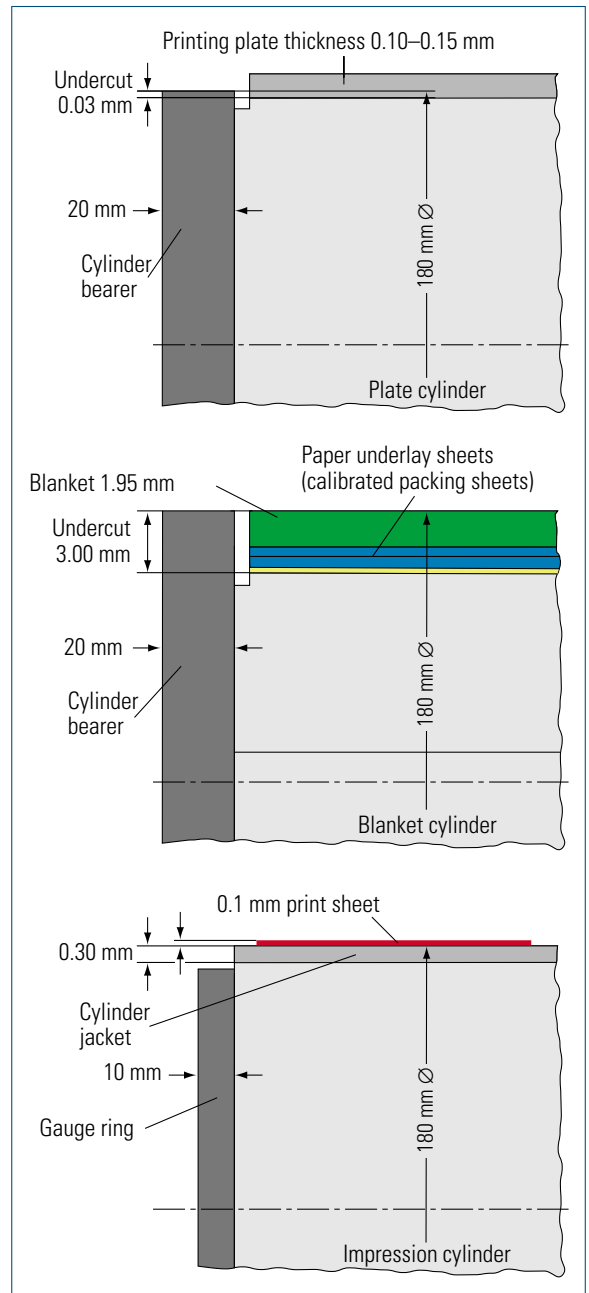
### Cylinder Bearer, Gauge Ring

In bearer-contact presses, the bearers located at each end of the plate cylinder and the blanket cylinder are in direct contact with each other. The *cylinder bearer* is of the same diameter as the pitch diameter of the driving gear. The blanket is usually underlaid with packing sheets (fig. 2.1-45) so that the printing plate exerts a contact pressure as a result of a 0.1 mm interference, in order to level out certain surface unevenness and to build up the necessary surface pressure. It has proved expedient to mount printing plates 0.1 mm above the bearer level and to underlay sheets below the blankets at the cylinder bearer level. The bearers also serve as a reference height for verifying the packing height on the



**Fig. 2.1-44**

Register adjustment by twisting the plate on the cylinder surface by changing the clamping rail position (MAN Roland)



**Fig. 2.1-45**

Example for adapting the cylinder diameters in relation to one another



cylinders. However, the primary task of the cylinder bearers is to ensure smooth running of the cylinders, which is achieved through the initial tension applied during mounting; they also help to prevent the quality-impairing and noise-producing effects of load variations as a result of overrunning the cylinder gap. Variations in bearing force may cause quality-impairing streaks in homogeneous, fairly large screen areas due to slightly varying dot gain.

There is no bearer contact between the blanket cylinder and the impression cylinder. On each side of the impression cylinder there is a *gauge ring*, the diameter of which is less than that of the bearer.

Gauge rings (measurement rings), which are fitted at each side of the plate and blanket cylinders instead of the bearers, have a slightly smaller diameter than the pitch diameter of the driving gear, so that the plate and blanket cylinder gauge rings do not touch. As the term gauge ring implies, these rings are used merely as a reference to measure the packing height. Since, in the case of non-bearer-contact presses, smooth running has to be ensured by the bearing application alone, some presses are still fitted with sliding bearings instead of roller bearings to guarantee smooth running even without bearer contact.

### Blanket Cylinder

The ink is transferred from the printing plate to the substrate indirectly via the blanket (fig. 2.1-46). Distinction is made between *compressible* and *incompressible* blankets, whereby compressible ones are more common. On account of its surface properties, the flexible blanket retains water in the non-printing areas (less transfer onto the paper) and is able to compensate for unevenness of the substrate in the printing areas. Both solid areas and halftone dots are practically transferred as though the substrate had have an ideally even surface. Since, with respect to their physical and chemical properties, blankets age and may also become damaged, they have to be replaceable. Blankets are usually fastened onto the blanket cylinder with clamping bars and clamping systems. Pre-railed blankets, which are widely used in web offset presses, are also being used more frequently in sheet-fed offset presses and can be changed quickly (fig. 2.1-47).

Calibrated packing sheets (fig. 2.1-45) are used to adjust the blanket surface to the pitch diameter of the gear wheel. There are variants where the packing material is already attached to the blanket cylinder yet underlay sheets are still inserted here between the blanket and

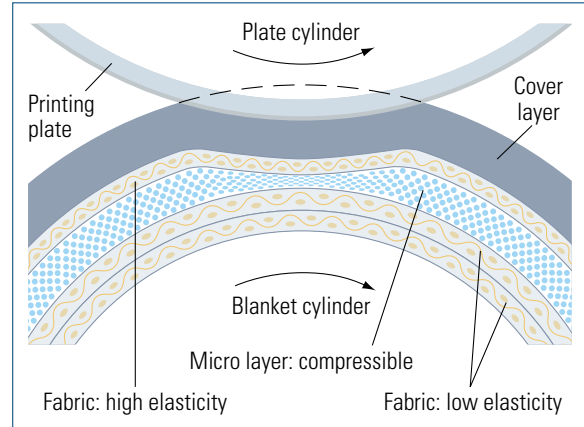


Fig. 2.1-46 Structure of a compressible blanket (ContiTech)

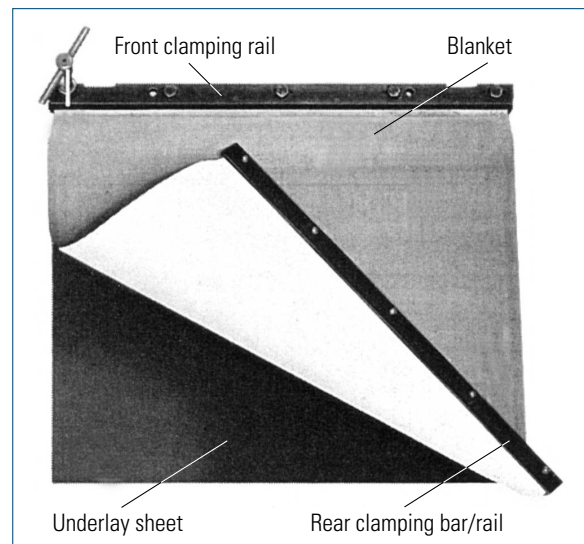


Fig. 2.1-47 Fixing the blanket (pre-railed blanket)

the packing material to balance out minor inaccuracies in thickness and ink transfer.

### Rolling Length

In offset printing the printing or rolling length of the print image in the direction of printing can be shortened by slight amounts in relation to the size of the image on the printing plate by packing the plate (not included in fig. 2.1-45). In multicolor printing, register

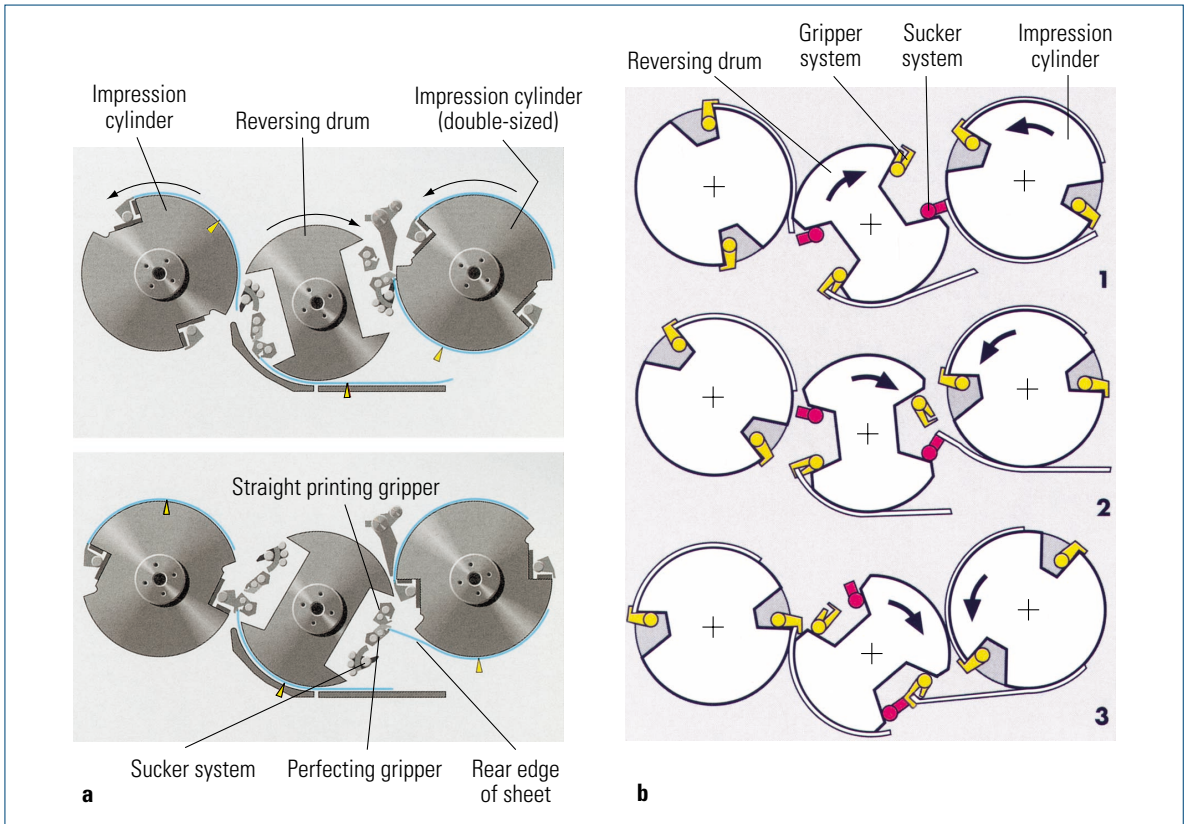
differences may occur, especially if the sheet is subjected to considerable tensile forces. This can be compensated for by printing the first color separation slightly shorter, for which a sheet is placed under the plate in the first printing unit. A 0.1 mm packing under the plate produces an approximately 0.4 mm shorter print image with standard cylinder geometry.

But this contradicts the wish for ever shorter make-ready times. Packing the plate simply takes too long. Especially with short print runs this is no longer practicable. It is more efficient to make allowances for any potential distortion of the paper in the digital prepress stage when producing the film or plate. It is also still perfectly possible to print the first color rather shorter

and to mount the first plate cylinder permanently with the attached packing minimally higher than the next cylinder.

#### 2.1.2.4 Sheet Reversal/Perfecting

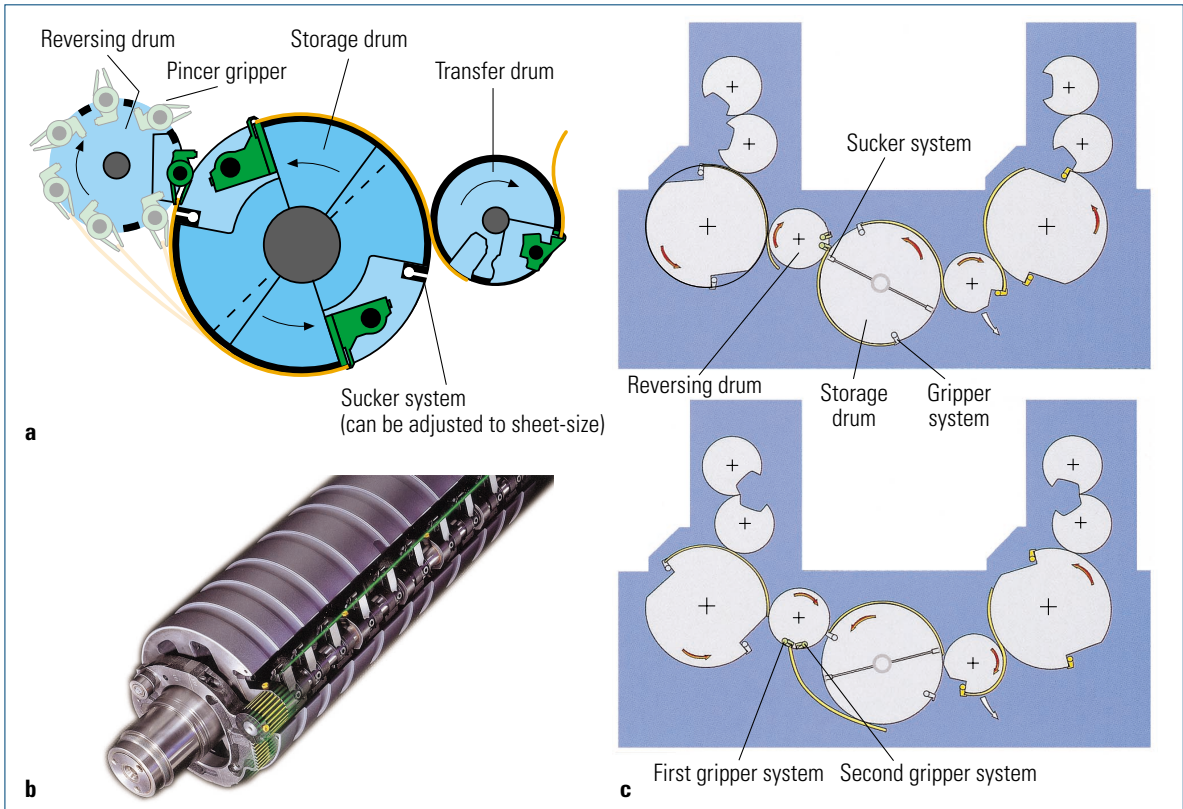
The ability to switch over the sheet travel from straight printing to *perfecting* necessitates a sheet turning device (perfector) between the printing units, where the sheet is reversed (“work and tumble”, see fig. 2.1-32b) at full production speed for printing in-line on both sides of the sheet. These types of presses are called “perfecting presses”. In figures 2.1-48 and 2.1-49 two structurally different sheet reversal designs are illustrated, a “single-drum system” and a “three-drum system”.



**Fig. 2.1-48** Sheet turning devices (single-drum system).

**a** MAN Roland system: The sucker system picks up the rear edge of the sheet, transfers it to the perfecting grippers which then transfer it to the straight printing grippers. The front sheet edge is released first (Roland 700, MAN Roland);

**b** Koenig & Bauer system: The rear sheet edge is gripped by the sucker system of the sheet reversing drum and the front edge is then released. Sucker and gripper system in the sheet reversing drum move towards each other and the sheet is transferred to the grippers (Rapida 72, KBA)



**Fig. 2.1-49** Sheet reversing systems (three-drum system).

**a** Heidelberg system (basic principle): The pincer grippers of the reversing drum take over the sheet at the rear edge in a single gripper closure from the storage drum (Heidelberg);

**b** Reversing drum with pincer grippers controlled via gear wheel and toothed segment (Heidelberg);

**c** Koenig & Bauer system: Suckers in the storage drum grasp the rear edge of the sheet and transfer it to the first gripper system in the sheet reversing drum. This gripper system then transfers the sheet's rear edge, which in the meantime has become the sheet's front edge, to the second gripper system (Rapida 104, KBA)

The sheet is turned in the perfecter by transfer grippers grasping the rear edge of the sheet. After the sheet has been turned, the rear edge of the sheet then becomes the new front edge for the following print on the reverse side. For the sheet assembly of perfecting jobs it is important that there is a gripper margin on the front and the trailing edge of the sheet. A quite considerable simplification and increased productivity on the part of perfecting presses is obtained with this “in-line turning” because the sheet needs to be aligned only once in the press; it is not necessary to re-align the sheet to the second gripper margin after sheet reversal.

On purely straight printing presses, four-sided trimming is usually required for work-and-tumble jobs, to

ensure that all sheets are of exactly the same size for the second sheet pass, or the side guides must be turned and the direction of pull needs to be changed when using the work-and-turn method. On the perfecting unit the sheets are pushed into the grippers in proportion to the length of the individual sheet. In this way the sheet remains properly aligned at the infeed edge.

Striving for a more cost and time-effective print production has led to the development of perfecting presses that allow printing on both sides of a sheet in one pass. It is more cost and time-intensive to run a sheet through the press a second time to print the reverse side than it is to print both sides in a single pass. In the early stages of perfecting technology, perfecting presses

were only able to produce single-color prints on the reverse side. A single ink layer is much easier to monitor than a full-color set. The ink is absorbed into the paper very quickly and virtually without resplitting on subsequent impression cylinders. With single-color perfecting there is hardly any risk of smearing or doubling.

There are special perfecting units for single-color perfecting, as shown in the example in [figure 2.1-50](#). Perfecting can also be done by printing from underneath directly against the transfer cylinder (see [figs. 2.1-74](#) and [2.1-75](#)).

#### 4/4 Printing

On modern presses which can produce four-color prints both on the front and reverse sides in one pass and at the same quality on both sides, the distinction between the side printed first and the one printed last no longer plays a role. Technical developments have made it possible to construct eight-color presses with extremely high sheet travel precision and series-produced special impression cylinder surfaces for perfecting, making it possible to turn the sheet after four colors. In this way 4/4 color prints can be achieved in a single pass. After the sheet reversal the freshly printed inks are pressed against the impression cylinder at full contact pressure when the sheet passes through the subsequent printing units.

Any attempts to solidify the ink enough to prevent any ink splitting have proven to be unsuccessful with all known offset inks other than UV inks used in combination with *inter-unit dryers*. Consequently, the other route has been followed and the inks are kept fluid until the final printing unit. Fresh, resplittable ink has a lower tendency to pile, but the press becomes some-

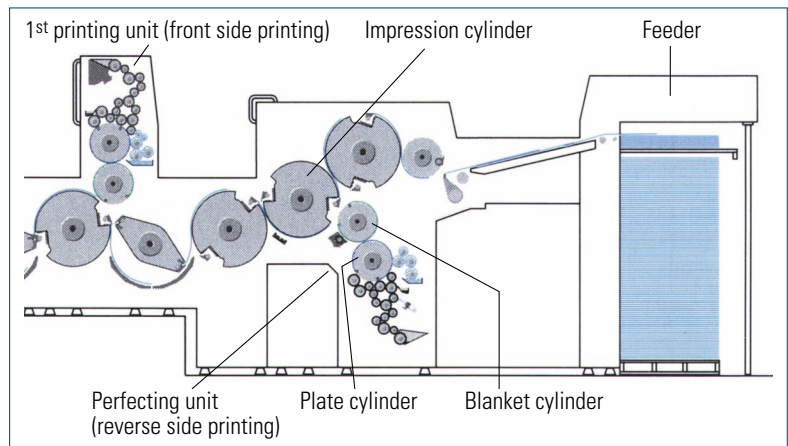
what more prone to doubling if the reversed sheets are not transferred with a great degree of accuracy. Each dot that has been resplit on the impression cylinder must be perfectly superimposed dot by dot on the next sheet. On a 60 lines/cm screen, an offset of only around 10 µm causes doubling that is recognizable to the naked eye as tonal shift.

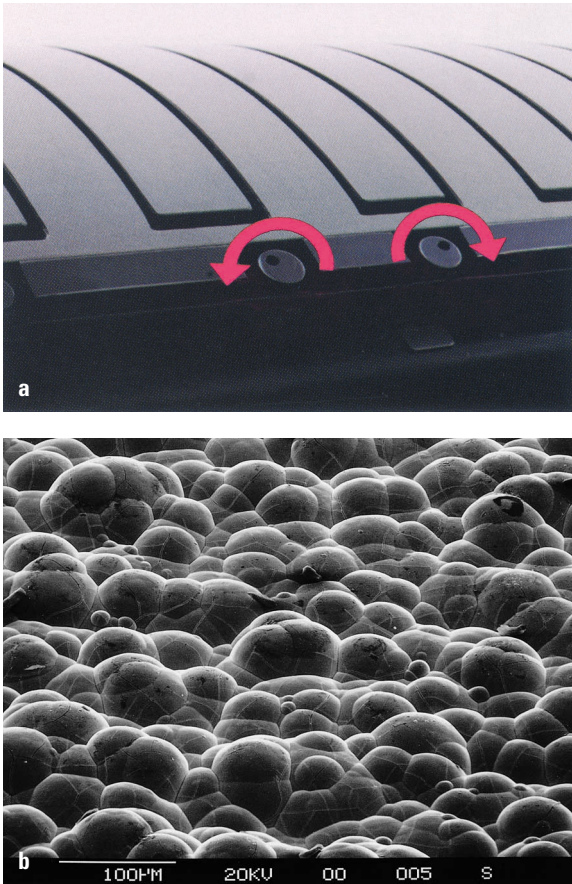
With suitable structural measures it has become possible to guide the sheet smear-free through the press just as accurately after the sheet reversal as is the case with long presses with no perfecting unit. [Figure 2.1-51](#) shows technical details on the design of perfecting presses: [Figure 2.1-51a](#) shows a suction device on the storage drum (see also [fig. 2.1-49a](#)), which keeps the rear sheet edge in position and smoothens the sheet. [Figure 2.1-51b](#) depicts the surface structure of the cylinder jacket fitted on impression cylinders that are arranged after the perfecting unit to prevent smearing of the freshly printed image. Surface coatings such as silicone are also used, where setting off or resplitting of the ink can be prevented merely by physical interfacial processes without the need for any geometrical fine structuring of the surfaces.

Although the inks have to remain fresh on their way though eight printing units, after the final printing unit the inks should dry very quickly. The more the ink has solidified on the sheet, the more likely it is that the sheets can be piled without offsetting. Since these two requirements on the drying behavior represent conflicting characteristics, it is impossible to fulfill them both to the same degree at the same time. Consequently, heavier powdering has to be applied on high-speed eight-color presses than on shorter printing

**Fig. 2.1-50**

Perfecting unit for packaging printing  
(Roland 900, MAN Roland)





**Fig. 2.1-51**

**a** Smoothing of the rear sheet edges by fixing the sheet on the storage drum using rotary suckers (up to 20 for large sheet size);  
**b** Refined impression cylinder surfaces arranged after the sheet reversing unit, specially-chosen material and surface structure to avoid the offsetting of freshly printed ink (Heidelberg)

presses. The trend in press engineering is towards even longer presses (6/6) so that meanwhile additional spot colors can be printed. Coating units are also used to apply an even coating layer over the entire image surface or to do spot coating, and all this is integrated with special drying units in front of and after the sheet reversal.

### Variants in 4/4 Printing

A special structural variant of 4/4 printing is a perfecter that prints the sheet in one pass alternately from above and below (see [figs. 2.1-74](#) and [2.1-75](#)). The impression cylinders of the lower printing units simulta-

neously perform the function of transfer cylinders for the upper printing units. The upper units, on the other hand, print against the transfer cylinders of the lower printing units. As in web offset, four blanket-to-blanket printing units are arranged in a line, and two operating levels are required for the upper and the lower printing units. This results in shorter presses for multicolor printing on both sides, albeit with increased overall height. With this design the sheet does not need to be turned and consequently no second gripper margin is needed. On the other hand, this press does not have the flexibility required for the most diverse color combinations, as is achieved on presses with convertible perfecting units.

In conventional production, eight-color presses are not only used as 4/4 perfectors, but also for 8/o print jobs. To meet exacting demands in quality, decorative/spot colors are printed with a special ink rather than with color mixing with the basic colors of cyan, magenta, yellow, and black. This separation between decorative color and multicolor halftone image enables well-directed control of the respective image sections, which ultimately leads to shorter makeready times.

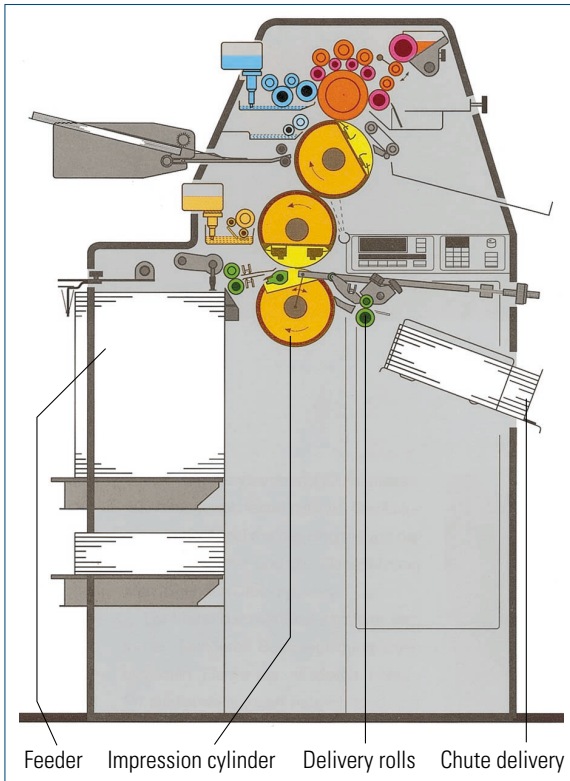
### 2.1.2.5 Delivery

After printing, the sheets are fed to the delivery pile. The simplest technological solution is the *chute delivery* ([fig. 2.1-52](#)), which is used in some small offset presses, where the sheets are transported on the delivery table by rollers.

A straight-edge delivery pile is usually required, where each of the delivered sheets is jogged one by one to produce a neat pile. The deliveries of sheet-fed offset presses are equipped with *sheet joggers*, which take every sheet to the same position on the pile. Exact pile formation is essential to avoid a manual or automated sheet alignment before subsequent finishing operations can be performed.

The standard *chain delivery system* ([fig. 2.1-18](#)) conveys the sheet from the final impression cylinder to the delivery pile. A distinction is made between presses with high-pile delivery ([fig. 2.1-18](#)), standard delivery and extended delivery systems.

The *standard delivery* ([fig. 2.1-21](#)) is the most compact and economical design. The short chain delivery unit carries the sheet directly (generally horizontally) from the impression cylinder to the delivery pile. This means that the pile is only about 50 cm high, depending on the press model. For standard short print runs this delivery pile height (approximately 1000 to 5000 sheets) is usually sufficient.



**Fig. 2.1-52**  
Chute delivery on a small single-color offset press (TOM, Heidelberg)

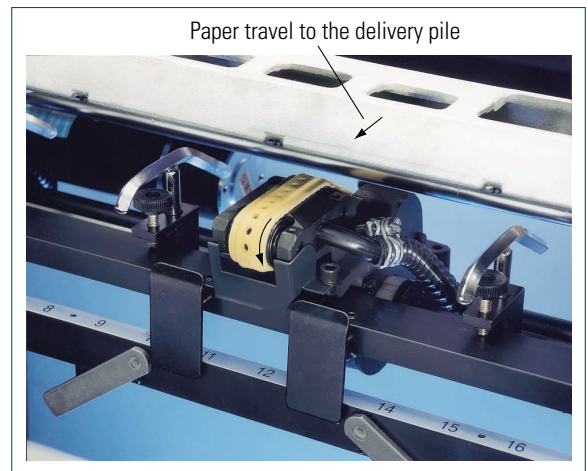
With longer print runs, faster presses, and thicker substrates, the time between pile changes should be as long as possible, therefore *high-pile deliveries* with a *pile height* of more than 1 m are preferred. For papers with grammages of 100 g/m<sup>2</sup> (approximately 0.1 mm thick) this is equivalent to 10 000 sheets, which is usually printed in barely an hour. Cardboard printers tend to raise their presses, so that correspondingly higher piles can be processed in feeder and delivery. In a high-pile delivery (fig. 2.1-18) the sheet travels a correspondingly longer distance from the impression cylinder to the pile.

At fairly high press speeds lightweight sheets tend to flutter, and in the course of this the fresh ink may smear on contact with press elements in the area of the delivery. Turbulences generated by the gripper bars when releasing the sheet induce the sheet fluttering. Aerodynamic tests with the aim of optimizing sheet guidance and installing special *sheet guidance elements* have resulted in smooth sheet guidance. An air current, gener-

ated between the guide plate and the printed sheet (figs. 2.1-18 and 2.1-56a), holds the sheet at a specified distance from the guide plate. This sheet guidance in the delivery is a fundamental constituent of completely smudge-free sheet delivery (see also sec. 13.1.3.4 and fig. 13.1-53).

The distance to the delivery unit can be used to accommodate *drying units* such as IR dryers, UV dryers, hot air blowers, air circulating blowers, or *powder spraying devices* and extraction systems. This space is often not adequate to accommodate all units, in which case an *extended delivery unit* (figs. 2.1-57 and 1.7-2) may be necessary for the installation of dryers. An extended delivery unit has the additional advantage of allowing more time for the ink to solidify without any special drying equipment. On high-speed presses in particular, the time between the final printing unit and the delivery pile is very short, in the region of less than one second. Time extensions of almost a second can bring the solidification of the ink or vanish application into a range in which offsetting is avoided, or the necessary powder application can be reduced.

Since the sheet arrives in the delivery at high speed, it is necessary to slow down the sheets using braking systems. The gripper opening cams can be adjusted so that the grippers are already open a certain distance before reaching the end of the pile. At this same moment the rear sheet edge is drawn in from below by *braking suction rollers or belts* (figs. 2.1-53 and 2.1-21). The sheet arrives with so much kinetic energy that it would normally continue to travel. The braking rollers, with a cir-



**Abb. 2.1-53**  
Sheet slow-down device (Speedmaster SM 74, Heidelberg)

cumferential speed lower than the printing speed, hold the sheet firmly at the rear sheet edge and stretch it, so that the sheet is laid out virtually flat.

In *convertible perfecting presses* the underside of the sheet is also covered with fresh ink, so the braking rollers must be positioned only on non-image areas. Sufficiently wide non-image areas can often be found between the trim of the individual pages printed on a sheet (e.g., eight pages on one side of the printed sheet). Generally speaking, however, with 4/4 print jobs, possible traces of the braking rollers should also be taken into account in the sheet layout.

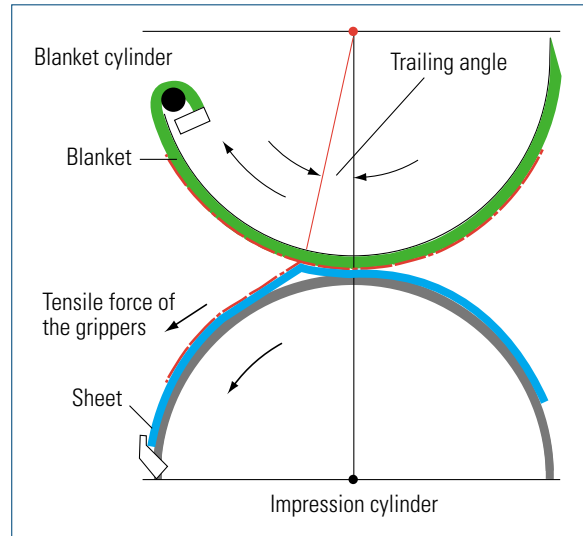
The flatter the sheet lies in the delivery, the better the air cushion between the sheets will be maintained, and the more evenly the contact pressure in the pile will be distributed over the surface of the printed sheet. All these things help to avoid the risk of ink offsetting.

To achieve a satisfactory and sufficiently fast delivery, the dropping down of the sheets is *supported by blowers* located between the top and bottom chain guides (see [fig. 2.1-21](#)). The *blast air* must be regulated according to the paper quality, grammage, sheet size, direction of travel, and printing speed in order to achieve an optimal effect. The sheet should show (in its direction of run) a slight downward bend at its center, so that the air between sheet and pile can escape at the sides and the sheet remains stable in the direction of travel. A sheet-fed offset press in the 70 cm × 100 cm format class (see also [fig. 2.1-64](#)), is equipped with fifteen fans above the delivery pile (in the direction of travel, three rows of five fans). The blowing power of these fans is adjustable in several zones.

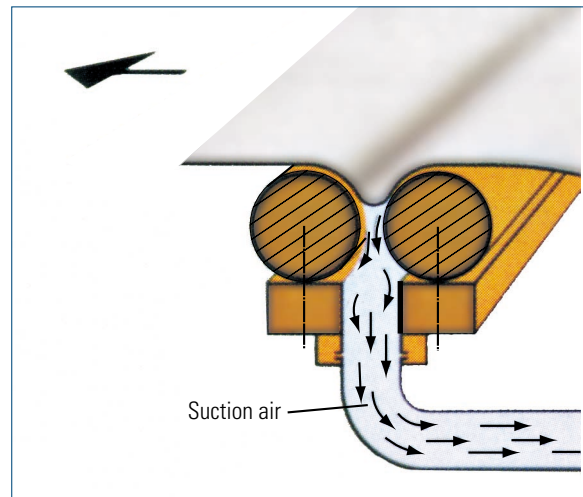
Sheets printed on one side often have such a strong tendency to curl in the delivery pile that it is difficult to form a smooth pile. This *curl formation* in the paper also increases the risk of offsetting and blocking (freshly printed sheets sticking together). Curl formation is encouraged by the rheology of offset inks: the sheet sticks to the blanket so firmly that the grippers have to remove the sheet with a great deal of pulling force. The paper stretches somewhat in the course of this action, and is rotated on the blanket cylinder at a certain arc. When the sheet is released from the blanket a slight bending radius is produced ([fig. 2.1-54](#)). The *sheet decurlers* ([figs. 2.1-55](#) and [2.1-21](#)) in the delivery area bend the sheet in the opposite direction, so that a good flat position is regained. (The sheet decurler is not needed for perfecting jobs.)

### Powder Application

In sheet-fed offset, the conventional ink is still not thoroughly dry when the sheet arrives at the delivery pile.



**Fig. 2.1-54** Releasing the sheet from the blanket (trailing effect)



**Fig. 2.1-55** Sheet decurler

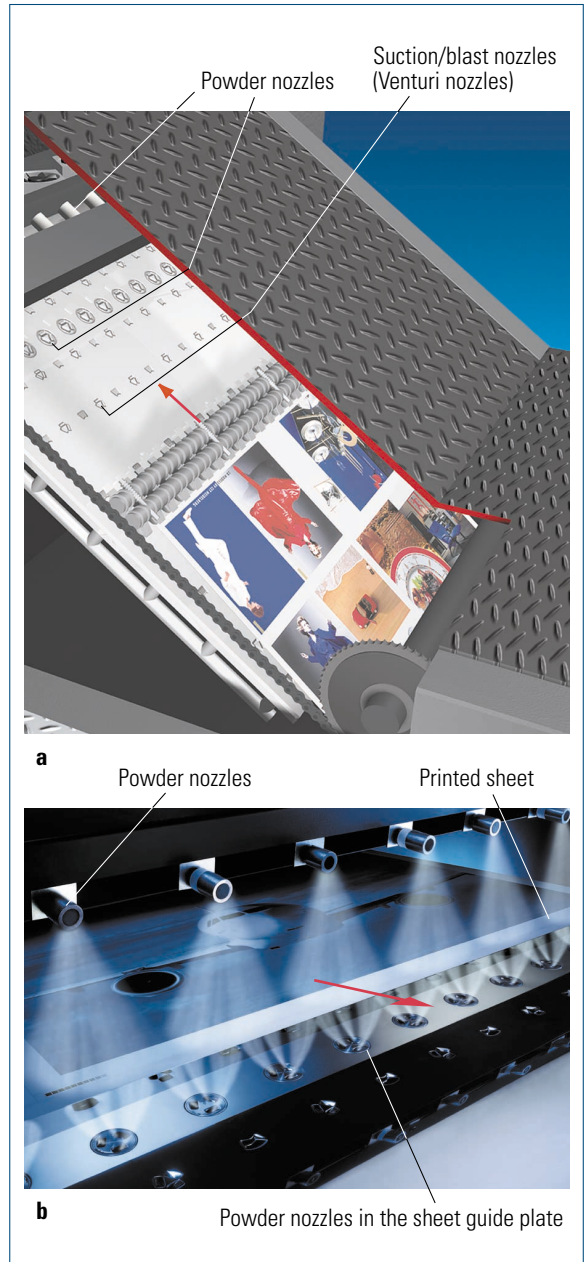
Consequently one of the major requirements in sheet-fed offset is the avoidance of *smearing*, *offsetting* (transfer of ink onto the following sheet), and *blocking* in the pile (sheets lying on top of each other sticking together). The application of powder offers a remedy ([fig. 2.1-22](#) and [sec. 1.7.3.1](#)) yet brings many negative consequences, such as soiling of the press, quality defects in the print area (reduced gloss), and finishing problems.

Due to the powder layer between the sheets, the wet ink surface does not come in contact with the following sheet. Only a small proportion of the delivered powder actually arrives on the sheet. The faster the press runs, the smaller the powder yield that actually reaches the sheet, the remainder contributing to soiling of the press in the delivery area. The longer the press, such as an eight-color press for straight printing and perfecting (4/4), the longer the ink has to remain fresh to avoid build-up on the impression cylinders, and the more crucial the pile formation in the delivery becomes. Consequently, with long, fast-running sheet-fed presses, powdering has to be intensified. Powder extraction systems in the delivery actually remove large quantities of powder, though a residue still remains, which necessitates cleaning work in the press, though considerably less often.

*Both-sided powder spraying* (fig. 2.1-56) from above and below brings obvious savings in the quantities of powder used. The major saving is made with verso powder spraying. The gripper bars carrying the sheet into the delivery are shaped so that the sheet is guided on an air cushion at a minimal distance above the guide plates (fig. 2.1-56a). Due to the small distance between the substrate and the powder outlet nozzles in the guide plates very little powder is lost, so the powder metering is very effective and powder can be reduced accordingly. Conventional top powder outlet nozzles are at a much greater distance from the sheet on account of the gripper bars, and so the air eddies behind the gripper bar swirl up the powder stream and the powdering is ultimately much more liberal in order to compensate for losses (see also fig. 2.1-59). For virtually all print jobs it is adequate to powder sparingly from the rear side, even if it has not been printed on.

Another way of optimizing the sheet's behavior in the delivery pile lies in improving the drying process by accelerated absorption (see sec. 1.7.1). Absorption can be accelerated using *IR drying* if the ink and paper are well-matched to one another.

Another option for optimizing delivery behavior (together with improvement of the print image quality/the image appearance) is the *application of varnish* (see sec. 2.1.2.7). Water-based dispersion varnish dries so quickly that powdering can, to a large extent, be dispensed with. Nevertheless, dispersion varnish is only used to improve delivery in exceptional cases, since a separate printing unit has to be incorporated for its application. The increased use of water-based dispersion varnish would improve gloss, give increased protection from abrasion and also improve delivery behavior.



**Fig. 2.1-56** Powder application in the delivery area.

- a** Sheet guide and powder application;
- b** Powder spraying on both sides (Heidelberg)



### 2.1.2.6 Drying

The drying processes possible in sheet-fed offset, such as

- IR drying,
- hot-air drying, and
- UV drying/curing

are described in detail in [section 1.7](#) and therefore only a few specific designs and special features in sheet-fed offset will be dealt with in this section.

The following two requirements are of particular importance in multicolor sheet-fed offset:

- Drying in the delivery pile after printing should be done as quickly as possible so that the printed sheets can be finished without delay.
- The drying of the ink on the printed sheet between the printing units must guarantee sufficiently good ink acceptance in the subsequent printing unit so that doubling, color shifting over the print run, and/or soiling are avoided.

#### IR and Hot-air Drying

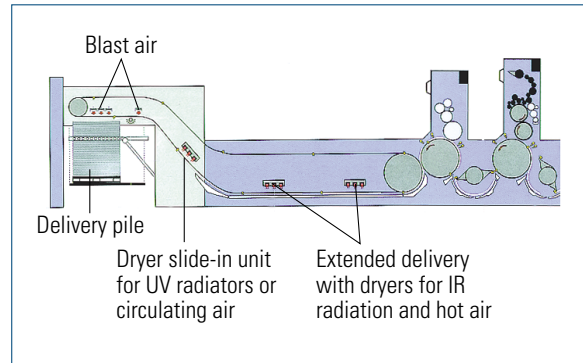
The ink is usually chosen and possibly modified by the printer on the basis of its drying characteristics on the paper quality to be printed on, the technical process-related requirements, and the desired print quality. There are different drying systems available to enable optimal drying of a great variety of inks:

- *IR dryers* accelerate absorption and oxidation (cross-linking) of the ink.
- *Hot-air dryers* with ambient air blowers provide a higher exchange of air and, as a result, they vaporize the water (dampening solution) contained in the ink and paper faster. Hot-air dryers are also particularly effective in the drying of water-based dispersion varnishes.

Additional ambient air blowers with cold or warm air may be expedient for better drying and for “gentle treatment” (waviness, drying-out) of the paper.

Present-day sheet-fed offset presses for multicolor printing are also available with *extended delivery*, into which the most varied dryer modules can be fitted. [Figures 2.1-57](#), [2.1-64](#), [2.1-22](#), [1.7-2](#), and [1.7-10](#) show examples of modular dryer installation.

Particularly efficient is a dryer design featuring a *combination* of IR radiator and integrated hot-air

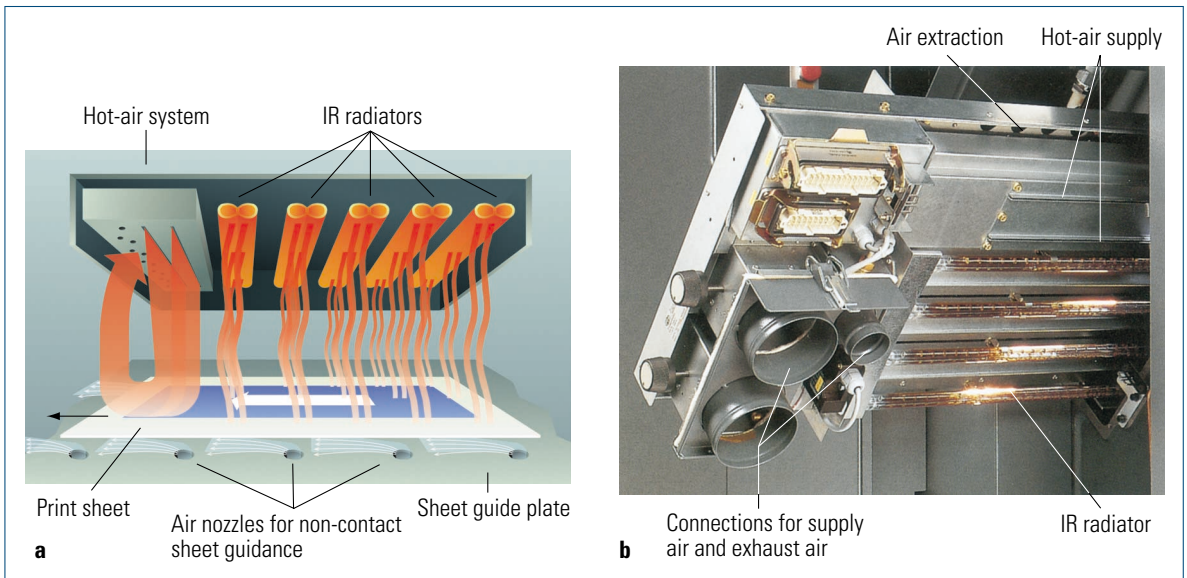


**Fig. 2.1-57** Extended chain delivery with dryers (KBA)

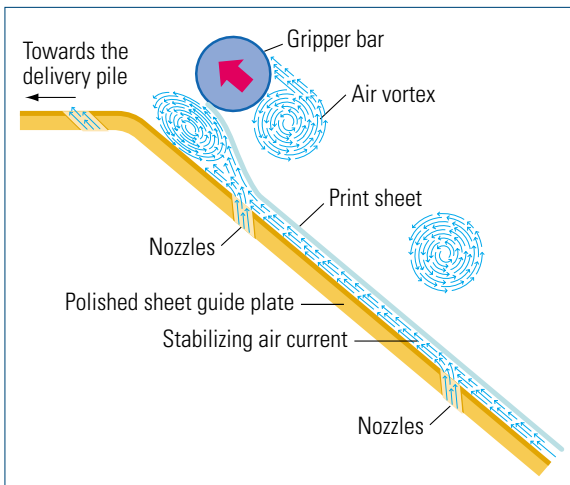
blower as illustrated below in [figures 2.1-22](#) and [2.1-58](#). The sheet is stabilized (no fluttering of the sheet) by means of the sheet guide plate fitted with specially formed air nozzles (venturi nozzles) and held at an optimal and safe distance from the radiators ([figs. 2.1-56a](#) and [2.1-59](#)). The floatation guidance is of great benefit, especially for sheets with print on both sides, in avoiding damage (scratches) on the print as a result of the surrounding components.

Another special feature of this dryer is the fact that the IR radiators are cooled/temperature stabilized by blast air fed to the radiator on both sides by fine nozzles. Flow detectors monitor the air current, ensuring that the radiators are quickly up to operating temperature when they are turned on, and that overheating during operation is signaled immediately and the radiator power reduced as necessary. If only fairly small format printing is being done, the width of the radiator can be reduced by the removal or addition of IR radiator components, as illustrated in [figure 2.1-60](#).

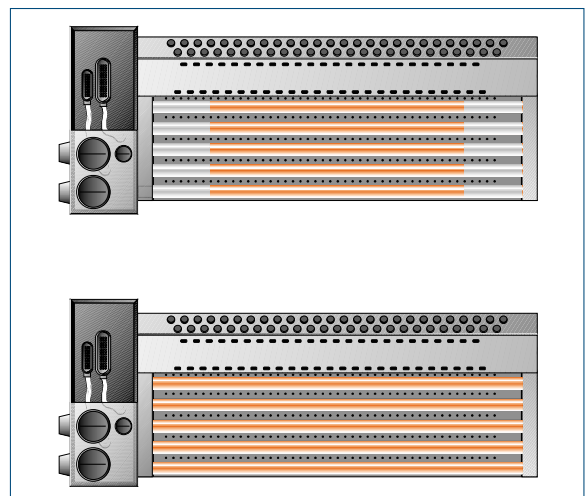
Both chemical and physical balance reactions can be accelerated by heat radiation in the infrared range. However, the drying period required before it is possible to finish the sheets will still be several hours, depending on process conditions. Both oxidative drying and drying by absorption proceed faster at increased temperatures than at ambient temperature. Absorption is an exponentially convergent diffusion/equalization process. The warmer the substrate surface, the faster the final balanced situation is reached. The higher the ink absorption ratio during the drying process, the greater the contribution the heat radiation makes to the improvement in delivery and pile behavior.



**Fig. 2.1-58** Dryer module for the combination of IR radiation and hot air.  
**a** Diagram of the drying module: Non-contact guidance of the sheets in the delivery;  
**b** Combined dryer (Drystar, Heidelberg)



**Fig. 2.1-59**  
 Stabilization of the sheet by special air guidance, venturi nozzles in the sheet guide plate



**Fig. 2.1-60**  
 Adapting the radiation width to the print format (Drystar, Heidelberg)

The piles can be run higher without the fear of blocking (sheets sticking together).

Oxidative cross-linking of the ink film is also accelerated under the influence of heat, as well as

absorption. Compared to cross-linking under UV radiation, oxidative processes proceed slowly. The drying period of usually several hours (depending on the paper and ink, from five to twenty hours with-

out special drying measures) can quite easily be halved.

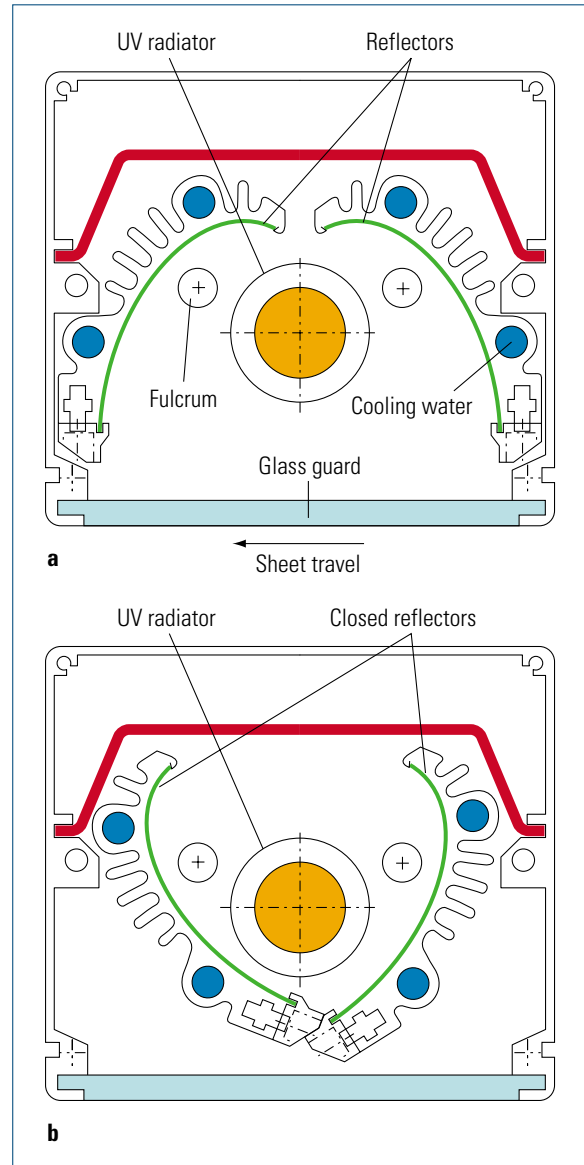
Drying by the application of heat between the printing units (inter-unit drying) would lead to poorer ink splitting in most cases and is therefore only rarely used. The absorption of the oleaginous constituents of the ink into the paper between printing units at ambient temperature is sufficient for good absorption of the next ink film. In perfecting, as already described, attempts are even made to keep the ink film fresh on the substrate until the final printing unit, to ensure ink splitting on the second side when printing the first side and thereby avoid ink build-up on the impression cylinder. Therefore there is no point in introducing inter-unit drying.

To minimize the problem of ink resplitting from the previous to the subsequent printing unit, it is also possible to adapt the rheology of the ink, and here in particular to graduate the tack of the inks accordingly (higher tack in the preceding printing unit).

### UV Drying

A reactive binder/vehicle system will be cured in a very short time (almost instantaneously) under the influence of UV radiation. In sheet-fed offset, the use of radical inking systems predominates and mercury gas discharge lamps with an output of 100 to 120 W per cm printing width are usually used for drying. Since the UV radiator converts only approximately 25% of the consumed power into UV light (the balance is almost 50% in IR radiation and 25% in visible radiation), the radiators become very hot and have to be adequately cooled over the housing and the reflector (see also [sec. 1.7.2.2](#)). The thermal load of the substrate is considerable, and it increases with substrate thinness – that is to say, with reduced thermal capacity. To prevent the sheet from touching the radiator and becoming overheated, for example during a paper jam, the UV dryers are equipped with safety devices such as closable reflectors ([fig. 2.1-61](#)).

UV dryers can be used both in the delivery after wet-on-wet printing and also for *inter-unit drying* (drying between printing units). In wet-on-wet printing the tack of the UV inks is adapted by the ink manufacturer according to their sequence during printing. This is also usually the case with oil-based inks. Printing with UV inks is often done in conjunction with very high requirements on print quality and special printing features. To be able to fulfill these requirements, multi-color presses are more often than not equipped with in-



**Fig. 2.1-61** UV dryer with shutable reflectors.

- a** Open reflector;
- b** Closed reflector (Dr. Hönle)

ter-unit drying (see [fig. 1.7-10](#)). Inter-unit drying must be done if the layers of ink are extremely thick, to improve ink acceptance and gloss. A thick and evenly printed ink film is then dried before another color is applied in the next printing unit (e.g., black type on a silver background).

As already described, mercury gas lamps, with the disadvantage of high proportions of IR radiation as well as ozone formation, are usually used in sheet-fed offset. Drying devices with excimer radiators (see sec. 1.7.2.2), which do not suffer from this disadvantage, are under development for sheet-fed offset. These radiators are (still) limited with respect to output, so inert gas (nitrogen) has to be used between sheet and radiator to support initialization. Using a chamber filled with nitrogen, as is the case with web presses, is virtually impossible in sheet-fed offset presses on account of the gripper bar that would have to be used. Much of the nitrogen is carried off without being used.

### 2.1.2.7 Print Enhancement and In-line Finishing

Print Enhancement and in-line finishing processes are widely used in sheet-fed offset, the following being the fundamental processes:

- *coating* to improve the visual impression and/or to protect the printed surface;
- special additional printing with *metallic inks*;
- *numbering* and simple *imprints*;
- *surface treatment*, such as perforation and punching, cutting, creasing and embossing.

#### Print Enhancement/Surface Finishing

It is mainly coating units that are used today for *coating* or the application of metallic inks (fig. 2.1-62). However, some varnishes can also be applied using standard printing units (e.g., water-pan varnish via coated offset plates).

Coating units should always be considered as a system operating in combination with a dryer (hot-air, IR, UV). The demands on surface finishing determine the nature and characteristics of the varnish to be used and the type of drying. In sheet-fed offset, dispersion varnishes (water-based varnishes) and UV cured varnishes predominate. Oil-based varnishes are rarely used because they produce very little gloss. Very glossy surfaces are achieved with both dispersion and UV varnishes. Annual reports, brochures, catalogues, wine labels, cosmetics and food packaging are typical products. Special effects can be achieved with metallic varnishes such as gold and silver.

Besides enhancing the product, coating has the positive effect that printing can be done with reduced quantities of powder, therefore the delivery and subsequent finishing machines become less soiled. The composition and properties of varnishes are explained in sec. 1.5.3.

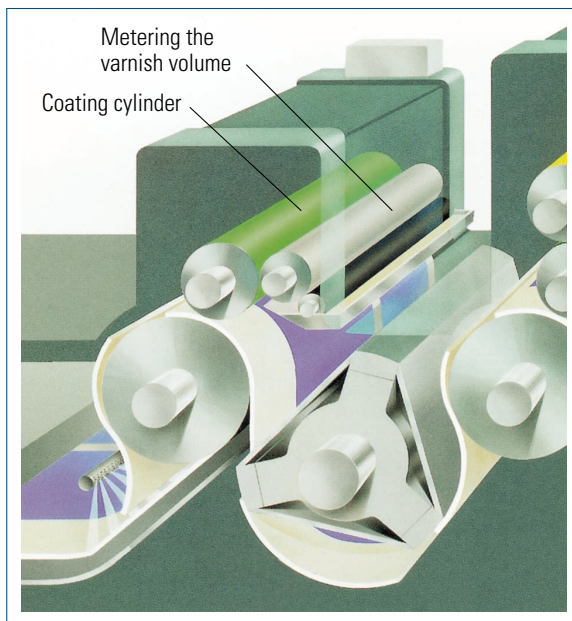


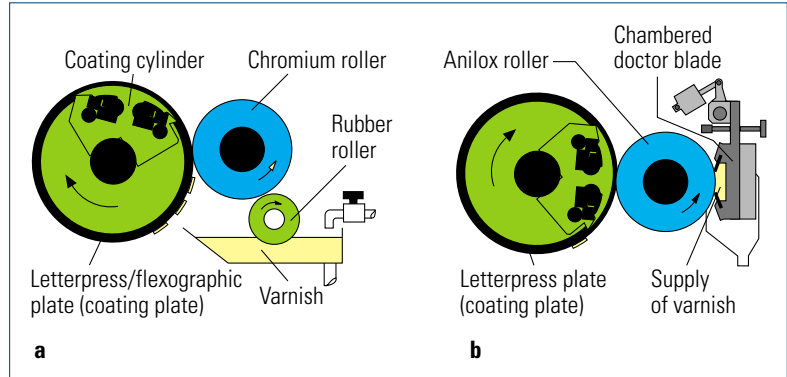
Fig. 2.1-62 Coating unit (Speedmaster 102, Heidelberg)

*Coating units* are very similar to flexographic printing units: a soft image carrier, in its simplest form a blanket for full-surface coating, is “inked” by a hard application roller and the varnish is transferred directly onto the substrate. Two types of systems (fig. 2.1-63) are used for applying the varnish (“inking unit”):

- *Roller system.* The varnish is scooped from a pan by a roller. The coating is metered by a second roller acting as a squeeze roller or by using differential speeds. The quantity of varnish can be varied. Two or three rollers may be needed, depending on the configuration and the direction of rotation.
- *Chambered-type doctor blade system.* The varnish is applied and metered to an anilox roller by means of a chambered doctor blade. A better, more even application of coating can be achieved with this system throughout the print run even at varying production speeds. The quantity of varnish applied depends on the total volume the anilox roller can hold (cell depth, number of cells/cm), that is, the anilox roller has to be changed if the requirements on the coating film thickness change. (A standard value for the total volume of an anilox roller for coating application is  $20 \text{ cm}^3/\text{m}^2$ , which produces a solid coating application of about  $8 \mu\text{m}$ ,  $8 \text{ g}/\text{m}^2$  on

Fig. 2.1-63

Varnish application and metering systems.  
**a** Open system with metering roller (roller system);  
**b** Closed system with chambered doctor blade and anilox roller (Heidelberg)



the substrate.) In practice, it is usually enough to have two to three anilox rollers with different cell volumes, which can be used alternately.

The *printing plates* (coating plates) may consist of:

- blanket for full-surface application of varnish,
- letterpress image carrier (see sec. 1.3.1) made from cut-to-size blanket or strip plates for spot coating (polyester/rubber),
- letterpress/flexographic printing plate (photopolymer with polyester, or an aluminum base due to the greater dimensional stability) for high-quality spot coating or for printing with high-gloss metallic varnishes.

There are quick-action clamping systems available for clamping the coating plate, and the plate cylinder is adjustable in circumferential and lateral direction for positioning the plate in accurate register.

To apply thick layers of dispersion varnish, in conjunction with very high gloss, *double coating units* with inter-unit drying must be used (fig. 2.1-64). The first application of coating seals the surface of the paper, so that after the second application in the second coating unit the varnish can be distributed evenly, resulting in a high-gloss film of coating.

Double coating units are also required to achieve the best results when using UV varnishes. A *primer* is applied as the first coat (mostly an aqueous varnish) and then dried. Only on this base coat will the actual UV coating produce the desired quality.

**Special Effects.** Certain effects can be achieved with varnish that are not possible with conventional offset printing. Printing with gold and metallic pastes can be done in offset printing using conventional methods, but the quality suffers as a result of the low coating thickness to be applied and as a result of the dampening solution and the additives. Better *metallic effects* are

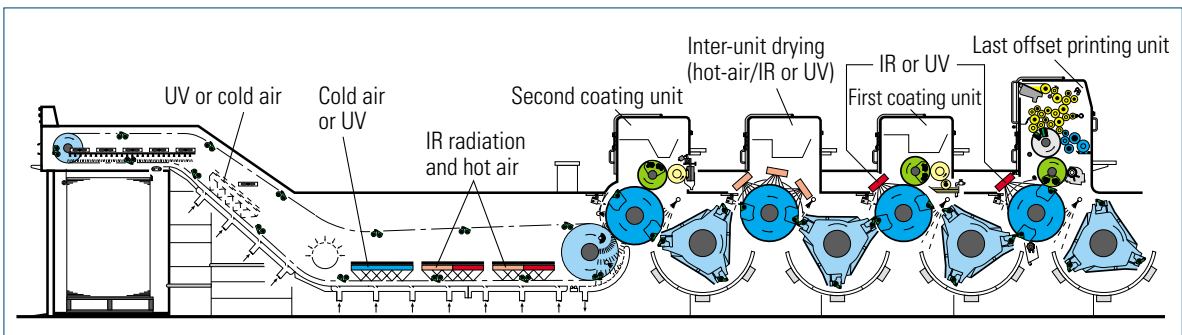


Fig. 2.1-64 Double coating units with inter-unit drying and extended delivery with several dryers (Speedmaster SM 102 CD, Heidelberg)

achieved by using a coating unit. Gloss effects can be achieved with gold and metal pigment inks in conjunction with aqueous varnishes, which are markedly better than those achieved with oil-based inks. Special effects, for instance, gold effects, of a good quality can be created with pearlescent pigments (“metal-free” gold). Another variant for creating special effects with varnish is to apply scents using scented varnish. *Scents*, microencapsulated in the varnish, can be printed on the substrate via the coating unit. The scent takes effect as soon as the capsules are broken open by rubbing.

There are special enhancement machines in use, particularly for coating sheets that have already been printed and whose ink has dried. **Figure 2.1-65** shows an example of such a machine. It is designed for high-quality products yet at the same time offers great versatility in terms of the types of varnishes that can be used. UV varnishes (gloss and matte), dispersion varnishes (likewise gloss and matte), combinations of both varnishes, and also combinations in conjunction with metallic varnishes are possible and ensure a wide range of applications for this machine. The prerequisites, in addition to the universally applicable coating units with a doctor blade, are smudge-free (virtually contact-free) sheet conveyance as well as inter-unit and final drying units. The type of drying, the number of drying processes (dryers), and the drying time can be optimally adapted to the qualities of the substrate and the varnishes used.

### In-line Finishing

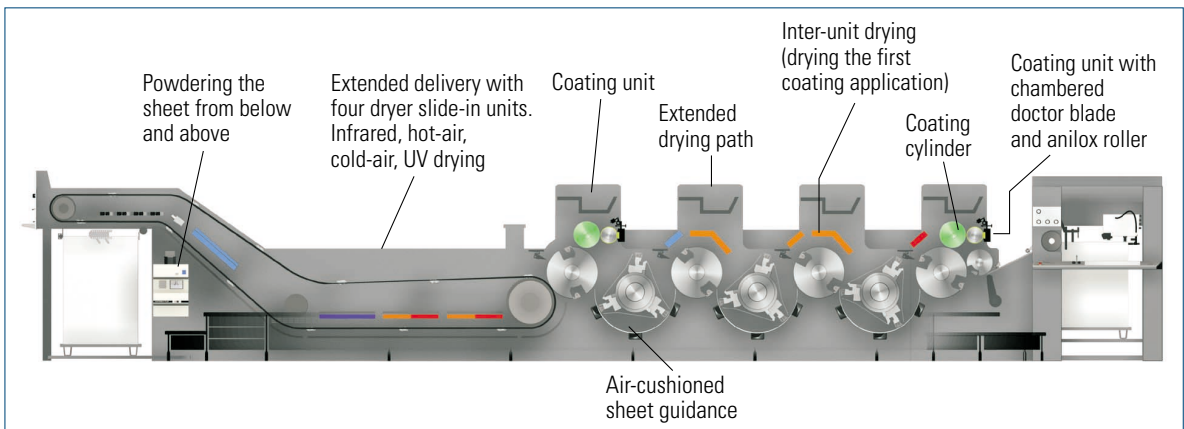
**Numbering, Imprinting.** Many sheet-fed offset presses are equipped for the installation of special number-

ing boxes. **Figure 2.1-66** shows the place of installation and an example of a numbering box shaft with mounted numbering boxes. The numbers are inked by a simple inking unit (letterpress process) and are then printed on the sheet at the final impression cylinder before the sheet is taken over by the chain gripper system. The numbers are indexed with each revolution of the cylinder, mostly by mechanical means. Letterpress plates can be mounted instead of numbering boxes to imprint logos, for example. Depending on the application, a hard or soft packing (sheet metal, cork, plastic film, etc.) must be mounted on the cylinder to protect the surface of the impression cylinder and to achieve the appropriate counter-pressure.

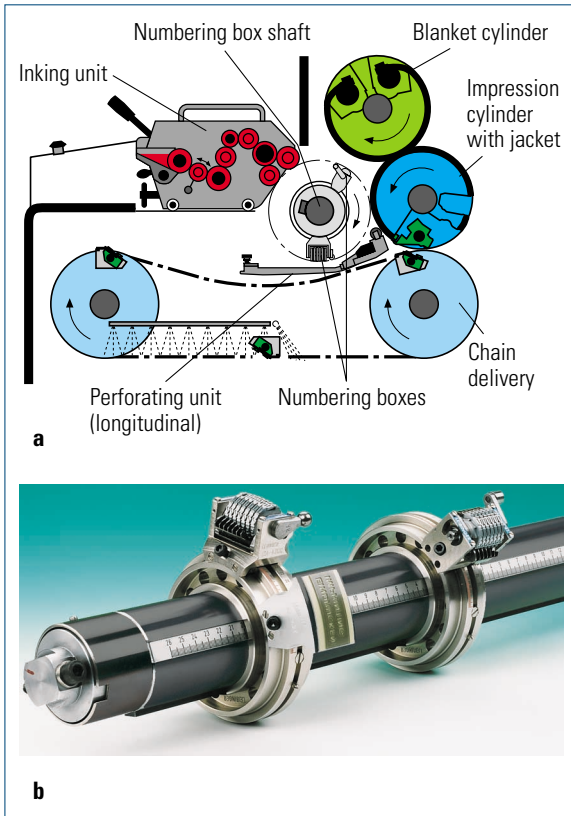
### Perforation, Cutting, Punching, Creasing, Embossing.

The perforating, cutting, creasing, or embossing tools can be attached to a cross bar with millimeter graduations for easier positioning (**figs. 2.1-67a** and **2.1-66a**). As is the case with numbering units, these tools, for instance, slitting wheels, work on the impression cylinder, which therefore has to be equipped with the special cylinder jacket. Perforation, creasing, and so forth, can usually only be done in the sheet’s direction of travel and not at right angles to it. It must also be taken into account that the tools can only be fitted in the areas between the grippers. A device for cross perforation is shown in **figure 2.1-67b**.

So-called “perfostrips” offer another easy method of perforation and cutting. These strips with integrated blades are exactly fixed onto the impression cylinder or cylinder jacket and cut the sheet from underneath



**Fig. 2.1-65** Off-line surface finishing system (Speedmaster CD 102 LYLL, Heidelberg)



**Fig. 2.1-66** Numbering unit.

- a** Numbering box in a single-color press;  
**b** Numbering box shaft with longitudinal and transverse numbering boxes (Speedmaster SM 52-1, Heidelberg)

against the blanket. With this configuration, printing and perforation/cutting can be done simultaneously in the printing unit, although the possibility of damage to the blanket cannot be ruled out.

The sheet can be perforated, cut, creased, or embossed lengthways or at right angles to its direction of travel with specially shaped metal sheets (fig. 2.1-68). These sheets are mounted either in place of the blanket or the cylinder jacket on the impression cylinder. The respective impression cylinder must be fitted with the appropriate cylinder jacket (soft or hard). The diameters are usually adjusted by means of plastic underlays. These metal sheets are used to pre-punch adhesive labels or decals. Cartons are grooved and sheets are cut into strips in this way. It is also possible to produce embossed textures.



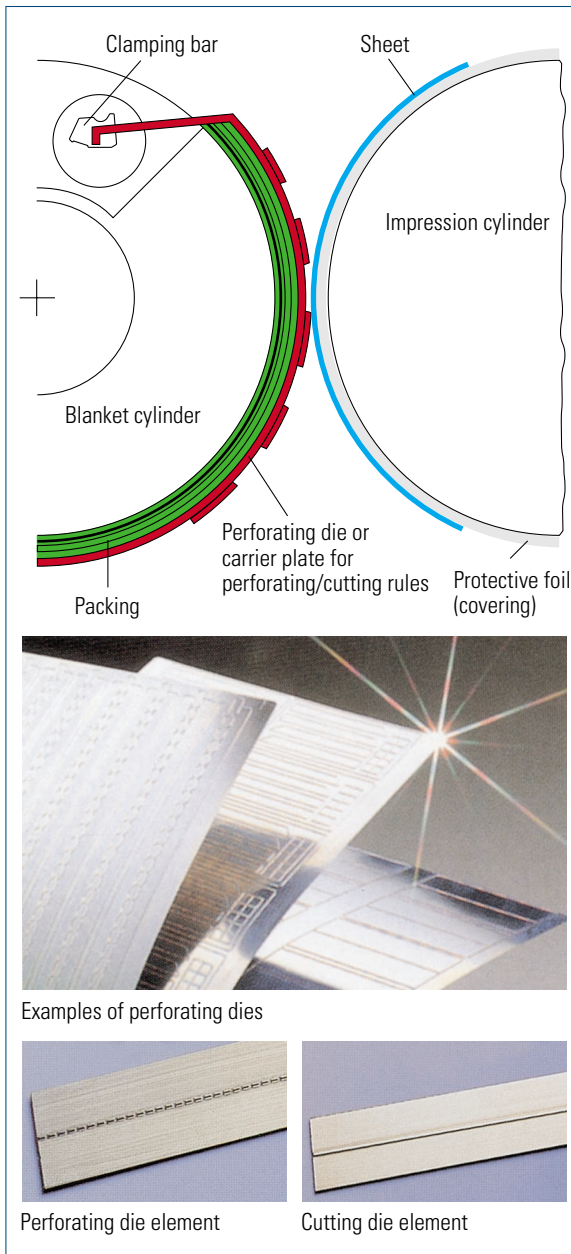
**Fig. 2.1-67** Perforating tools.

- a** Perforating wheel (longitudinal direction);  
**b** Perforating knife (at a right angle to the direction of travel)

### 2.1.2.8 Press Architecture (Special Designs)

#### Non-stop Sheet Feeder

The supply and removal of paper in sheet-fed presses are of crucial importance for productivity and a uniformly high print quality, especially if there is a high throughput of materials. Equipment for non-stop pile change, that is, where the piles are changed without machine stoppages and therefore no new start-up



**Fig. 2.1-68**

Perforating plate for use on the blanket cylinder with perforating and cutting rules to be fitted on the base plate (Perf Print Plus)

waste is created, are essential for a smooth production flow. [Figure 2.1-69](#) (see also [fig. 2.1-161](#) and [sec. 8.1.1.5](#)) shows a device for automatic changing of the pile at the feeder and [figure 2.1-70](#) shows the different stages involved in the pile change.

The pile of paper lies on special pallets that have longitudinal grooves (in the direction of travel of the sheet). Once the height of the residual pile reaches approximately 300–500 sheets, a rake is pushed automatically into the grooves beneath the paper pile ([fig. 2.1-70a](#)). The rake takes over the pile (residual pile) at full printing speed, the empty pallet is lowered and moved away from the feeder area. A new pallet is transported to the exact insertion position by means of special logistics systems and lifted up. As soon as the new pile is underneath the rake ([fig. 2.1-70b](#)), the latter is withdrawn and moved up into parking position ([fig. 2.1-69](#)). This rake method can be applied accordingly in the delivery.

### Non-stop Delivery

[Figure 2.1-71](#) shows another solution for holding the residual or auxiliary pile when changing the pile in the delivery. The printed sheets are deposited on non-stop rollers, while the main pile is lowered and removed from the delivery. An empty pallet is inserted and the rollers retract as soon as the pallet is beneath the rollers.

[Figure 2.1-72](#) shows a press where two delivery locations are arranged one after the other in the chain delivery. The second delivery can be used for pile changes or for stacking waste sheets.

### Waste Diverter

In [figure 2.1-72](#) an image inspection unit can be seen between the delivery and the final printing unit, which detects faults in the print image during production. The fault is signaled to the operator, or the waste sheet is directly diverted to the waste sheet pile.

### Sheeter

A reel-to-sheet device (sheeter) is used instead of a feed pile as shown in [figure 2.1-73](#). There are two advantages of this device. Firstly a considerably larger amount of printing material can be stored at the feeder, and secondly the reel material is less expensive. The web is cut into sheets, which are then fed to the feed table board in a sheet stream.

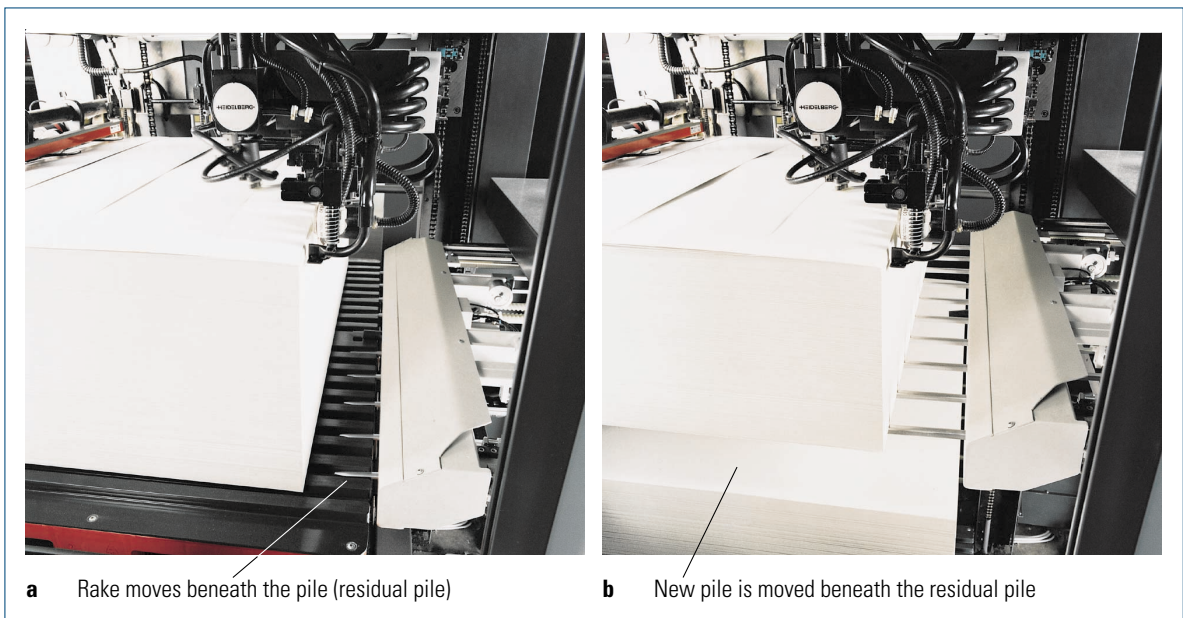
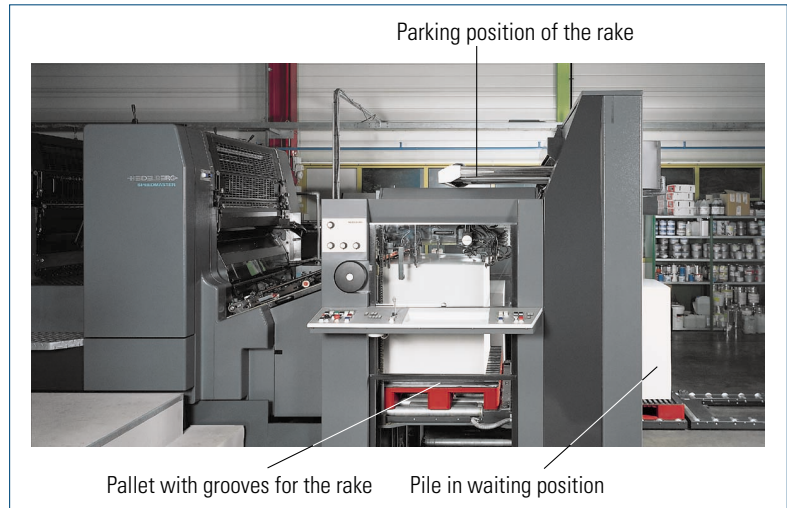
### Straight Printing and Perfecting

[Figures 2.1-74](#) and [2.1-75](#) show two 4/4 perfecter presses on which the printing units are not all arranged in a line



**Fig. 2.1-69**

Non-stop pile change at the feeder  
(Heidelberg)

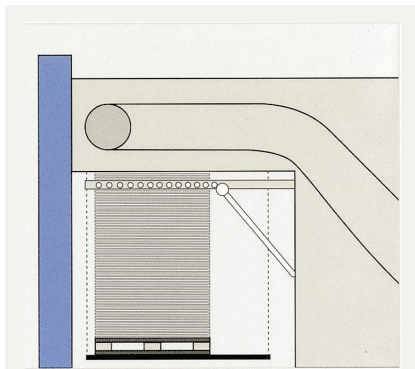
**Fig. 2.1-70** Stages during pile change with a rake.

**a** The rake is moved under the residual pile;

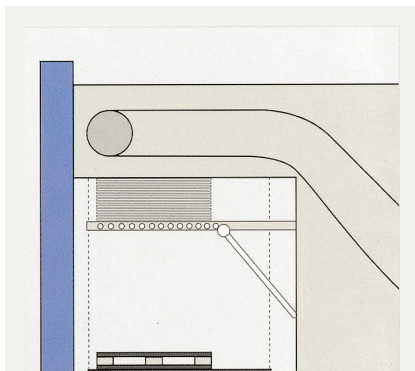
**b** The new pile is moved up to the rake beneath the residual pile, the pile is aligned and the rake is removed (Heidelberg)

but also on top of each other. The sheet is printed alternately from above and below in multicolor. These types of presses are of a more compact design compared to presses with printing units arranged in a line and equipped with a sheet reversing unit, yet the printing

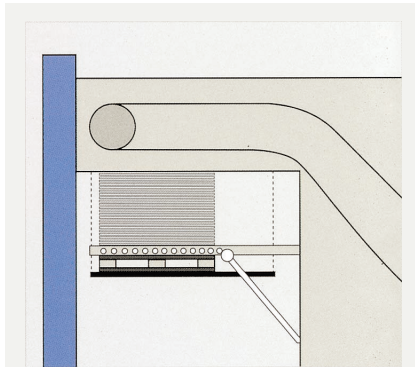
units are somewhat less easily accessible and the press is less versatile (e.g., 6/o or 8/o is not possible). The press in [figure 2.1-74](#) is equipped with single-revolution cylinders and three transfer drums, one of which acts as an impression cylinder for the perfecter. [Figure 2.1-75](#)



The inserted rollers take on the sheet

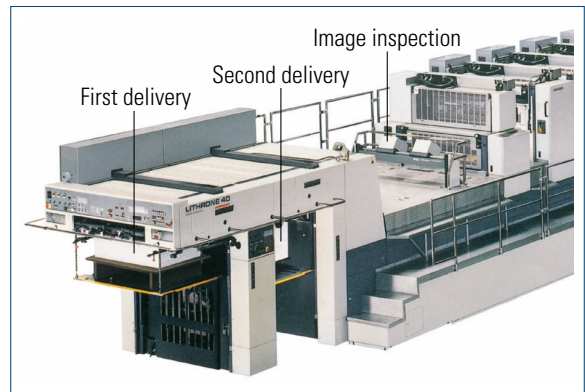


The rollers move downwards gradually as the auxiliary pile gets heavier



The empty pallet is beneath the rollers which now move back

**Fig. 2.1-71** Pile change at the delivery using rollers (KBA)



**Fig. 2.1-72**  
Dual-stream delivery and image inspection (Lithrone 40, Komori)

shows a press with double-sized impression cylinders and a two-revolution transfer drum between the printing units. The transfer drum acts simultaneously as the impression cylinder for the perfecting unit.

### Rainbow Printing

**Figure 2.1-76** shows a special ink fountain. Ink fountain dividers separate the ink fountain into several segments crosswise to the direction of printing. Each segment of the ink fountain can be filled with a different color, meaning that several inks can be printed on the sheet (side by side) in one printing unit. This ink fountain variant is used for special applications such as rainbow printing (printing of securities). Deliberate use of lateral distribution allows the inks to run into each other in the intended areas to produce special color effects during printing. The application of this in newspaper printing is illustrated in [figure 2.1-211c](#). The printing plate is inked in different colors through ink fountains which are arranged next to each other.

## 2.1.3 Web-fed Offset Printing

### 2.1.3.1 Press and System Concepts (Components)

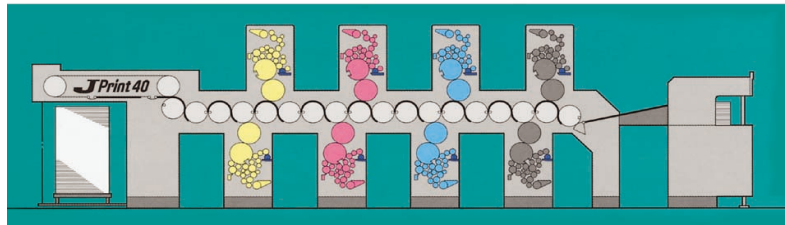
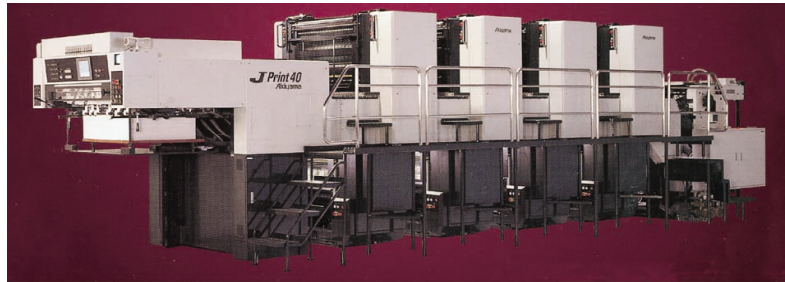
Web-fed offset presses are production flow lines where the product is also a means of transportation. Therefore, it makes sense to describe these lines by following their production cycle, that is, to start by describing the feeding-in of the unprocessed material – the paper reels. Web offset presses are usually categorized into either press types operating on the *heatset* principle for

**Fig. 2.1-73**

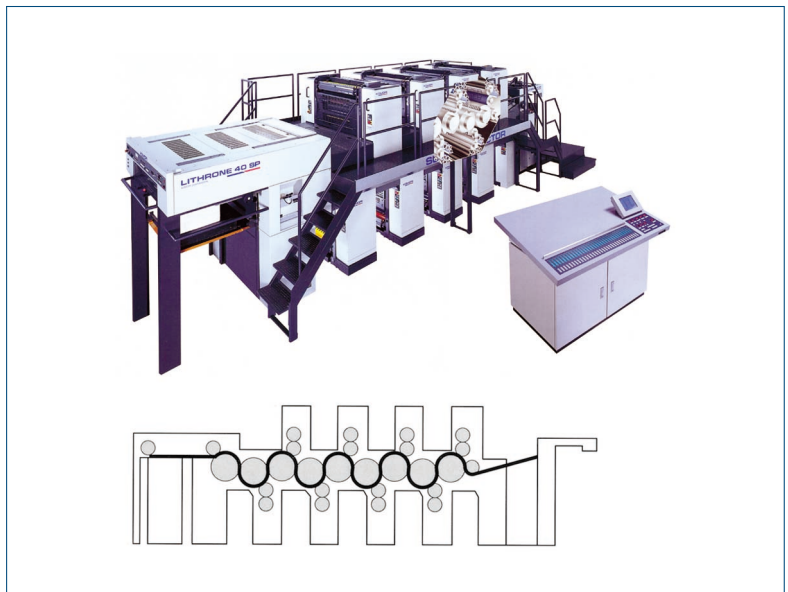
Reel-to-sheet equipment with sheeter for cutting the web instead of a feed pile, and feeding system (KBA/MAN Roland)

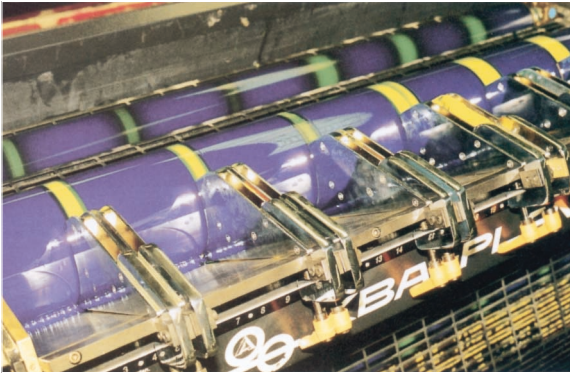
**Fig. 2.1-74**

Perfecting (4/4) without sheet reversal with single-sized impression cylinder (JPrint 40, Akiyama)

**Fig. 2.1-75**

Perfecting (4/4) without sheet reversal with double-sized impression cylinder (Lithrone 40 SP, Komori)





**Fig. 2.1-76**

Ink fountain with ink fountain dividers for printing different colors (rainbow printing) in one printing unit (KBA)

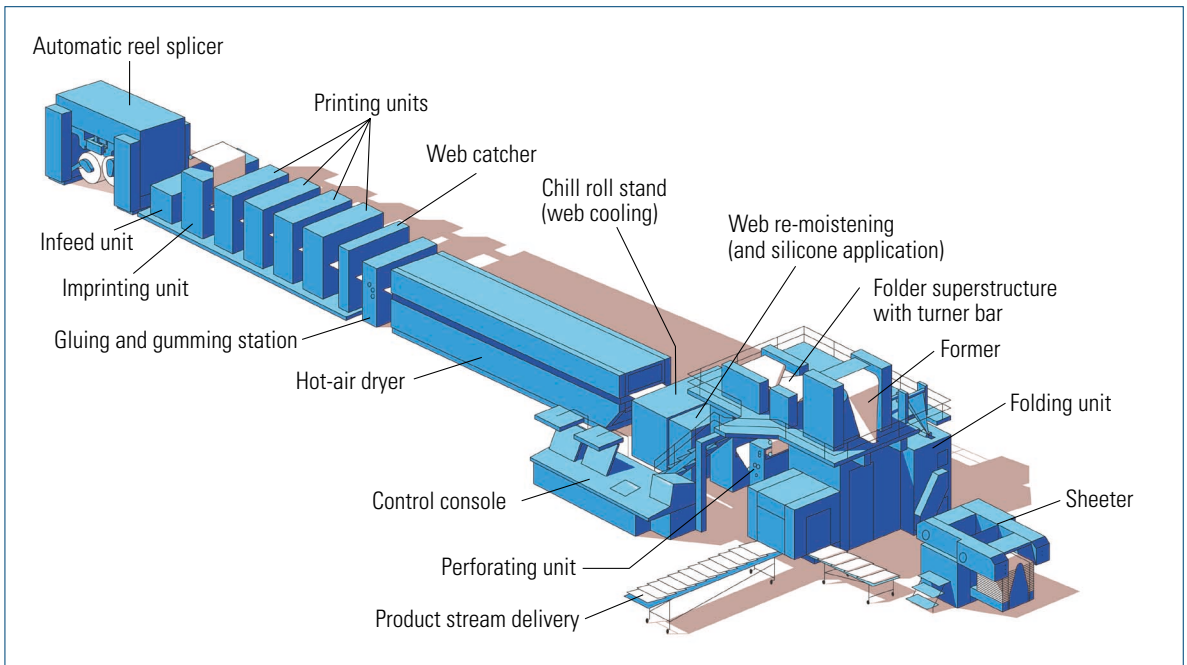
the production of commercial print jobs, magazines, and publications (fig. 2.1-77) or newspaper offset presses operating on the *coldset* principle. However, both press types are described together in this chapter. The fundamental differences will be dealt with in a separate section (2.1.3.5).

### Paper Reel Store

Due to a high level consumption, stocking up and storing the paper reels is an important aspect for web off-set and newspaper printing companies. Great emphasis is placed on unloading and handling the paper reels, as the printing company can keep useful statistics and give proof of damage caused during transport only if the reels are also monitored upon receipt. If damage has been caused and the printing company wishes to make a claim for compensation with the insurance company, the following details need to be recorded while an employee of the shipping company is still present:

- the number of reels,
- the type of damage (edges, reel body, front sides, noncircularity, packaging damage, or damage caused by water),
- the extent of the damage,
- the possible cause.

The importance of reel inspection still holds even if unloading is to be carried out automatically, as the reels may have been damaged before being accepted.



**Fig. 2.1-77** Web offset press components (M-600, Heidelberg)

## AGV Transport

Figure 2.1-78 shows the connection between paper storage and pressroom. In order to avoid losses, rather than to cut staff, further transportation of the paper reels in the printing company is now carried out by *Automated Guided Vehicle (AGV) Systems*. A paper reel is picked up on v-blocks (or on an arbor) by small transport vehicles powered by rechargeable batteries. These vehicles are controlled by a central computer via radio signals and directed by an induction wire which is installed in the floor. This results in higher flexibility and lower overall costs compared to chain-driven, floor-mounted conveyors. Besides induction wire-directed vehicles, there are also vehicles in use today which steer themselves by means of an integrated optical sensor system and prominent location marks in the warehouse. For reasons of safety, the vehicles are equipped all around with proximity sensors and flexible bumpers to avoid injuring any staff in the vicinity.

## Unpacking Paper Reels

Upon removal from the storeroom, the paper reels are taken to the unpacking station by the AGV, where they are unpacked by a semi-automated or automated process, or else manually. For unpacking the reels manually, a knife is used for the side caps and a plow blade knife to open the belly wrapper; however, over the last ten years, semi-automated devices have been developed where the reels are turned by motor, and the packaging material is disposed of by a shredder which is within easy reach above the head. Inspired by examples from Japan, there are also systems with a fully automated unpacking process, where circular knives cut

away the side caps, slit open the packaging on the circumference and transport the packaging material to the shredder via a conveyor belt.

If the reel identification is not carried out by the AGV, a barcode label (peel-off label) must be peeled off the reel label (fig. 2.1-79) before the reel label is destroyed and stuck on to the reel core so that the unpacked reel can still be identified.

## Preparation for Pasting

After the reel unpacking section there is a station for preparing the pasting. This sets up the flying reel change, that is, the front end of a new paper reel is glued to the tail piece of the expiring reel while the press is running. Here again, a distinction can be made between manual, semi-automated and automated devices. Auxiliary devices range from a ruler or stencil to

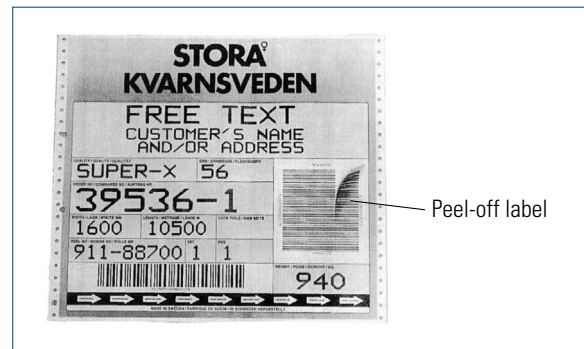
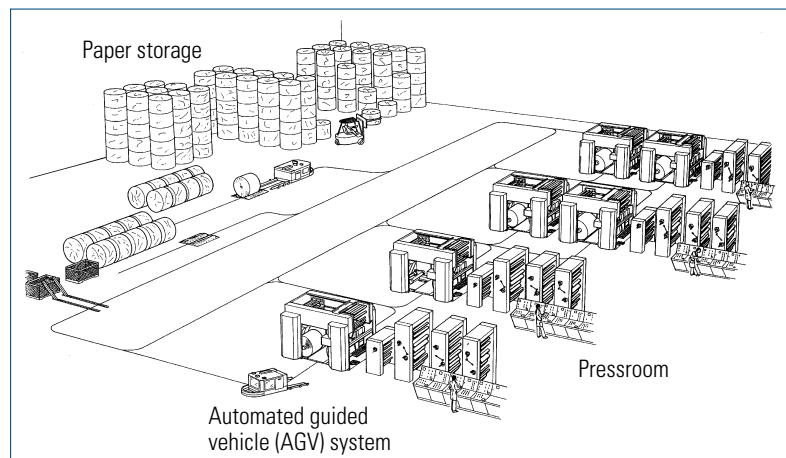


Fig. 2.1-79 Reel label with barcode and peel-off-label (IFRA)

## Fig. 2.1-78

Material transportation from the paper store to the pressroom using driverless transport systems (IFRA)



a splice preparation robot for fully automated execution of such operations as outer layers alignment removal, V- or W-shape trim of the web, application of the glue or the double-sided adhesive tape, and putting on the splice tap (metal or black marking) and the adhesive seal. The paper reel is prepared by the robot alone. In Japan, a large number of robots of this kind are already in use, but other countries are still a little hesitant to install such automation systems. Occasionally there are devices integrated in the reel stand. This requires two back-to-back reel stands.

### Reel Stand/Reel Splicer

The main tasks of a reel stand or a reel splicer are

- to unwind the paper reel,
- to tension the paper web and keep it at constant tension, and
- to change the reel fully automatically (depending on the types of paper reel).

There are a large number of different paper reel stands available, ranging from the simple unwinding frame to high-performance autopasters for fast-running newspaper web offset presses. Features of reel stands are:

- simple unwinding with supporting axle clamping or shaftless,
- bud splicer,
- flying reel change with one-arm, two-arm, or three-arm reelstand.

Another design feature is the type of reel drive with or without a belt (core-driven).

The “flying” reel change (fig. 2.1-80) is carried out in the following automatically executed sequences:

- Clamping the new reel in the chucks.
- Moving the new reel into working position (the new reel is moved to a distance of 1 cm from the expiring web, which is protected against fluttering by a support roller).
- Acceleration of the new reel to the circumferential speed of the expiring web.
- On passing the splice marking, the expiring web is pressed down to the circumference of the new reel by means of a foam roller (formerly a brush). The adhesive end of the new reel sticks to the expiring reel and at the same time the paste seal is broken.

- Swinging in the separating knife to cut off the remaining piece of the expiring web.
- Braking and ejection of the expired reel while the new reel is active.

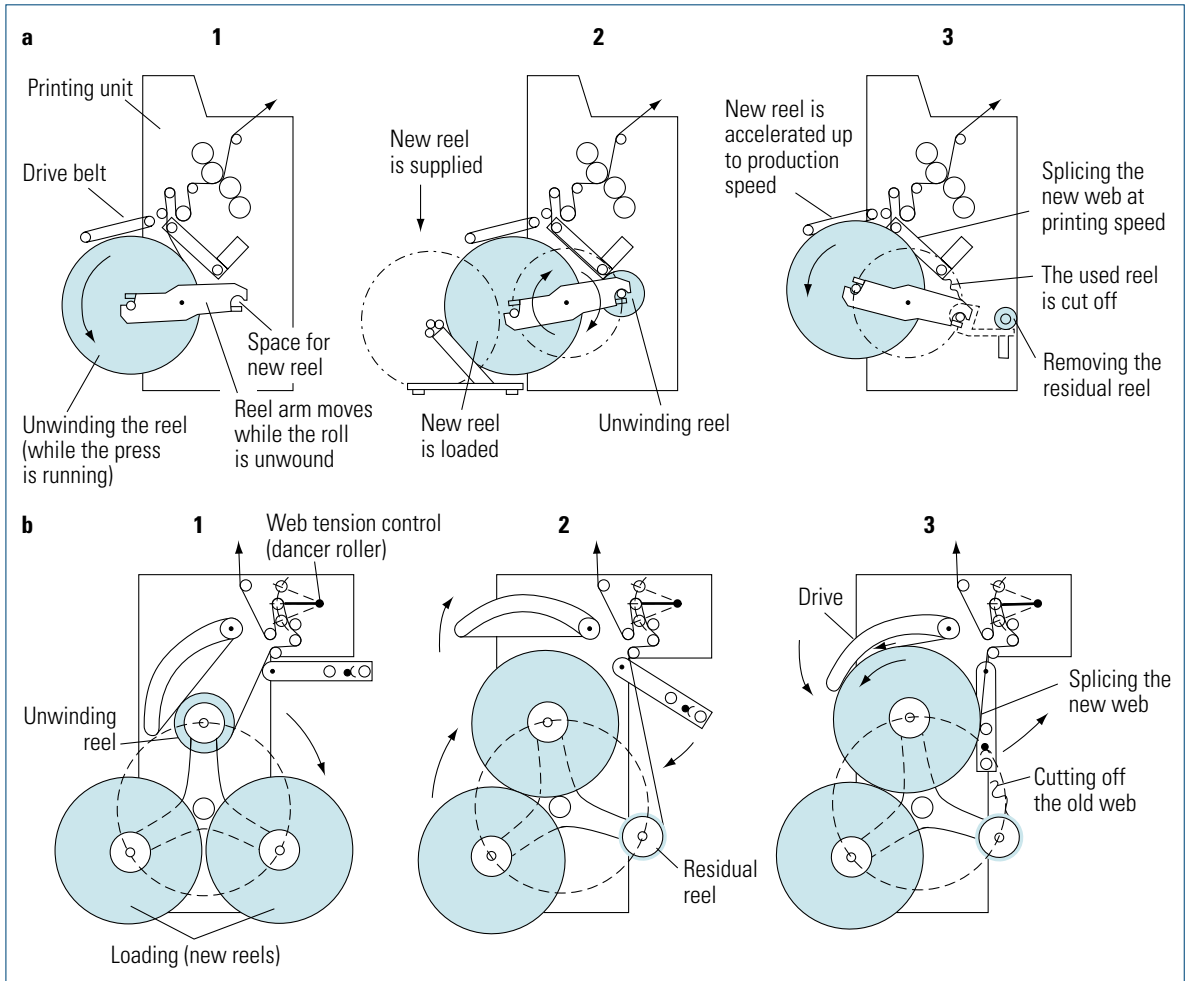
The expired residual reel is placed in a carriage and removed; the carriage is moved onto the sliding platform – in most cases by the AGV and the chain-driven hunt (a transport vehicle for the paper reel, which is guided on rails). The full carriage is moved to a waste disposal store, where the waste paper and the printshop waste come together to be compressed in presses into space-saving bales. The waste disposal store has an approach ramp to transport the bales and bulk goods to the recycling plant.

Reel change in *zero-speed web splicers* – frequently used in commercial web offset presses – is carried out in a completely different way (fig. 2.1-81). The paper reels are not carried on tilting brackets but solid in the frame – one reel on the top and one reel at the bottom of the frame. The paster device (paster head) is placed in-between, and the web storage (festoon) is located behind the reel stand in the form of meandering paper loops running between two batteries of idle rollers. The new reel is mounted in the frame by a ceiling crane and roll-down rails.

For reel change, the front end of the new reel is mounted in the paster device (paster head), and the speed of the expiring reel is reduced by braking. When braking down to a standstill, the web storage is emptied proportionally by moving the idle roller batteries together, thus keeping the web offset press running. A paster tab is inserted between the pinched front end of the new reel and the idle expiring web (after the latter has been bled-off horizontally with a knife), thus providing bud-splicing without the tail pieces overlapping.

When pasting occurs at a standstill the new reel is accelerated by a belt drive up to production speed and momentary overspeed, in order to fill up the web storage by moving the idle roller batteries apart. Later versions of this zero-speed web splicer put the web storage in a horizontal position above the reel stand (fig. 2.1-82) and use brackets instead of a ceiling crane to mount the new reel more easily.

For *newspaper web offset presses*, two or three-armed reel stands are used for the flying reel change. In general, three-armed versions are in use in North America, whereas in Europe two-armed versions are preferred. The three-armed version is advantageous only



**Fig. 2.1-80** Automated reel change.

**a** Reel splicer, two-arm version (simple version, integrated in a printing unit);

**b** Reel splicer, three-arm version (IFRA)

if no more than three reels are required for one shift. The paper reels can then be preloaded and are not in the way. Since two-armed and three-armed versions operate in the same cycle time, neither offers advantages over the other under normal operation.

To trigger the reel change process automatically, the web sequence has to be electronically monitored. Paper consumption is measured continuously, for instance by tachogenerators, and the expiring reel diameter is calculated accordingly. Once the expiring reel has reached a certain diameter, the signal for turning in

the new reel, accelerating it and so on, is transmitted. Naturally, operational data evaluations and statistics on web tear can be compiled for the reel change. For this purpose it is necessary to identify the individual paper reels before mounting, for instance, by barcode, either by inserting peel-off labels from the reel label in protocols, or by central assignment during goods inward inspection and AGV transport. In this way, the status of individual paper reels in the workshop can be clearly defined and monitored.

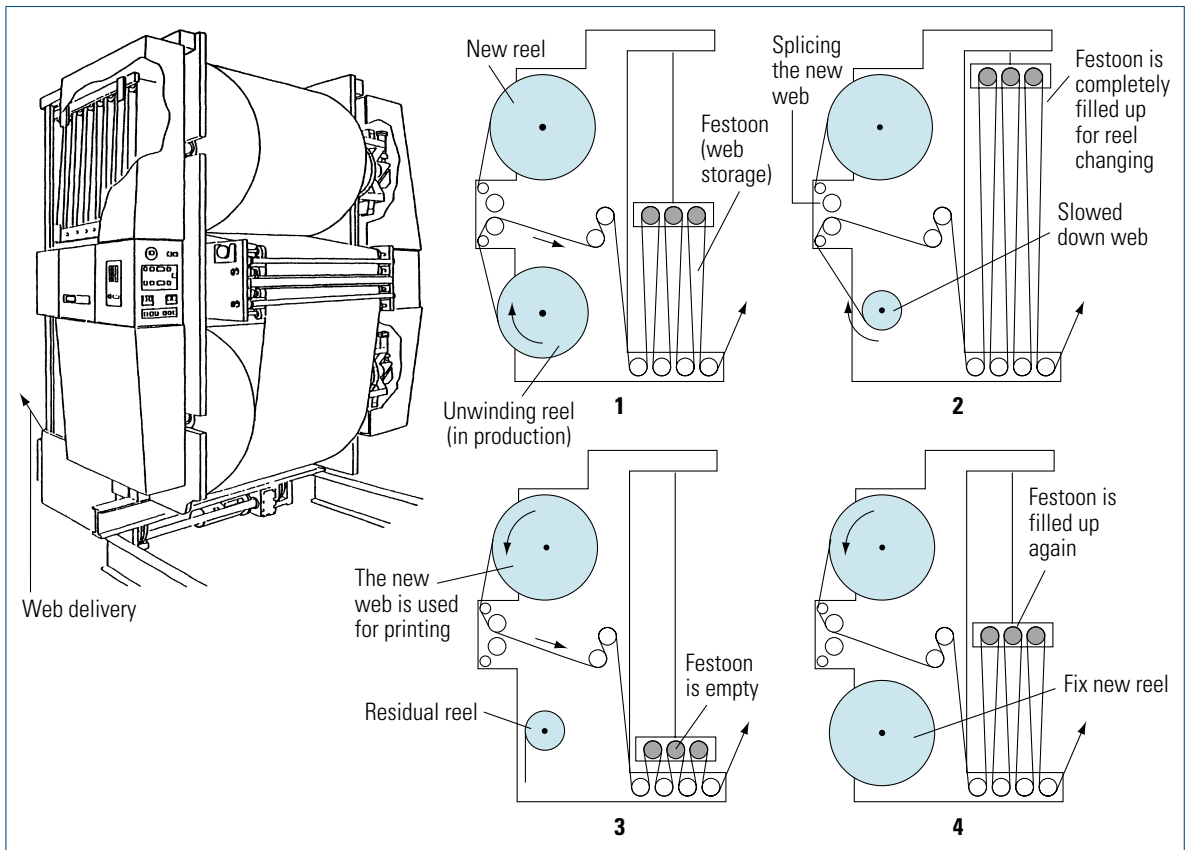


Fig. 2.1-81 Zero-speed web splicer (Buttler)

### Pre-Tensioning Unit (Infeed Unit)

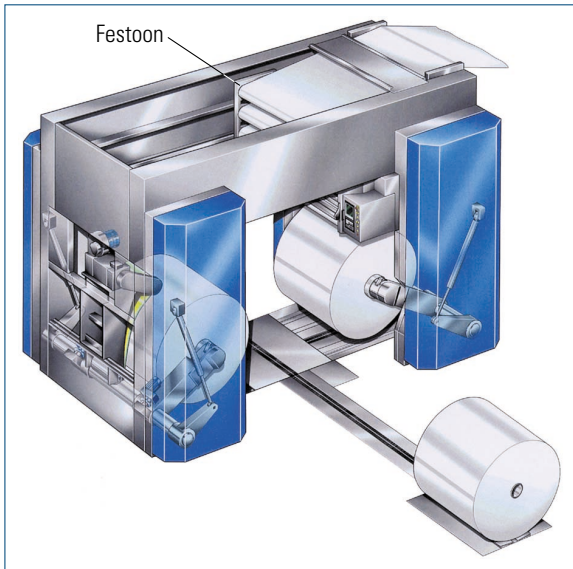
Generally, the adjustment of web tension, which serves above all to provide even unwinding of the paper reel, is carried out in the reel stand. Today it is also usual to place a pre-tensioning unit (infeed unit) in front of the first printing unit to serve as further web tension control. The pre-tensioning unit for web offset presses is an independent unit standing in line with the processing units (see also fig. 2.1-98). The pre-tensioning unit used with newspaper web presses is either housed in the substructure of the printing units or attached to the reel stand. The pre-tensioning unit is essentially composed of a draw roller with either nip pulleys or a pressing roller (three-roll units that only operate with looping effect have also been constructed), together with a downstream measuring roller for determining the tensile force of the web.

In the past, a mechanical variator was controlled at the draw roller in accordance with the measuring sig-

nal, and was later replaced by a direct-current servomotor positioned at an HD drive (HD = Harmonic Drive). The HD drive is a compact gear with a very high step-down ratio and has the capability of overlaying another movement coming from the servo motor. Today, this is only carried out by motor-controlling means for frequency-controlled alternating-current direct drive (shaftless), and so it becomes a very compact control unit.

In web offset, a web cleaner is frequently operated either by rotating brushes and vacuum suction removal, or by electrostatic forces and idle brushes, or else by a dampened cleaning cloth. Very careful handling of the web surface is important to avoid creating any fresh dust produced by detached paper fibers. In papermaking, dust is already produced when paper webs rub against each other and when the tambour is cut up into the required reels at the paper manufacturer's.





**Fig. 2.1-82**  
Zero-speed web splicer in horizontal configuration (simplified reel change) with integrated festoon (SH 50-RO, Heidelberg)

### Web-Threading Device

The paper-threading device for automated or semi-automated paper web-up is of great significance for newspaper web offset presses, as it is for heatset web offset presses. Here a distinction must be made between devices with endless or finite web transport systems on the one hand (and the necessary machine parts for this), and belts, chains, and flexible conveying elements on the other.

The simplest version is composed of continuous belts between the reel splicer and the folder running at the edge of the paper web, with loops into which the front end of the web can be inserted in such a way that the paper web can be directed through the press. The paper-threading infeed device is of an endless design (i.e., it always goes back to the starting point, and so it is always ready for operation). The device is driven by a servo-motor and disengaged on completion of the feeding process. The guiding belts on the left and right sides of the web can follow different paths, thereby providing two different lead versions.

As far as the further development of the paper-threading device is concerned (fig. 2.1-83), finite chain sections 2 to 3 m long are used, driven at the same distances by sprocket wheels with pneumatic motors.

Switches are used to lead to different web paths. Through reverse motion they arrive back in their original position.

### Printing Unit

The printing unit is just one component of the production chain of the whole production system. Details of the construction of the printing unit or the printing couple are given in section 2.1.3.3.

A *printing couple* is the single component used to print ink on one web or sheet side characterized by a plate cylinder and a blanket cylinder (couple) with associated dampening and inking units, whereas a *printing unit* in web offset printing is composed of several printing couples combined into one closed unit. The simplest version of a printing unit is the vertical *blanket-to-blanket* one which uses a horizontal web-lead to print one color on the front and reverse side of the web; this is standard in *web offset printing* (fig. 2.1-84). The printing section is composed of two printing couples arranged in tandem.

In *newspaper printing* units are arranged more often horizontally than in the vertical because multi-web production is most widely used and it is easier to gather the individual color-printed sections in a vertical line before the individual webs are merged horizontally (see also fig. 2.1-87).

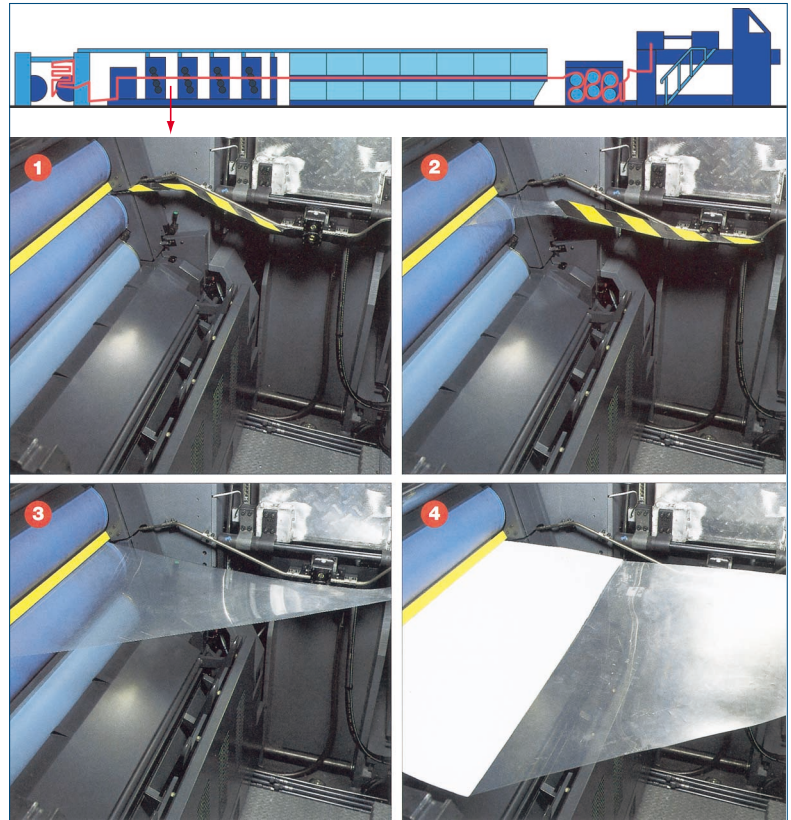
Depending on the *installation arrangement* of the printing system, there are *one-level* and *multi-level presses* (see also fig. 2.1-190). The reel stands can be positioned in front of or below the printing units. A reel stand made to specification can also be placed behind (next to) the printing units, and the web is directed in the travel direction of the web to the printing units via a turner bar.

Several means are employed to bring the printing units above reel stand level. There is the concrete substructure – designed as a table with supports that rests on a concrete foundation. The concrete foundation is mostly of a box-type design and rests on adjustable spring assemblies. The foundation is accessible and provided with electronic position detectors serving as early warning devices (for stability, position, and vibration behavior). Leveling wedges with special vibration-absorbing lining are arranged between the printing units and the concrete substructure and serve as damper (absorber) sections acting against the transmission of machine vibrations.

The concrete substructure is of solid design. However, it is not very adaptable (i.e., system extensions or system modifications are very difficult to implement).

**Fig. 2.1-83**

Automated threading in a web offset press. (Photos 1-4 show how the web is fed into the printing unit.) (M-600/Autoweb Up, Heidelberg)



Due to this, steel substructures are mainly preferred to concrete substructures nowadays. Steel substructures are supplied in pieces that can be screwed down, taken apart again, modified or supplemented. The steel substructure for light machines can be made of two double T-beams lying on the reel stand frames carrying the printing units. Substructures made of cast iron are also in use.

**Imprinters.** They can be installed in web offset systems to serve as accessory printing units. A voluminous print run can thus be divided into individual print-run segments by imprinting various texts or additional information on the fly differing regionally in one color, for example, in different distributions.

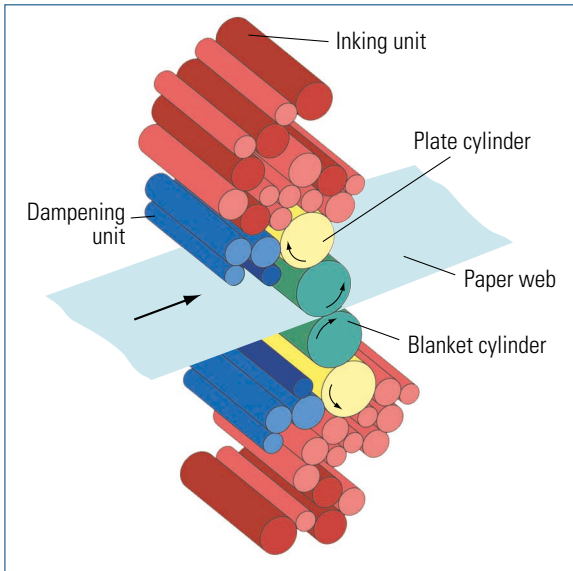
Besides *offset imprinters*, there are also *flexo imprinters* used in newspaper printing that feature a simple inking unit structure. However, in general they require a dryer for the low-viscous ink (see also [sec. 2.3.3.2](#)). The changeover procedure in both cases, offset and flexo, is in principle the same. Flying plate change tech-

niques – the interaction between the active printing unit and the uncoupled printing unit in preparation – are also used today for the “primary” print of newspapers and even for the relevant four-color set.

### Dryers

In newspaper printing, the printing ink dries on the paper substrate by mere absorption or penetration into the paper fibre body (“*coldset*” method). In commercial printing, the printing ink on coated papers, that is, less absorbent papers, also needs to be dried by heat evaporating the solvent (*heatset* method). Long extended hot-air dryers are used ([fig. 2.1-85](#)) to blow hot air over both sides of the fresh print via nozzles. The upper and lower nozzle bars are staggered; the blast direction of the nozzles for the drying air is set in such a way that the nozzles also serve to carry the web, that is to say, supporting idler rollers are not required in the dryer (see also [fig. 1.7-9](#)).

Precautions have to be taken to make sure that the web does not remain in the dryer in the event of a web break; this would result in burning. To this end, a pair



**Fig. 2.1-84**  
Blanket-to-blanket printing unit of a web offset printing press (M600, Heidelberg)

of pinch rolls is mounted in front of the dryer at the web infeed to secure the web front end if there is a web break, while the web tail is transferred automatically out of the dryer by folder traction. In addition, flaps on both sides of the dryer open automatically to ensure a rapid temperature drop in the dryer area.

In the past years, much was done to optimize hot-air dryers, for instance, by way of nozzle geometry design and formation of optimum temperature profiles in the

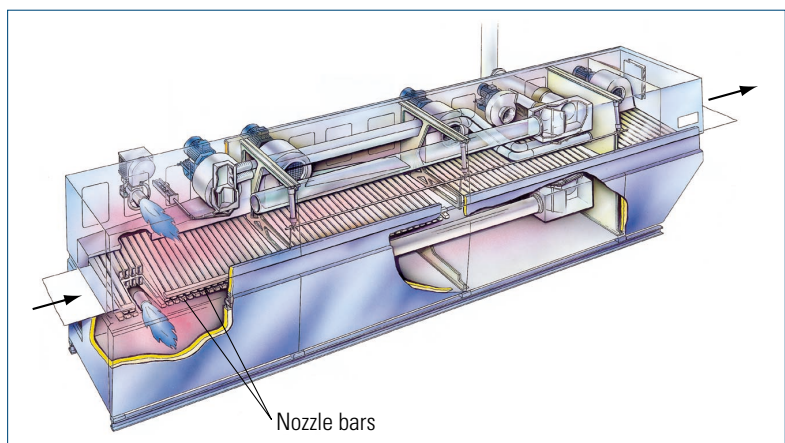
travel direction of the web. Combinations of hot-air dryers and infrared dryers are also in use. Infrared dryers are used in newspaper printing only to stimulate ink absorption, thereby facilitating printing with higher ink density, that is, with higher ink application. Nowadays UV radiation dryers are hardly ever used, due to their limited quality (there is no “ink melting effect” giving brilliance) and to the high printing ink costs they incur in web offset. For the same reason, electrobeam dryers or ink curing systems have not come to be generally accepted in practical operation, although they have good drying properties.

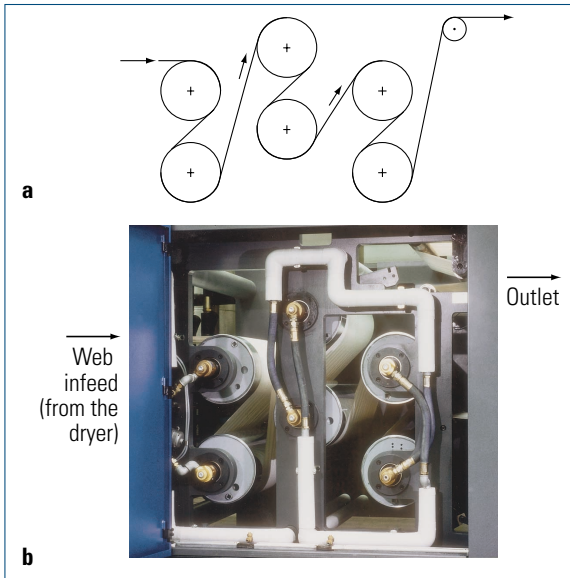
Hot-air dryers producing hot air by gas burners are equipped with catalytic afterburners to keep waste air clean. For heat recovery, these afterburners are switched in a circuit with the dryer. As far as highly productive web offset systems are concerned, heat recovery demands more attention today than it used to, and appropriate investment is required.

### Chill Roll Assembly/Stand

Both the hot-air drying method and the infrared drying method require a cooling process, as the printing ink and the paper web heat up to approximately 130 °C, thereby affecting plasticity and tackiness of the printing ink. Cooling is carried out by a set of chill rolls mounted in the chill roll assembly (fig. 2.1-86), which is provided with air knives and an exhaust hood. The web winds round the chill rolls at the greatest possible angle of wrap to ensure effective cooling of the web by direct heat conduction. The air knife/blade “removes” drag air before the web makes contact with the following chill roll, and the air is then

**Fig. 2.1-85**  
Hot-air dryer for web offset printing presses (Ecoweb Convertible, Heidelberg)





**Fig. 2.1-86** Chill roll stand with six chill rolls.  
**a** Chill roll configuration with web travel;  
**b** Chill roll stand (Heidelberg)

sucked off above the exhaust hood. The temperature of the expiring web should equal room temperature.

### Folder Superstructure

Due to their different functions, the folder superstructure and the folder will be dealt with separately. Cut-off, separated products are processed with the folder, whereas continuous web-shaped products are processed in the folder superstructure. The main functions of the folder superstructure include *longitudinal slitting* the web and *superimposing the ribbons* produced in this way into ribbon bundles *via turner bars* (fig. 2.1-87). In order to avoid web breaks, draw rollers are required, together with measuring and control devices to maintain precise web tension.

Commercial web offset presses are very often equipped with a *silicone application unit*, which is installed in front of longitudinal slitting devices and the turner bars to avoid ink set-off and possible smudging on the deviation elements (fig. 2.1-77). Silicone application units are either continuous-type H-type systems or jet units transferring water-soluble silicone onto the print carrier. *Remoistening* of the web is required if drying dehumidifies the print substrate so much that further processing might become difficult.

*In-line finishing* devices, such as plow blade folding systems, perforating, or glue application units, are often housed in the folder superstructure. Punching operations are generally carried out with separate racks.

The *former* (fig. 2.1-88) is the most important part of the folder superstructure, in both commercial and newspaper printing. The first *longitudinal fold* is executed by the former (as far as tabloid products are concerned, the former can just be seen as a turning device with the round former side-walls acting as turner bars, see section 2.1.3.4). In general, the former walls are cone-shaped, diminishing to the former nose and washed round by air escaping from small blast air nozzles to reduce friction. The roller top of former (RTF), a driven draw roller, is mounted at the infeed of the web or webs onto the former, where the superimposed ribbons are gathered into a ribbon bundle.

It must be ensured that each ribbon is governed by defined traction conditions. Therefore, two draw rollers, that is, RTFs, are arranged closely in tandem in order to seize the ribbon bundle. The ribbons are pressed on the draw roller by spring-loaded rubber-coated nip pulleys (similar to those in fig. 2.1-89 for the draw rollers). The former nose (fig. 2.1-88) is a crucial part of the former. The geometrical design of the former nose is calculated or optimized more through practical tests than in theory. The nose shape is responsible for both folding quality and folding productivity. The former nose is followed first by the infeed rollers, non-driven but provided with a cross-ribbing, then by the twin draw rollers (sandwich rollers) of the succeeding folder, which take over the product (fig. 2.1-89).

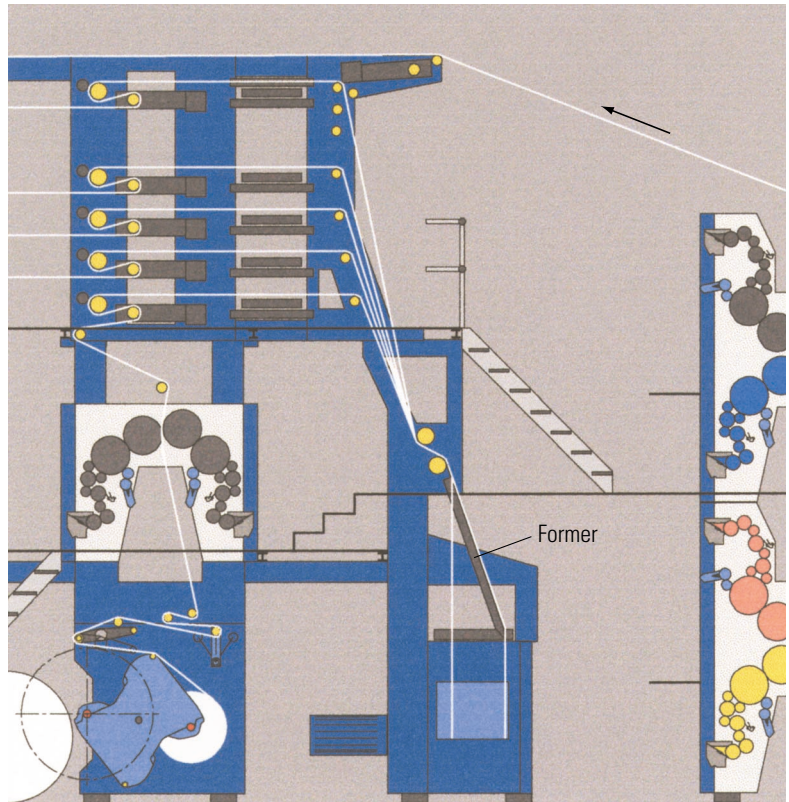
### Folder

The folder (e.g., fig. 2.1-89), or “folder cylinder part”, starts with the above-mentioned sandwich rollers, mostly in the form of multi-layer rollers (similar to fig. 7.2-24) with rubber and steel rings alternately fitted together in the axial direction through which the ribbon bundle travels. The draw rollers are provided with a separately adjustable motor drive.

The ribbon bundle is cross-cut with the serrated knife of the cutting cylinder. The cutting cylinder moves against a cutting bar on the tucker blade cylinder. Simultaneously, the front end of the ribbon bundle is held on the tucker blade cylinder by pins so that it follows the latter (fig. 2.1-89). As soon as the rear end is cut in the succeeding cycle, the ribbon bundle is turned into a sheet bundle which lies on the tucker

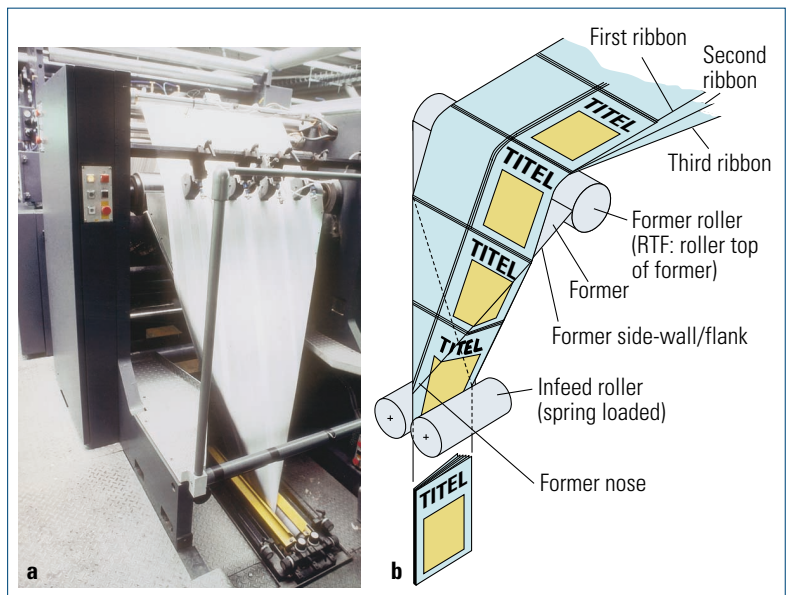
**Fig. 2.1-87**

Folder superstructure on a newspaper offset printing system for gathering several webs/ribbons before they are fed into the folder (KBA)

**Fig. 2.1-88** Former.

**a** Former on a web offset press (M-600, Heidelberg);

**b** Former with 3 webs running in (IFRA)



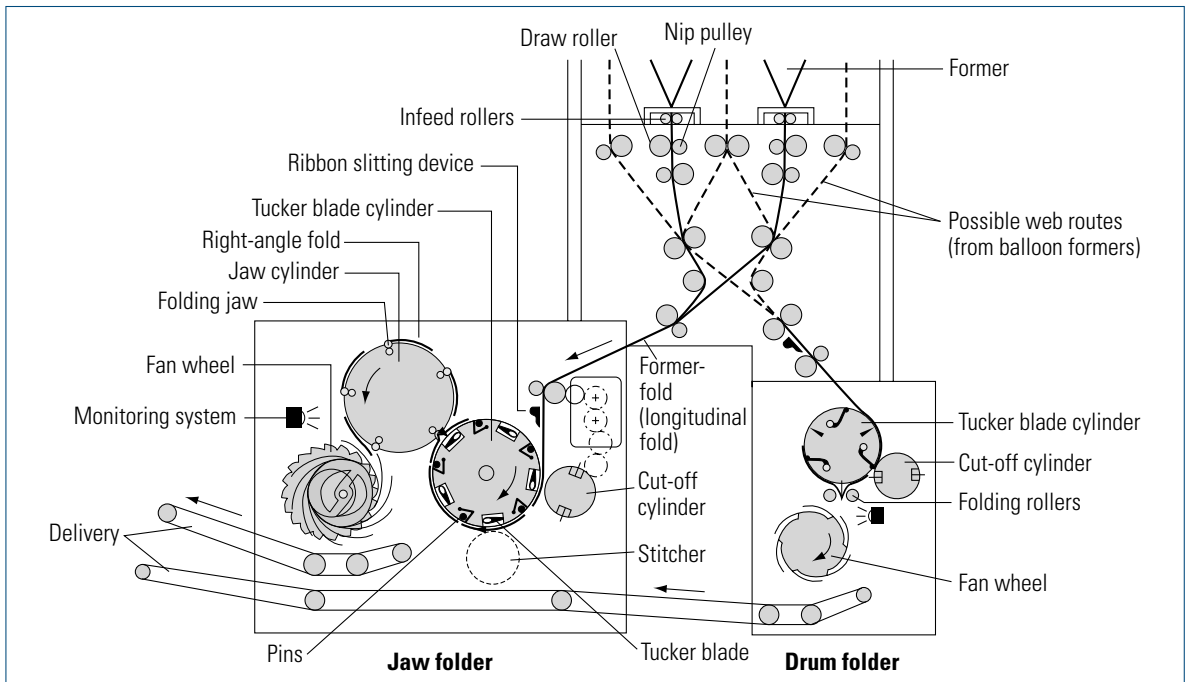


Fig. 2.1-89 Double folder (2:5:5 with 2:3), (MAN Roland)

blade cylinder. In the case of collect-run production, the tucker blade cylinder revolves twice, that is, two succeeding layers of sheet bundles are superposed before the fold is executed. Both layers are held by pins.

To execute the *right-angle/cross fold*, the cam-controlled tucker blade emerging from the tucker blade cylinder at the narrowest pass pushes the sheet bundle into the open folding jaw of the jaw cylinder. The folding jaw closes directly (spring-loaded), thereby folding the product and effecting further transportation. The folding jaw on the opposite side of the jaw cylinder opens, and sheet separators direct the product supported by the force of gravity into a fan wheel. The crooked shovels of the fan wheel reduce the traveling speed of the product and stagger the product in a shingle-like stream. Rotating stops and lateral adjustable discs ensure that the individual products are accurately aligned from a geometric point of view and that they leave the folder on a delivery belt as a relatively slowly moving shingle stream.

For special purposes, a third fold can be executed as a *quarter fold* (or second *longitudinal fold*, chopper/cross fold) before the product reaches the fan wheel (fig. 2.1-90). Different folder configurations are described in section 2.1.3.4.

### Open Sheet Delivery/Sheeter

For commercial web offset presses and complicated folded products, it is useful to deliver unfolded sheets to an open sheet delivery (sheeter) rather than via a folder (fig. 2.1-91). The larger the sheet, the more difficult it is to deliver. Generally, production speed needs to be cut. As far as wider sheets are concerned, the trim itself is difficult when executed as a straight-cut. Trimming by a rotating knife against a stationary lower knife is only partly satisfactory; an upper and lower knife, both rotating, are preferable. Through advanced drive technology, the product is accelerated in the circumferential direction to produce the follow-on trim as a shear cut (figs. 7.2-9 and 7.2-10). It helps to put the sheets on the subsequent delivery in a shingled stream, in order to provide better grip and to gain more time for aligning. All other functions as regards stack lowering and pile change are similar to those of the sheet-fed printing presses.

### Ink Supply

Nowadays web offset presses are supplied with ink via *returnable container systems* or stationary tanks (see sec. 8.1.1.3 and fig. 8.1-6). Returnable containers are steel

Fig. 2.1-90 Folding variants

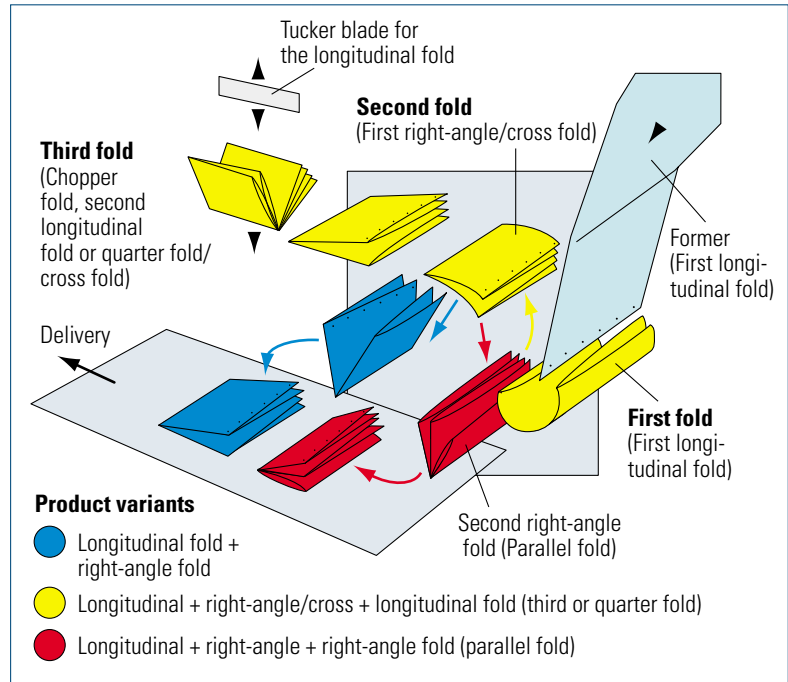
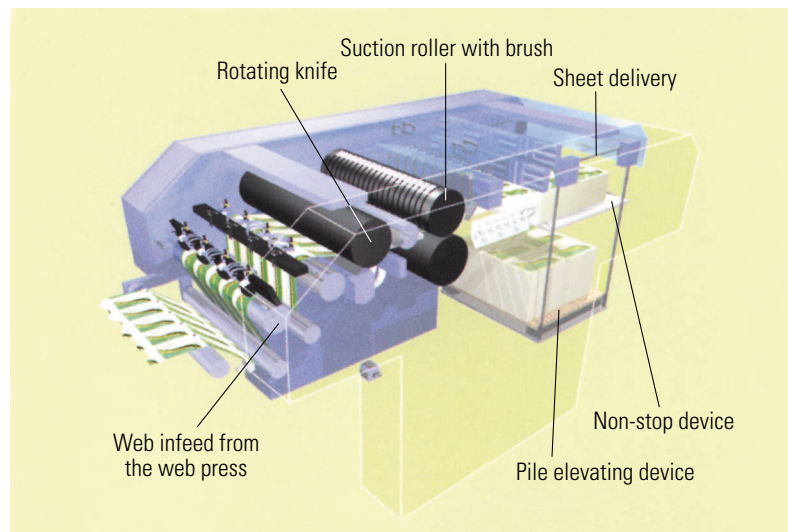


Fig. 2.1-91

Open sheet delivery (sheeter) for web off-set printing (VITS)



containers tapering to the bottom with a capacity of approximately 700 kg of ink; they are mounted on pallets. These containers are emptied by electrically operated plunger pistons mounted on a second pallet above the steel container and sealed against the container wall by relatively soft rubber lips. The printing ink flows

through the tapered part into a pipeline and then into the press. The stationary tanks are filled and emptied by regenerative pneumatic or electrical pumps.

For automated ink supply to the ink fountains of the individual inking units, it is vital that they are equipped with a *level control* in the form of a non-contact sensor

(fig. 2.1-165). Evenly metered ink in the ink fountain makes for reliable production and contributes to a constant ink feed into the inking unit.

It is useful to attach an *ink agitator* to the ink fountain for high-viscosity inks used in commercial printing, that is, a motor-driven cone-shaped stirrer (fig. 2.1-92), which rotates steadily and moves to and fro alongside the ink fountain via a toothed rack. In this way, constantly conditioned ink is supplied to the inking unit.

For *spot colors*, which are rarely used, it is often not worthwhile piping the presses, since only tiny quantities are used and cleaning becomes necessary when changing the ink. Therefore, small, wheeled containers equipped with manual plunger pistons are rolled to the ink fountains and from here the ink is filled into the ink fountains. To avoid storing many spot color inks, special ink mixing systems have recently been developed. These systems can automatically mix the desired spot color, in accordance with the HKS or the Pantone matching system from twelve basic colors. The four process colors are not sufficient to achieve the brilliance of certain spot colors, since they do not contain the special pigments required for this.

### Dampening Solution Supply

The dampening solution used in offset printing is 95%–98% water. Untreated water available from the city water network generally contains too many mineral salts, that is, it is too hard, and needs to be softened

before use. Softening is carried out mainly with systems operating by reverse osmosis. The process water produced needs a hardness of approximately 8°dH (degree German hardness, see definition in 2.1.1.2/Dampening Solution) for an optimum printing result to be achieved.

To turn the process water into a usable dampening solution for offset printing, a dampening solution additive needs to be added – preferably isopropyl alcohol, as it is offered on the market in many variations and can in general be matched to printing inks. In newspaper printing, special alcohol-free dampening solution additives are used. In addition, the pH value should be set and kept constant (approximate pH = 5), and steady cooling of the dampening solution at around 10 °C should be carried out.

Dampening solution for printing is supplied by dampening solution storage tanks and dampening solution circulating containers located at the press. Cooling the dampening solution, measuring and adapting the pH value, as well as adding the metered dampening solution additive – all these processes take place in the press-specific circulating containers, which, in most cases, comprise the dampening systems of several printing units. The cycle between the circulating container and the dampening systems in the press is provided by a pump fitted with valves located in the dampening water fountain which is itself controlled by automatic level indicators or by direct-connected nozzles for jet-spray dampening units. Today, this whole process is fully automated with appropriate measuring and controlling systems supplied by independent subcontractors.

### Control Console

Originally, the control functions of a web offset press only consisted of press drive commands that could be accommodated in a small switch panel at the folder. With increasing motorization/automation of most setting functions of the production plant, such as the side lay and circumferential register and the ink control, it became necessary to unite them in one central control console together with the accompanying operator control elements and displays (fig. 2.1-93). It was also useful to place the sample for inspection on a panel area so that the remote-controlled ink zones in the inking units could be allocated more quickly during ink feed adjustment. A web-offset press is usually equipped with one separate control console for the upper (front) side and one for the lower (reverse) side of the web. This resulted in very long control consoles equipped with operator controls and displays.

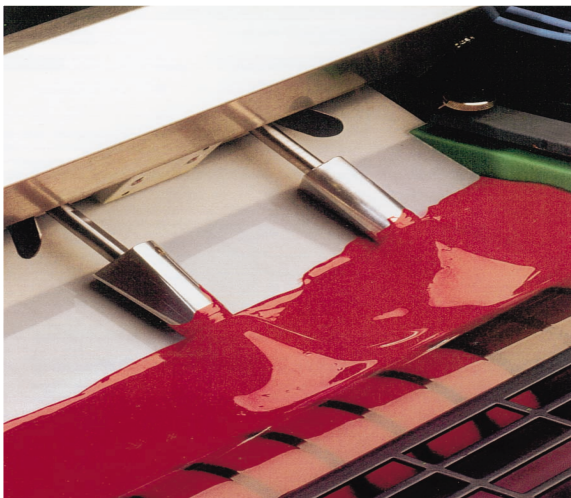


Fig. 2.1-92 Ink fountain with ink agitator (ESS)





**Fig. 2.1-93**

Remote control station for web offset press with separate operation consoles for upper and lower side of the web (Heidelberg)



**Fig. 2.1-94**

Control console with monitor (touch screen), ink zone and color register control functions (Ewert Ahrensburg Electronic)

The transition to programmable control systems in the mid 1970s, as well as the trend towards relocating control units from the switch cabinets into the press, made it possible to centralize the control console functions. Visual display units with synoptic graphic displays were introduced to reduce the number of individual display elements, and a large number of switches and push buttons were replaced by “soft keys” or touch areas on the screens (fig. 2.1-94).

In addition, the ergonomic design of the monitor control consoles was optimized; for example motor-driven console tops could be raised or lowered, thus allowing the operator to work either standing up or sitting down. The only hardware switches left on the control console are the main drive commands of the press and the keyboard for controlling the different ink zones. The former is there as a result of the requirements of the factory inspectors or the employer insurance liability organizations (see sections 13.2.2 and 14.6), while the latter provides for a better geometric allocation of zones to the sample sheet lying on the console.

Occasionally, separate control consoles are used for press operation and ink setting. Ink setting control consoles are equipped with standardized lights (D65 or D50) so that visual inspection of the color tone in the print compared to the “ok-sheet” by the operator is not interfered with by the interior lighting (fig.2.1-93).

*Measuring instruments* (see sec. 2.1.4) are used for quantitative evaluation of the color quality. This is usually carried out with hand-held densitometers. The best measuring standard, however, is achieved with colorimetric scanning using a spectrophotometer. Automation variants range from off-line measuring systems where the sample sheet is evaluated outside the press to in-line measuring systems integrated in the press. Camera systems can record an image section in real-time for visual inspection. Very often, in-line color register measuring and control systems are used.

At the push of a button, the *sample sheets* are automatically ejected from the sheet stream in the delivery.

### Noise-Protection Encapsulation

Constant efforts are being made to reduce noise emission of presses by primary measures (structural measures); they are often equipped with noise-protection encapsulations as secondary measures (fig. 2.1-95). Figure 2.1-96 shows how accessibility to the press is ensured. With large installations it is preferable to encase the control station in noise-protection walls, rather than encapsulate the entire printing system optimally (fig. 2.1-97).

Noise-protection encapsulation of web offset presses is generally achieved by covering the whole press with a housing (fig. 2.1-95) made of special multi-layer noise-absorbing walls with windows and doors. Figure 2.1-97 shows a noise protection cabin accommodating the control consoles for a newspaper rotary press.

Depending on the legislation applicable, a maximum noise level of 80–85 dB (A) is permitted at a workplace (see sec. 13.2.1). Current noise-protection encapsulations conform to these requirements. As not all press control functions can be managed by remote control, operators sometimes have to work directly at the press and thus may be exposed to higher noise levels. Should this be the case, the operator must wear earmuffs. To separate several press sections for acoustic reasons, partitions or movable noise-protection aprons hanging from above can be used.

#### 2.1.3.2 Web Travel (Infeed and Further Processing)

Since a web offset press features numerous components, links are required to ensure reliable web travel



**Fig. 2.1-96**

Access to the printing units on a web offset press with noise-protection encapsulation (Heidelberg)

**Fig. 2.1-95**

Noise-protection encapsulation (cabin) of a web offset printing system (Heidelberg)





**Fig. 2.1-97**

Control station in noise-protection cabin on a newspaper printing press (KBA)

and an efficient interaction of the individual processing stations. As already mentioned in [section 1.6.2](#), web offset presses and sheet-fed printing presses differ mainly in those press components effecting the transport of the substrate and less in the structure of the printing unit and inking unit.

### Web Tension Control

In contrast to sheet-fed offset printing, the paper web must be kept at a certain tension to retain a certain dimensional stability in web offset (register accuracy). Optimal tension depends on two factors: dimensional stability and risk of tearing. Control of the web tension is imperative, as on the one hand the elasticity of the paper web can change from reel to reel and, on the other, interference factors such as loss by friction affect the paper web tension.

The simplest way of achieving a certain web tension is to use an intermediate weighted pendulum or dancer roller. The dancer roller serves both as a sensor element

and at the same time the active element (actuator) of the control circuit, where the motion represents the measured quantity value and the compensated web load the manipulated variable (see also [fig. 2.1-8ob](#)). So that the neutral point can be retrieved, the controlling elements are provided with a PIV gear, which can change the transmission ratio.

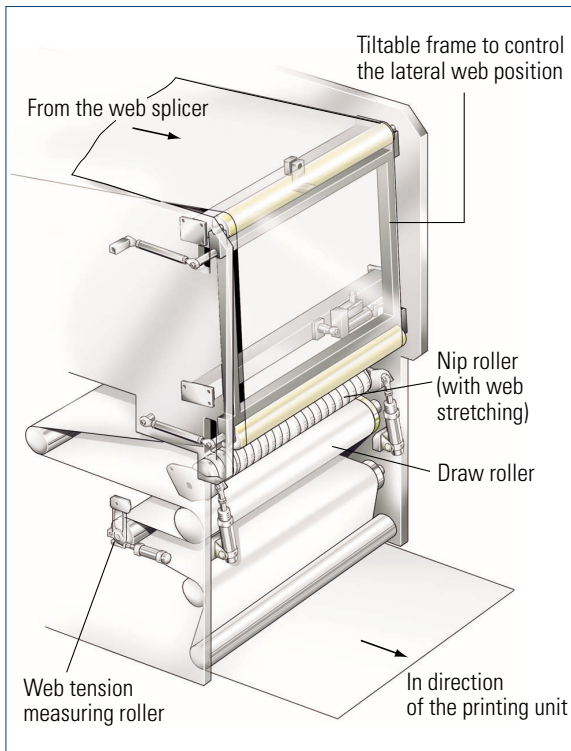
Since these mechanical controls are encumbered by the inertia of mass, they are no longer sufficient for today's high-speed web offset printing presses and have been superseded by electronic control systems. Here, a measuring roller, that is, a web guide roller, running on electronic load cells, is the receiving element; an electronic controller optimally converts the measuring signal into an actuating signal. The control of web tension by means of the draw roller drive took place in several stages. Nowadays frequency-controlled alternating current servo-motors providing fast data communication via optical fibers are used.

High-transmission HD gears (harmonic drive) and PIV gears, which are also adjustable during press run, represent essential innovation steps in web tension control systems. The fact that this development process has only taken ten to fifteen years bears witness to the significance and rationalizing effect (for mechanical engineering) of electrical engineering and electronics in conjunction with mechanics (mechatronics). This, however, meant that the simplicity of function elements was lost, which in turn meant that special skills were required of servicing and operating staff.

The key position for web travel, where the web tension is applied by a controlled draw roller as described above, is in front of the first printing unit, that is, after the reel stand. This point is referred to historically as the infeed unit ([fig. 2.1-98](#)). Nowadays, such controlled draw rollers are also installed after the printing units. The draw rollers act as clamping points, that is, they make use of spring-loaded rollers between which the paper web is guided. Since the paper web is flexible and the pulling forces are generated by the frictional forces, this process is an interaction of stationary motion and slipping, which takes place between the draw roller surface and the paper web.

### Web Edge Control

Various factors can cause the paper web to change its lateral position when leaving the reel stand. The whole paper roll can be moved up by the lateral adjustment of the reel stand shaft; however, this adjustment is too sluggish for dynamic control. Therefore, after leaving the reel



**Fig. 2.1-98** Infeed unit (Heidelberg)

stand, the paper web is directed over a tiltable frame of parallel rollers located in the infeed unit (fig. 2.1-98), which provides for the lateral adjustment of the web during travel. The motorized positioning movement is effected by a controller that is linked to a web edge sensor. A wide range of different physical working principles can be applied for designing these sensors, extending from simple light barriers, pneumatic, ultrasonic and infrared sensors, through to cameras with CCD arrays. A distinction must also be made between control using two sensors to control the middle position of the web or to check to right edge of the web with the right-hand sensor and conversely the left edge with the left-hand sensor.

### Register Control

Differentiation has to be made between the *circumferential* and *lateral register* in multicolor printing, the straight printing/perfecting register when printing on both sides, and the cut-to-print register in the folder. In addition, there is *diagonal register* or “cocking,” which serves to correct an image copied obliquely by cylinder

tilting (or plate shifting) and to compensate the “fan-out” effect of the web (enlargement of the web width) caused by the dampening during the printing process. With gravure presses, *print-to-print/color register control systems*, which are installed in-line and that adjust the register position during production automatically, are part of the standard equipment; however, they are now also used in web offset presses and newspaper web offset presses. Register control systems use optical sensors to detect register deviations on register marks printed on the web and initiate impression cylinder or web travel adjustments by means of servo-motors.

Register control is based on the following, proven principle: register marks are printed by each printing unit on the blank margin or on non-image areas on the prints. The deviation from the target position is measured by opto-electronic sensors and a correction impulse is calculated by the controller for the particular register servo-motor. Appropriate sensor or measuring systems can read very tiny register marks. Due to their size – sometimes only a fraction of a square millimeter – these register marks are hardly recognizable on the printed image, that is, they do not disturb the image and are easy to arrange. Newspaper printing presses using shaftless drive designs create optimal ways of register adjustment by means of electronic direct drives.

The latest development is aimed at recording print-to-print/color register together with other parameters in the print, such as image inspection and color measurement with special measuring devices, video cameras, and magnifying optics, which display the data on the screen for evaluation by the operator or make automatic adjustments.

*Cut-to-print register control* is necessary when running up the press, especially when using drum folders, in order to avoid a shifting of the fold in relation to the print. However, the shaftless drive has improved this situation to the extent that cut-to-print register adjustment can be occasionally left out.

### “Fan-out” Control

Control and adjustment of the lateral register is particularly difficult in *newspaper printing*, for instance, two times four individual printing plates are mounted on one plate cylinder across the printing direction and each plate has already been produced with a lateral register error (see fig. 8.1-4). With the normal lateral register adjusting mechanism it is only possible to move the whole plate cylinder, and so only one of the eight plates would be properly adjusted. The “fan-out” effect causes another

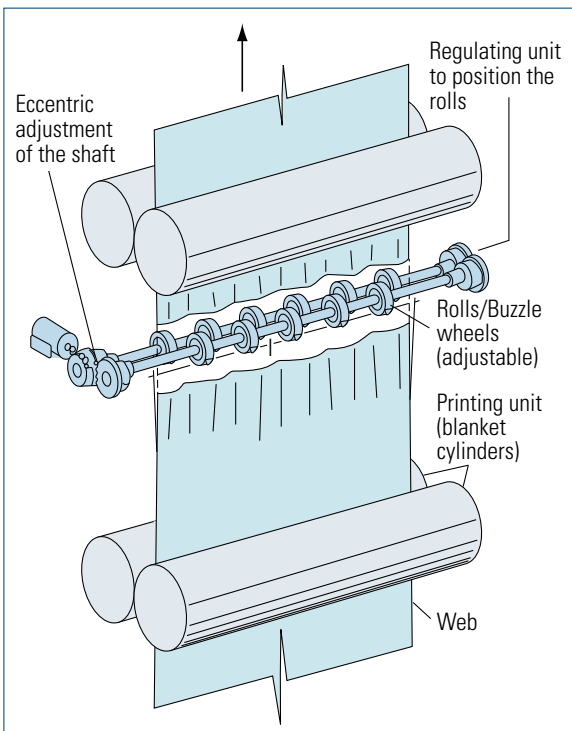
er problem, which could only be compensated for by the printing plates if they could be stretched laterally.

To compensate for the “fan-out” effect, the individual printing plates are arranged on the plate cylinder slightly off-center, that is, slightly less than the web is stretched by the fan-out effect. The fine adjustment is ensured by means of so-called buzzle wheels (fig. 2.1-99), which only allow the web width to be reduced. An optimal lateral register is thus achieved.

The “buzzle wheels” (fig. 2.1-99) in their simplest form are arranged on both sides of the web and are pressed into the paper web, thereby causing a waved deformation of the web. In more recent variants the buzzle wheels are driven at a lower speed, so that harmful effects reducing the product quality (e.g., ink set-off) and smearing are eliminated.

### Slitters

With double-width newspaper web offset presses, the web must be cut into two halves in front of the former or formers to create a common newspaper product. For



**Fig. 2.1-99**  
“Buzzle wheels” for lateral “web buckling” to compensate for the “fan-out” effect (TKS)

*tabloid products* printed on web offset presses, the web has to be cut to the former center (see fig. 2.1-113). In other words, the complete web is divided into a number of individual ribbons. However, any intervention on the web disturbs the web travel, as does slitting.

Slitting also involves the risk that the slitter might notch weak points into the paper, thus causing the web or the individual ribbons to tear. As is the case in metallurgy, a peak stress is exerted on the notches, which will cause the paper to tear even with the tiniest oblique line. Therefore, the web tension in the slitting knife area is sometimes reduced by installing controlled draw rollers that are set to low tension values in front of and after the slitters.

As far as slitter technology is concerned, there is a distinction to be made between shear cut-knives and blunt-cut knives (see fig. 7.2-9). To produce a shear cut, an upper and a lower knife operate like a pair of scissors, whereas the blunt cut is produced by a blunt knife pressing on a hardened smooth roller while the paper is running through between them. To produce a smoother cut with less serration, investigations are in progress to slit the web with high-pressure water jet or laser beam techniques. These methods are not yet in use.

### Turner Bar

Another element that might influence the web tension and the position of the web is the turner bar (fig. 2.1-100). Turner bars are used to route one slit half of the web (a ribbon) from one side to the other, or to turn a ribbon to achieve a varying page arrangement within the product (fig. 2.1-116a). To compensate for the loss of tension, controlled draw rollers are incorporated into the turner bar assemblies.

Blast air is circulated around the turner bars so that there is no friction and the ink does not offset on the turner bars and thus smudge the printed image. For the same reason, turner bars are chromium-plated. To circulate the blast air around the turner bars, the air is routed inside the hollow turner bar and then penetrates to the turner bar surface through very fine nozzles, that is, around those places where the paper wraps around the turner bar (fig. 2.1-100, see also fig. 2.2-20).

It has proved very useful to employ cantilever turner bars for fast paper infeed; this is on account of the greater accessibility.

### Former

The effect of a former (fig. 2.1-88) is the same as using two turner bars arranged at an angle to each other, so



**Fig. 2.1-100**

Turner bars for turning the web, changing web travel direction and position (Heidelberg)

that they taper towards the tip. In addition, this triangle is aligned at an angle to the web so as to gather the web halves running over the triangle sides at the tip, thereby producing a ribbon bundle that is folded lengthways. To reduce friction and ink set-off, the former flanks are cushioned by blast air. This is done by admitting blast air to the slim and hollow cylinder cores, and it penetrates onto the surface through very fine nozzles.

The former flanks are chromium-plated, as is the former plate enclosed by the former flanks, which is of minor importance for web guiding. The plate only serves to ease manual paper threading.

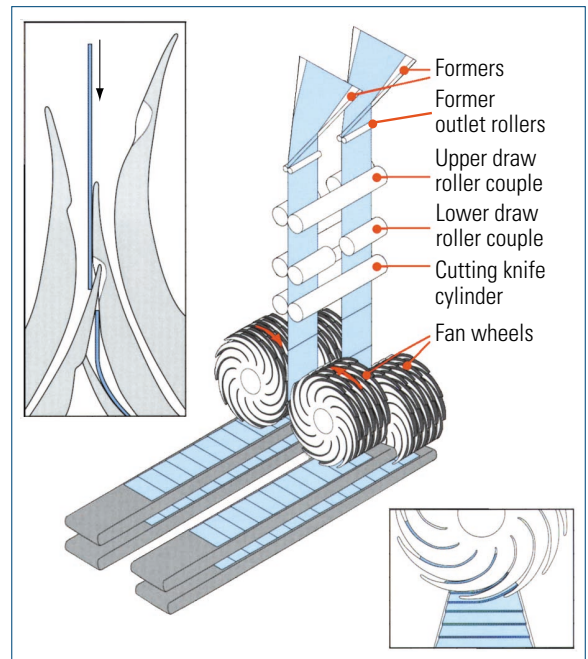
Another controlled draw roller is installed in front of the former, which has the additional task of merging the individual ribbons (see [fig. 2.1-88](#)); this is why this roller is also referred to as the roller top of former

(RTF). Different wrap angles at the RTF can result in heavy deviations of tension, and so present RTF configurations are mostly arranged in tandem, that is, behind one another, so that the bottom ribbon of the first roller will be the top ribbon of the second roller and so on. The former nose is flanked by two relatively thin, non-driven rollers, which support the gathering of the two ribbon halves.

### The Web Traction between Former and Folder

Two variable-speed draw rollers ([figs. 2.1-101, 2.1-89](#)) are arranged directly underneath the non-driven former outlet rollers. Earlier draw roller configurations consisted of just one roller and spring-loaded soft nip rollers resting on top. Today, real draw roller couples are employed, that is, there are roller bodies on either side, equipped with alternately meshing steel and rubber rings. These are also called “sandwich rollers” (see [fig. 7.2-24](#)). To stop the web from slipping on account of the high traction required by the ribbon bundle, two pairs are arranged at a time, one below the other.

The moment the ribbon bundle is cross-cut, the tucker blade cylinder of the folder (see [fig. 2.1-89](#)) needs to exert tensile strain on the ribbon bundle, which



**Fig. 2.1-101** Fan wheels dividing the product stream (Heidelberg)

means that the tucker blade cylinder is equipped with pull rings that are adjustable in their radial height in accordance with the pagination to be processed. The simplest configuration can only be adjusted at press standstill by lifting or lowering the pull rings via thread screws. With high-performance folders, the pull rings can usually be adjusted during press run. This requires complex planetary adjusting mechanisms on the cylinder shaft. The basic functions of the folder have already been described in [section 2.1.3.1](#), which also contains brief explanations on the cutting units, the pins and the gripper transport ([fig. 2.1-89](#)). The following paragraphs contain additional information of significance for the web or product transport.

### Cutting Unit

In newspaper and magazine printing, the ribbon bundle is usually cross-cut with a finely serrated knife working against a hard rubber strip. We are used to this serrated cut on newspapers, but on magazines and other commercial printed products it is trimmed off (three-sided trimming) in a subsequent finishing process.

Even with commercial web offset presses, shear-cut knives for the straight cut are rarely used nowadays, as the setting procedure is very complicated and they need to be constantly readjusted.

### Transportation with Pins or Grippers

Pins/needles are screwed onto the tucker blade cylinder and/or the collector cylinder ([fig. 2.1-89](#)) where the front edge of the section is located. The pins are barbed and are arranged in the form of a Christmas tree. The product or section of a product is pressed onto the needles so that the product is held on the cylinder surface. Naturally, this leaves needle punctures on the bottom margin of the product. These are tolerated in newspapers; in magazines and commercial print work they are cut off in a finishing process by trimming. For the transfer of the section to the jaw folder, the pins are retracted under cam control, thereby releasing the section from the tucker blade and collector cylinder.

The folder for gripper transfer requires a totally different design, comparable to the design of variable format folders on gravure printing presses. Unlike pin transfer, gripper transfer of the folded product/section requires a gap between the individual sections, so that the gripper can move down on to the section. This means that the cross-cut of the ribbon bundles cannot be performed between the cutting knife cylinder and

the tucker blade cylinder, but that the cutting knife couple must be located above this area.

### Fan Delivery

The fan wheel (see [fig. 2.1-89](#)) forms the shingle stream for the delivery and slows down the copies gently. This results in a wedge-shaped cross section of the fan wheel segments in the curved blades. For the finishing processes, products must have some degree of positional accuracy, and so the fan wheel needs to be equipped with adjustable discs serving as side limits and movable stops, which are attached to the fan wheel. Another option is to have the product collected by revolving grippers for a short period. [Figure 2.1-101](#) shows a special fan wheel configuration for distributing the product stream to two adjacent delivery systems.

### 2.1.3.3 Printing Unit

The term “printing unit” in this section encompasses the entire printing system with all associated functions – not only the part where the actual print is produced, that is, the transfer of ink onto the substrate. The printing system – especially in newspaper printing – consists of several individual subassemblies described in the following.

#### Impression Cylinder (Satellite Printing)

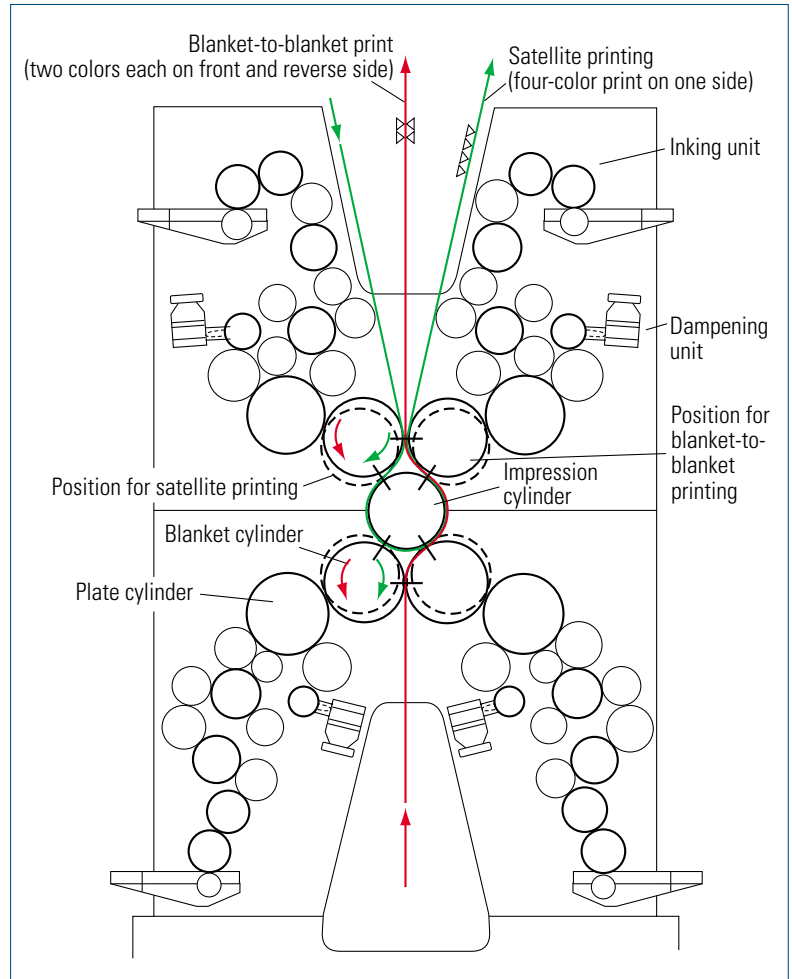
The satellite printing principle ([fig. 2.1-102](#)) has a common impression cylinder (also referred to as CIC) around which the printing units are arranged in a satellite configuration. One might describe the CIC as the “sun” of the satellite system. It is composed of a thick-walled steel cylinder with a hard chromium-plated surface that prevents the ink from offsetting. Its surface is very smooth and has no recesses, since it only serves to produce the counter pressure. The impression cylinder generally has double-row roller bearings to provide an easy-running and stable base and is driven by a helical toothed wheel. It has the simplest structural design in the entire printing unit. The printing unit shown in [figure 2.1-102](#) – a “combination satellite” – allows for printing of either four colors on one web side (satellite printing) or two colors on either side of the web respectively (blanket-to-blanket printing).

#### Blanket Cylinder (Blanket-to-Blanket Printing)

[Figure 2.1-103](#) shows the double printing unit of a web offset press. The upper and lower web sides are printed simultaneously, that is, “blanket-to-blanket” printing. The blanket cylinder transfers the image from the plate cylinder onto the substrate, thereby ensuring a

**Fig. 2.1-102**

Combi-satellite configuration for newspaper printing (MAN Roland)



high-quality print on account of its elastic (soft) surface.

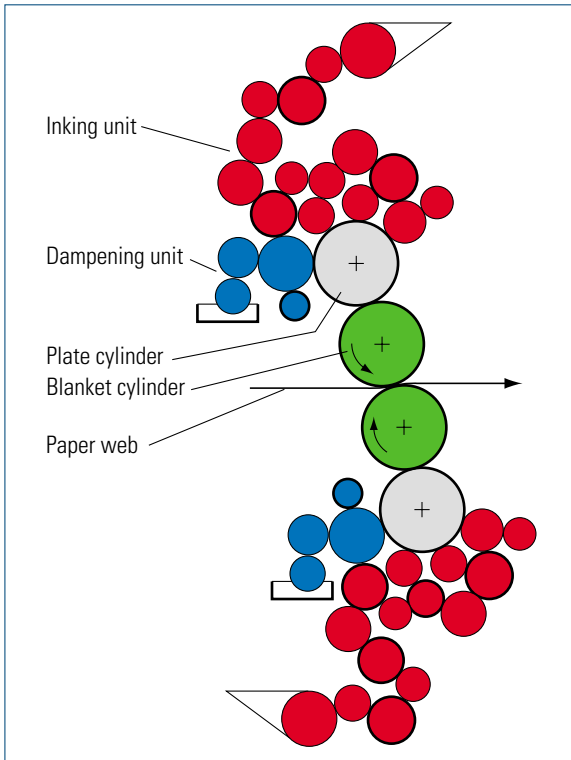
The cylinder usually has a thick nickel layer to prevent corrosion. The blanket is mounted on the cylinder and fixed into the cylinder gap with clamping bars. To attain the correct cylinder height, the blanket is packed with an underlay sheet. The bearer height serves as a reference line for height adjustment (the plate cylinder is also equipped with bearer rings). There are also presses without bearer rings; they are fitted with gauge rings on the blanket cylinder instead of bearer rings and where the gauge ring does not make contact with the opposite cylinder.

With blanket-to-blanket printing presses, the blanket cylinder – as the ultimate link in the inking unit

chain – is driven by the longitudinal shaft or has its own direct drive. For impression throw-on/off operation, the blanket cylinder runs on eccentric bearing-housings or on levers and is moved pneumatically or hydraulically. To provide for this mobility, the drive needs to be adapted. When shaftless drives are used, mobility is provided by toothed belts or hollow shaft motors located on the cylinder shaft. In the case of conventional shaft drives, the helical toothed wheels must always be engaged during throw-on/off operations.

With special configurations on high-speed web offset presses, gapless blanket sleeves (fig. 2.1-104) are employed instead of conventional blankets. Thanks to this technology, there has been both a considerable reduction in gap-induced vibrations and a high quality of





**Fig. 2.1-103**  
Blanket-to-blanket printing unit of a web offset press (M-600, Heidelberg)

print even at web speeds of up to 15 m/s (3000 fpm, which corresponds to 100 000 cylinder revolutions/h).

### Plate Cylinder

The plate cylinder carries the printing plate, which is also clamped inside a cylinder gap. The clamping mechanisms consist mainly of hook-like clamping flaps into which beveled edges of the printing plate are hooked. There are also simpler designs consisting of a thin beveled slit into which the plates are inserted and held in place by their own residual stress. The clamping mechanisms are mainly opened and closed by rocking levers that can be operated with a screwdriver-like tool located inside the clamping flap. The flap is spring-loaded to enable automatic retensioning. [Figure 2.1-105](#) shows an example of the plate clamping mechanism on a commercial web offset press.

So that the printing plates can be mounted in accurate register, the clamping bars are provided with regis-



**Fig. 2.1-104** Blanket cylinder sleeve (M-3000, Heidelberg)

ter pins that engage into the grooves on the printing plates. In newspaper printing, the single printing plates on one cylinder can be laterally adjusted to compensate for the fan-out effect caused by moisture on the paper.

Like blanket cylinders, plate cylinders have a thick nickel coating even though they are less exposed to corrosion on account of frequent plate change. The clamping flaps and the clamping mechanisms are usually made of stainless steel.

Circumferential and lateral register adjustments are integral components of the bearing and drive mechanism for the plate cylinder. The simplest method of carrying out a register adjustment would be to move the cylinder in the lateral direction and at the same time shift the helical gears against each other, thus causing the cylinder to turn in circumferential direction in accordance with the helix angle. However, in order to avoid the coupling of the circumferential and lateral register, adjusting mechanisms need to be kept apart. This is achieved through somewhat complex mechanisms.

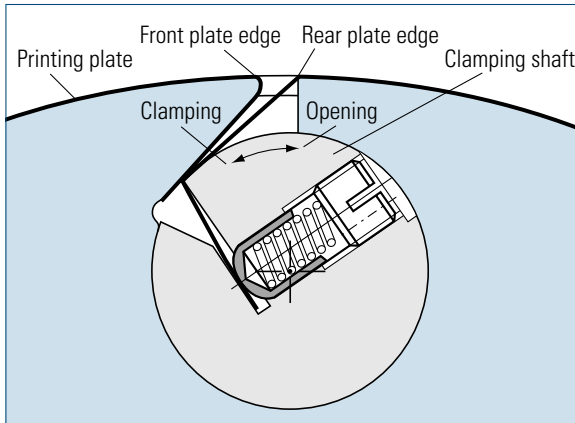


Fig. 2.1-105 Plate clamping mechanism (M-600, Heidelberg)

### Inking Unit

Basically, the main differences between the designs of inking units for web offset and sheet-fed offset presses result from speed requirements and the paper qualities being processed. Substrates in sheet-fed offset presses run at a speed of up to 5 m/s while the web in web presses can travel at a speed of up to about 15 m/s. Generally, higher-quality paper is used for sheet-fed offset presses in order to ensure high-quality printing.

Inking units in web offset presses, and in newspaper presses in particular, differ from inking units in sheet-fed offset presses in their continuous ink supply, that is, the inking units have no cycled vibrator rollers. Instead, “continuous-feed inking systems” are used. The fast-running film roller is installed near the slow-running fountain roller. It takes the top ink film layer off the fountain roller. The relatively thicker ink film is produced by an ink fountain blade, which can be adjusted in zones (see sec. 2.1.1.3).

Another distinguishing feature is the way the ink fountain blades are arranged. There are designs where the fountain blades are either located at the top (overshot) or bottom (undershot). In addition, the inking units for web-offset presses and sheet-fed presses differ in the number of ink form rollers; that is in the storage volume of the inking unit. Whereas sheet-fed offset presses need four ink form rollers (in some cases even five) to achieve even plate inking, web offset presses usually do not need as many rollers to achieve even inking of the plate; this is due to the simple inking-unit dynamism resulting from the smaller gap. Three ink form rollers suffice for commercial web

printing (fig. 2.1-103), and for newsprint even plate inking is achieved with just two form rollers. Occasionally, distributor (rider) rollers are placed on top of the ink form rollers to achieve an even and smooth ink application profile.

The roller train between ink fountain and the ink form rollers consists of driven and oscillating distributor rollers, which usually have a Rilsan (polyamide) coating and non-driven rubber rollers. In the last few years, many optimization calculations have been made for roller arrangement, varying diameters, and separate ink flows. The ink flow on the inking unit shown in figure 2.1-103 can be set (fig. 2.1-106), that is, the three ink form rollers transfer different portions of the ink onto the printing plate. At a 100-0-0 setting (fig. 2.1-106), the first ink form roller transfers all the ink onto the plate, while the other two rollers merely smooth and even out the ink layer. With an 80-10-10 setting, 80% of the whole ink is supplied by the first form roller, whereas only 10%

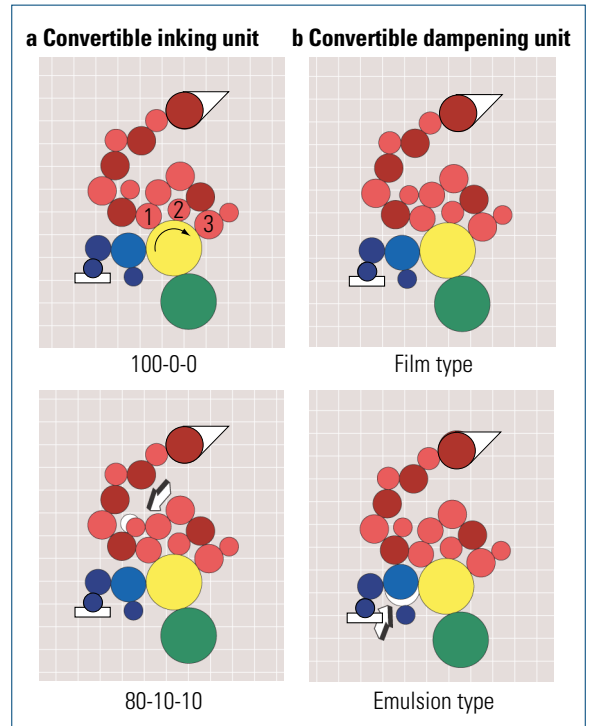


Fig. 2.1-106

Inking unit with changeable ink and dampening solution flow.

a Inking unit change-over;

b Dampening system change-over (M-600, Heidelberg)

is added by the second and also the third roller respectively. This is regarded as the basic setting.

Due to the high speed and roller set-up on web offset presses, the roller locks for the removable rubber rollers and the throw-on/off mechanisms for ink form rollers are designed differently to those for sheet-fed offset presses. Furthermore, the inking unit on web offset presses might need to be equipped with special devices and rail systems for changing rollers, on account of their great weight.

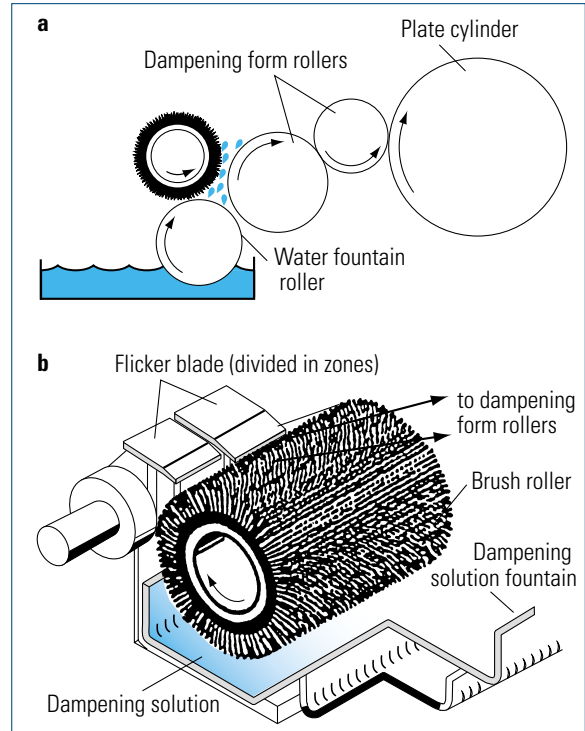
### Dampening System

There is a large variety in dampening system designs, not to mention the fundamental categorization into contact and non-contact dampening systems, that is, the dampening solution is sprayed onto the plate surface or applied via the roller train. Spraying is the preferred method in newspaper printing today, as the dampening solution is not soiled by the transfer of dirt particles from the plate and the ink form roller into the dampening solution fountain. Higher quality requirements (more finely metered dampening solution) mean that contact continuous-feed inking systems are being used in commercial web offset printing.

The dampening solution distribution in non-contact dampening systems (figs. 2.1-107 and 2.1-108) is based on the following operating principles:

- brush-type dampening systems with water fountain roller (fig. 2.1-107a),
- brush-type dampening systems with immersing brush (fig. 2.1-107b),
- catapult dampening systems with rotor (fig. 2.1-108a),
- jet-spray dampening systems (fig. 2.1-108b), and
- turbo dampening systems (spiral roller, see fig. 2.1-15e).

Brush-type dampening systems with a water fountain roller collect the dampening solution film from the fountain roller revolving in a water bath and then catapult it onto the dampening form roller by holding back the bristles and releasing them suddenly (fig. 2.1-107a). With the second variant of brush-type dampening systems, the brush is immersed directly in the water, and it absorbs the water with its bristles; the water is then catapulted onto the dampening form roller by a flicker blade divided into zones (fig. 2.1-107b). Since there is no direct contact between dampening form rollers and brushes, dirt particles cannot get into the dampening solution fountain.



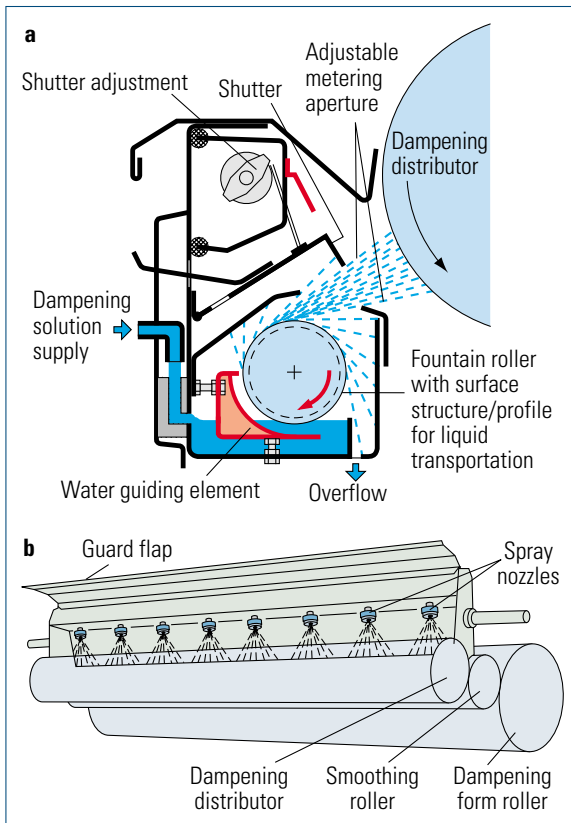
**Fig. 2.1-107** Brush-type dampening system.

**a** Brush for catapulting the solution from the fountain roller onto the form roller;

**b** Brush for conveying and catapulting the solution via flicker blades (IFRA)

This catapulting process can be done in many different ways. In addition to brush-type dampening systems, dampening systems with catapult rotor disks, spiral rollers or fountain rollers with special surface structure/profile and jet-spray systems have been developed (figs. 2.1-108 and 2.1-15).

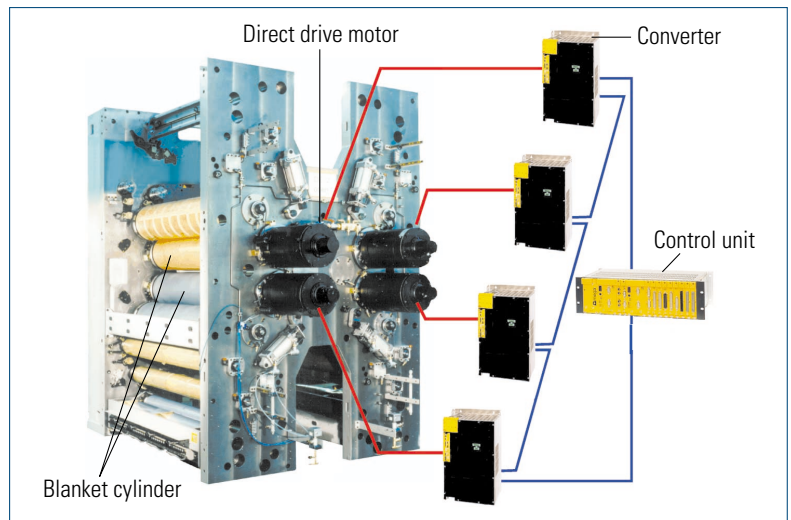
Jet-spray dampening systems are used very often, as they are easy to exchange. They consist of a pipe with jets. The spraying interval and duration is controlled by a solenoid valve. This requires the dampening solution to be pressurized in a suitable pump. The spray nozzles produce a wide jet cone and the nozzles are located at some distance from the dampening form rollers, so that the neighboring jet cones overlap only slightly. In this way, homogeneous application of dampening solution over the entire width is ensured. Figures 2.1-103 and 2.1-106 show examples of printing units equipped with a contact dampening unit. Figure 2.1-106 shows a convertible dampening unit where the



**Fig. 2.1-108** Non-contact dampening systems.  
**a** Catapult/centrifugal dampening system (MAN Roland);  
**b** Jet-spray dampening system (Jimek-Graphotec)

**Fig. 2.1-109**

Direct drive of a blanket cylinder in a newspaper printing unit (Baumüller)



application of dampening solution is independent of the ink flow (film type) or coupled to the inking unit (emulsion type).

### Individual Drive (shaftless/gearless)

In the last few alternating years, advances in current servo-motors with fast data communication for frequency control of the motors have made it possible to eliminate mechanical shaft couplings or gear wheel meshing between the cylinder groups in the printing unit and, consequently, to drive such cylinders as blanket cylinders directly (fig. 2.1-109). For reasons of cost, other cylinders are coupled via gears in order to be driven by the same motor.

It seems rational that the motors themselves can act as actuators for the circumferential register adjustment.

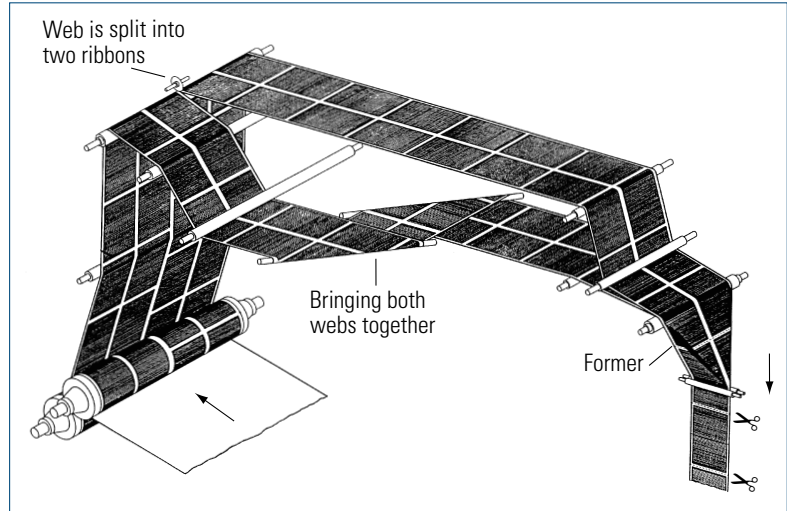
Control engineering for these sorts of direct drives originates from machine-tool manufacturing and, for the most part, is supplied to the printing press manufacturer by its subcontracting industry. There are no substantial differences between individual makes because the machine-tool manufacturing industry agreed to generally binding standards (e.g., SERCOS-Serial Realtime Communicational System) at an early stage.

### 2.1.3.4 Folders and Print Product Variations

Folders are the bottle neck of a flow line production in web offset printing. The definition of a folder should include the folder superstructure (fig. 2.1-110, see also fig. 2.1-87) insofar as it is involved in forming the prod-

**Fig. 2.1-110**

Folder superstructure on a newspaper rotary printing press (IFRA)

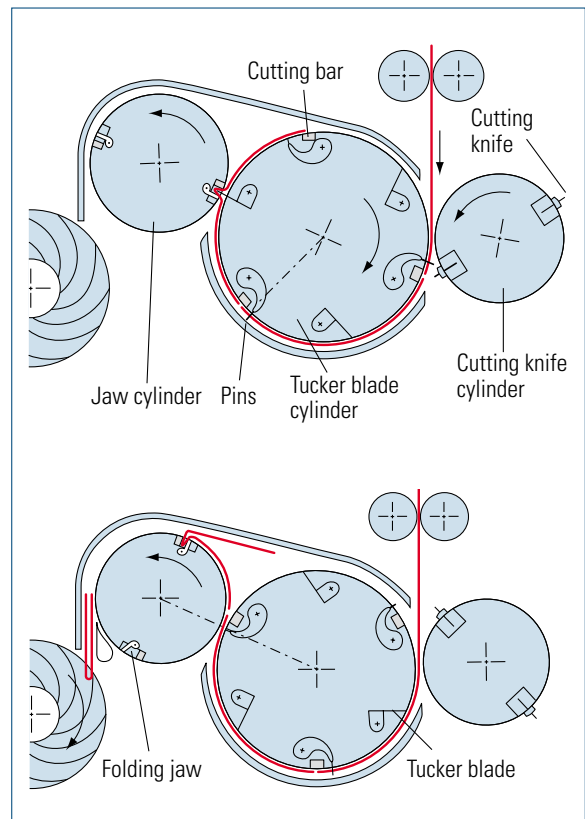


uct. If the folder itself is meant, it is referred to as the “cylinder section of the folder”.

### Jaw Folder

The jaw folder is the cylinder section of a folder most commonly used in commercial web offset presses and newspaper web offset presses. The web running out of the former consists of several layers and is normally closed on one side; it is first routed into the cross-cutting section (fig. 2.1-111). This cross-cutting section has a two-piece cutting knife cylinder operating against a three-piece tucker blade cylinder equipped with three cutting bars of elastic and resistant material. The cutting knife is serrated like a saw and performs a cut that leaves the sheet edges serrated, too. With commercial print jobs, these edges are later cut off with a straight trim cut. However, as far as newspaper products are concerned, the serrated cut is regarded as a product-specific characteristic.

The real distinguishing feature of a jaw folder, however, is the type of fold performed by the tucker blade and folding jaw. To this end, the three-piece folding cylinder and a two-piece jaw cylinder act together after the cut has been performed (fig. 2.1-111). The folding cylinder must be divided into three segments, or any other odd number of segments. The reason for this is that with collect-run productions, the two product sections arranged in tandem on the folding cylinder are placed on top of each other to ensure that a first section is always joined to a second section and not the same product sections. For products with higher pagi-

**Fig. 2.1-111**

Jaw folder. Interaction between cutting knife, tucker blade, and jaw cylinder (IFRA)

nation and for higher production speeds, five-segment and seven-segment folding cylinders are also used.

The jaw fold is produced by the cam-controlled tucker blade moving out of the cylinder when the tucker blade and jaw cylinder come into contact, thereby pushing the cut ribbon bundle into the cam-controlled open folding jaw. At this point the folding jaw, which consists of a spring-loaded steel rail with counter-rail, closes immediately and retains the product, while the cylinder continues to run. While the following product half is steadily transferred over from the folding cylinder to the jaw cylinder, the advancing product half must be pulled tangentially over the wedge formed by the two cylinders. This whip-like movement is the crucial point in jaw folder design. Specially shaped guiding elements or cushioning brushes are used to stop the product from being damaged.

The jaw cylinder can be segmented into two parts. Due to the fold being produced, only two quarters of the cylinder at a time are covered with products. To facilitate setting operations for precise interaction between the tucker blade and the folding jaw, the jaw cylinder and the folding cylinder are segmented equally, that is, the same tucker blade always engages in the same folding jaw. This is referred to as a 2:3:3, 2:5:5, or 2:7:7 folder where the segmentations of the cutting knife cylinder, the folding cylinder, and the jaw cylinder are shown with their respective segment ratios.

On completion of the folding process and half a turn of the cylinder, the folding jaw opens again, and this is also a cam-controlled operation. Separator elements engaging in the cylinder grooves remove the product from the cylinder surface and allow it to drop into a fan wheel by means of gravity and centrifugal force, with the folding spine ahead. The product is then slowed down and delivered in a shingled stream.

### Gripper Folder

On the jaw folder described above, the product is transported over the cylinder by pins (see [fig. 2.1-111](#)). For many applications, pin holes on the product are not acceptable. The pin holes are tolerated on newspapers if they are at the bottom of a newspaper page. (On Japanese and Chinese newspapers, which are read from the back to the front, the former incline needs to be the other way round; otherwise the pins would be at the top of the newspaper.) To avoid pin holes altogether, gripper folders are used.

Since there must be a gap between successive sections so that the grippers can pick up the sections, the cutting knife cylinder cannot intermesh directly with the fold-

ing cylinder, but has to be provided with its own cutting counter-cylinder which is located in front of the folding cylinder. Upon cutting, the product section is accelerated for a short time by conveyor belts, thus creating the gap to the next section. The front end of the product is transported into the open grippers of a gripper bar. Subsequently, the grippers are closed by a cam disk. The grippers are designed and controlled in such a way that they leave no mark on the product. The grippers are spring-loaded, and their contact surfaces are roughened to ensure reliable transport over the cylinders despite the relatively low clamping force. The successive folding procedures correspond to those on a jaw folder.

### Drum Folder

The drum folder, also called a “rotating folder” ([fig. 2.1-112](#)), works on a completely different folding principle compared to other types of folder. Apart from a cutting knife cylinder, the drum folder is equipped with a folding cylinder that pushes the ribbon bundle between two folding rollers using the folding/tucker blade. As the tucker blade has to travel a long way, the operation cannot be cam-controlled but works with a special planetary gear. The successive product sections are simultaneously gathered on the folding cylinder (gathering), which requires the cylinder to make two revolutions together with the product. To stop the tucker blade from coming out three times and possibly damaging the products, the folding cylinder needs to be specially designed.

The tucker blades are mounted in a second, smaller cylinder that is eccentrically supported in the actual folding cylinder. This means that the rotating tucker blades cut twice into empty space, that is, in the gap between the eccentric inner cylinder and the outer cylinder, which carries the product sections. Only at the very bottom, where the two folding rollers are directly opposite the cylinder, do the tucker blades come out of the outer cylinder periphery. At the same time as it is pushed between the folding rollers, the product is seized by knurled nip rings on either edge of the folding rollers, and the fold is performed. Every so often knurling can leave marks on the product margin.

The particular problem with this fold type is the vast acceleration in the direction of the folding rollers. Reliable folding without damage is achieved by specially shaped guiding elements and cushioning.

### Former Fold

The former fold is the folding unit located in front of the cylinder section of the folder. Unlike the sudden

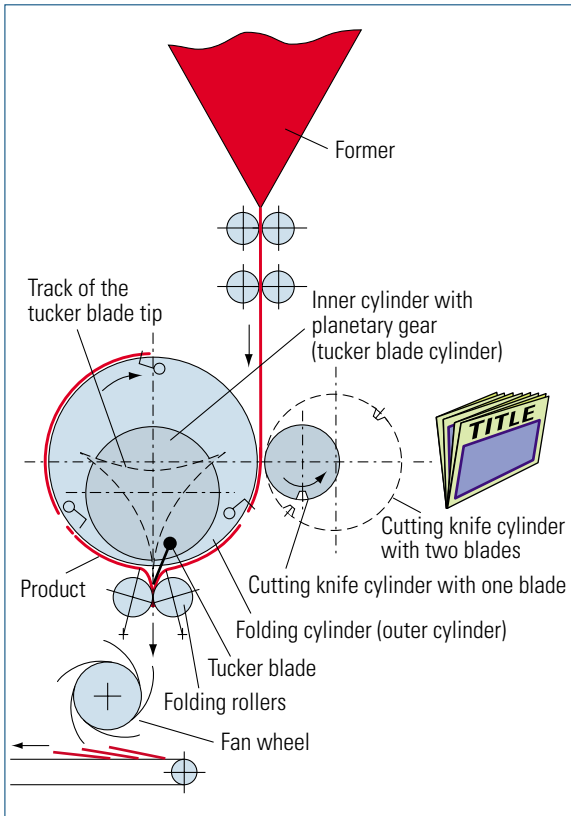


Fig. 2.1-112 Drum folder (IFRA)

cylinder fold, the former fold is a continuous-flow fold. The web or the ribbon bundle is directed in the shape of a bag around two former flanks that are at an angle to one another (approximately  $60^\circ$  to  $70^\circ$ ) and inclined in the travel direction of the web. In this way the longitudinal fold is performed at the former nose (for details, see secs. 2.1.3.1, fig. 2.1-88 and 2.1.3.2).

Single-width presses are usually provided with one former, whereas double-width presses have two formers (fig. 2.1-113). As the number of formers determines the number of possible sections/parts of a product (for example a newspaper), more than two formers are sometimes used. Three formers are used adjacently by guiding one half of the web via parallel turner bars to the third former outside the web track. Four formers used one pair on top of the other pair are called “balloon formers” (fig. 2.1-114). There are also configurations where there are three levels with two formers each arranged on top of one another, for the production of

up to six sections per product or even twelve sections in collect-run production. A *section* is the part of the product that has the same spine, that is, former fold. These sections are also called “books.” To achieve various combinations, the ribbon bundles of these books can be transported along different routes from the balloon formers to the cylinder section.

### Cross-Fold, Parallel Fold, Delta Fold

The cross-fold has already been described in the beginning of section 2.1.3.4. There are different variants of this type of fold to increase the product variety of commercial web offset presses in particular.

By fitting a second smaller folding jaw cylinder on the periphery of the folding cylinder that folds the product in the middle prior to the cross-fold a paral-

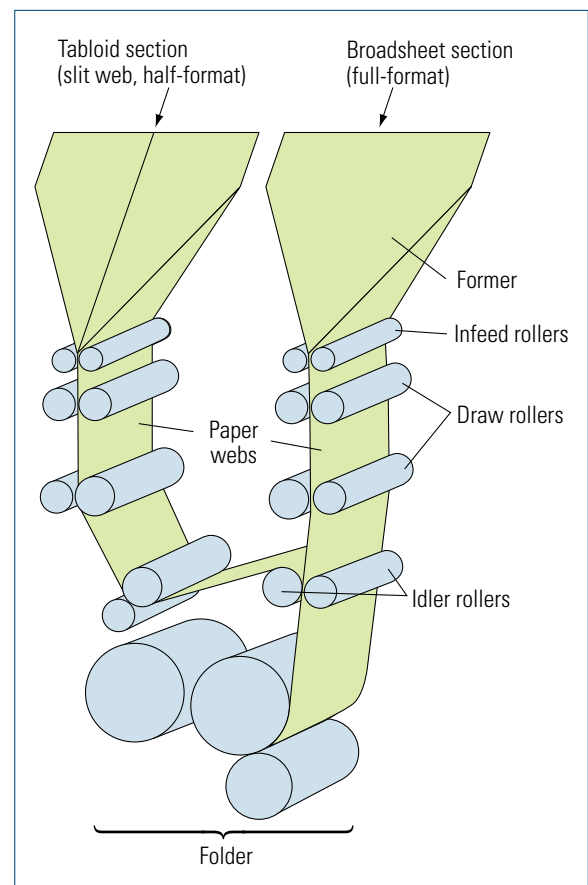
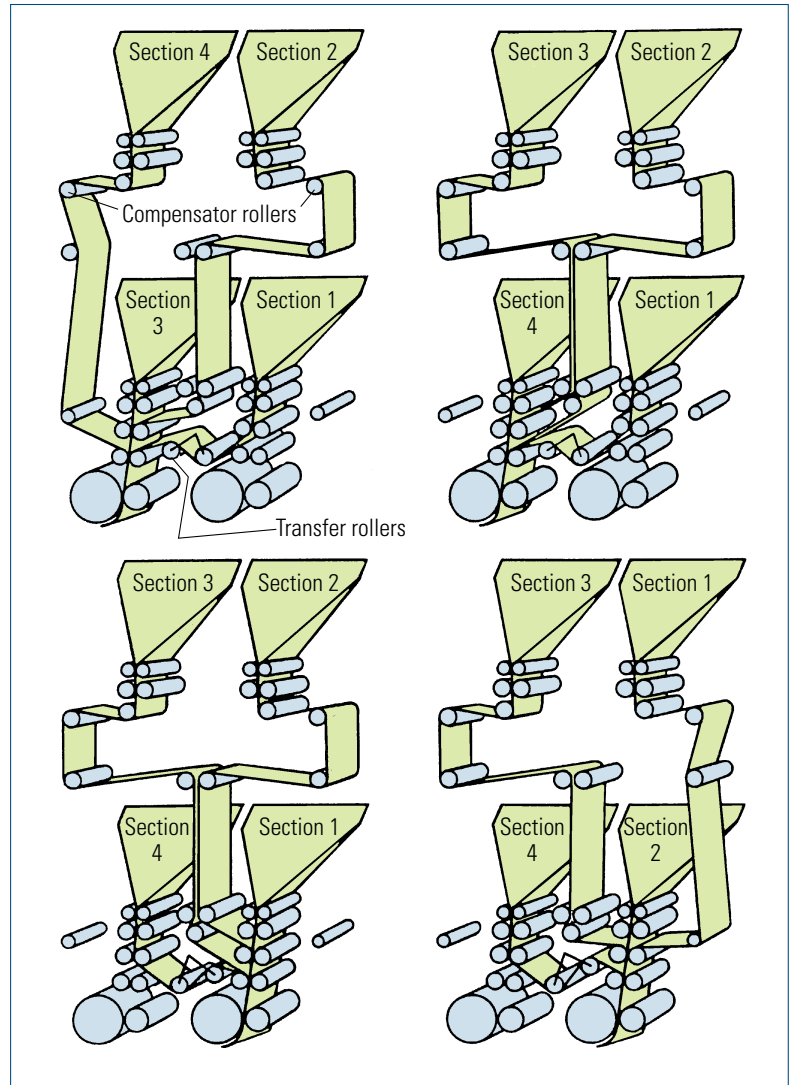


Fig. 2.1-113 Formers arranged in parallel for web gathering (IFRA)

**Fig. 2.1-114**

Balloon former; former combination for the production of ribbon bundles (IFRA)



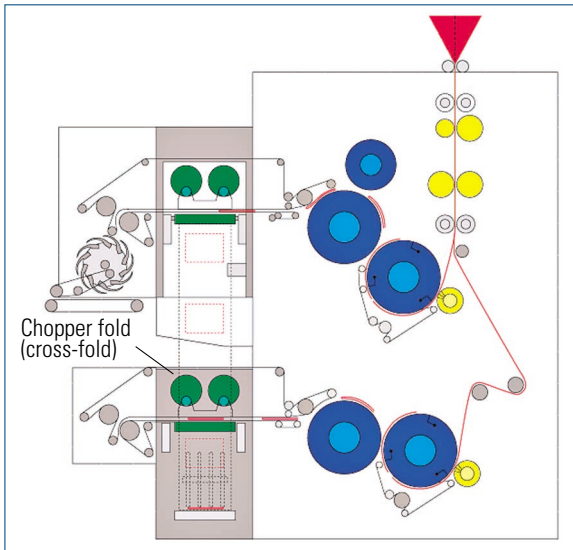
lel fold product used, mostly for products of paper-back size, is produced. In this way, two products are formed in one production flow. They are still connected at their head and are separated later in a finishing process.

A square product or “delta fold” is produced if the small auxiliary jaw cylinder is positioned within the first third of the product lying on the folding cylinder. Folded products of this kind are very popular in advertising. This shows how versatile the fold types can be, even with a folder that is otherwise a fixed-size folder or fixed-size web offset press.

### Quarter Fold

The “quarter fold” (also called chopper fold, third fold or second longitudinal fold) describes the fold performed after the former fold (first longitudinal fold) and the cross-fold (the second fold). The folding principle used for the quarter fold is similar to the folding principle used in the drum folder (fig. 2.1-112). A rotating tucker blade pushes the product sections between two folding rollers performing the fold. Figure 2.1-90 shows the quarter fold as a variant. Figure 2.1-115 shows a configuration to produce the third fold. It becomes clear that production is possible with or without the





**Fig. 2.1-115** Folder with two quarter fold (chopper fold) units with several delivery and folding variants (IF-50ST, Heidelberg)

chopper fold and with two web ribbons on two different fan wheels or delivery belts. To increase throughput and also to split the product stream, the product sections are routed onto two different “chopper fold

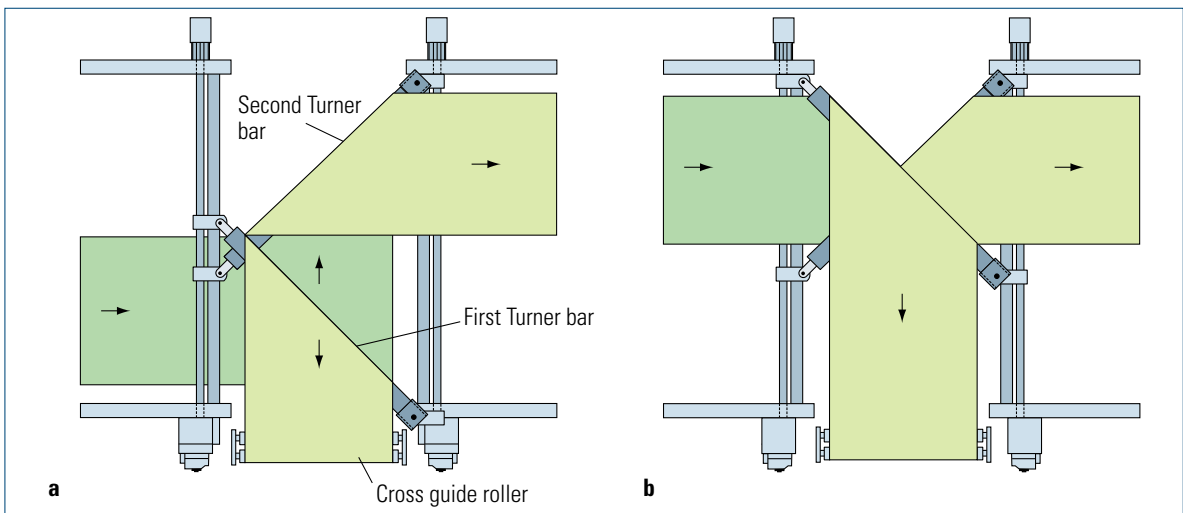
tables” by means of controlled diverters. In this way the folding speed can be halved.

Apart from problems caused by acceleration during folding and the risk of “dog ears” at open product edges, there is also the problem of product creasing, which results from air getting trapped in the closed product spine. To overcome this difficulty, the ribbon bundle is perforated longitudinally in the folder superstructure or moved against a sharp stop knife on the chopper fold table, which slightly slots the folding edge so as to remove trapped air.

When two quarter fold units are connected in series this is referred to as the “Swiss postal fold”. This fold is used to produce a “pocket-sized” newspaper.

### Turner Bars

Turner bars (see also [sec. 2.1.3.2](#), [fig. 2.1-100](#)) are used to position one half of a web on top of the other half, thereby producing a ribbon bundle that can be fed into a former. Two turner bars are required for this operation: one turner bar to deflect the web half at right angles, and another one to redirect the web half at right angles to the travel direction of the web, however shifted in the track ([fig. 2.1-116a](#)). [Figures 2.1-116a and b](#) show how the web is reversed by means of two turner bars and a cross-roller located in between. (These are also called “pony turner bars”).



**Fig. 2.1-116** Turner bar configuration.  
**a** Arrangement for moving and turning the web;  
**b** Arrangement for turning the web (MAN Roland)

In addition, one half of the web can be returned in the reverse direction to be printed on the reverse side in another printing unit, that is, to produce perfecting jobs with a double-width printing unit on a single-width web.

### In-line Finishing

“In-line finishing systems” with their own supplier industry have extended product variety even further. Devices supplied include plow fold tools for longitudinal folds where two ribbon halves are placed on top of each other and a longitudinal fold is produced. These plow fold tools work like formers, with the difference that the fold is produced on a web travelling in a straight line. This tool is mainly used with narrow ribbons, which makes possible a non-supported web guide. Other in-line finishing equipment incorporated in the superstructure includes cutting and perforating devices, window-cutting, and pattern-gluing machines, in addition to gluing machines for self-adhesive glue coating.

### Stitchers

Single sheets can be bound/held together either by an in-line application of glue or by stitching the product together with wire staples. High-performance stitchers (see also [fig. 7.2-75](#) and [table 7.2-22](#) in [sec. 7.2.5.5](#)) are incorporated at different positions in the production line, depending on the type of production.

High-performance stitchers operating at full production speeds are incorporated in the folders (e.g., as shown in [fig. 2.1-89](#)). The cylinder stitcher works together with closing heads that are fitted on the tucker blade cylinder.

The stitcher itself consists of two or three revolving closing heads with shaping wheels that shape the automatically fed staple wire into U-shaped staples after it has been cut. When the product comes into contact with the folding cylinder, that is, with the closing heads mounted on the folding cylinder, the cam-controlled stitching heads drive the staples through the ribbon bundle onto the closing heads, which automatically bend the staple legs over to secure the product.

This type of stitching is especially used for tabloid products. As shown in [figure 2.1-113](#) (left part), in tabloid production, the web is halved on the folding former, the halves being placed on top of each other, which means that two streams are fed to the folder even if there is only one former.

In addition to cylinder stitching machines, there are also ribbon stitchers that are used to staple quarter fold

products (first longitudinal fold, cross-fold, second longitudinal fold; see also [fig. 2.1-90](#)) for double production (two copies per revolution of the plate cylinder). They are integrated in the folder superstructure after the first longitudinal fold. The product is stapled in the longitudinal direction employing the ribbon stitcher, which operates together with the closing head cylinder.

### 2.1.3.5 Newspaper Printing

Compared to commercial web offset printing, newspaper printing features several distinguishing characteristics, mainly concerning the design of the printing unit.

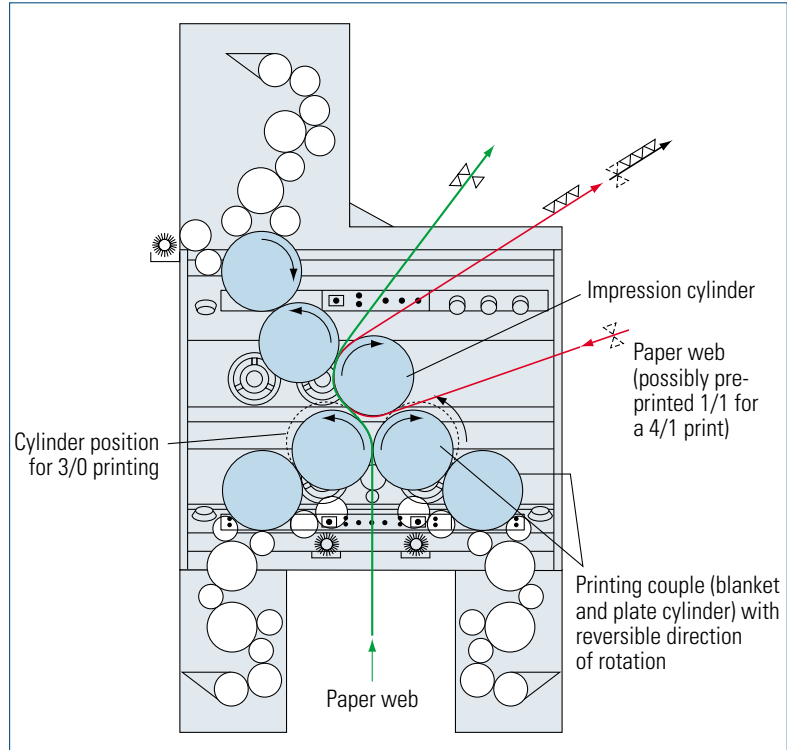
#### Vertical and Horizontal Printing Unit

Today, commercial web offset presses usually feature the vertical blanket-to-blanket printing unit with *horizontal web lead* (cylinder groups, plate and blanket cylinders of the printing units for top and reverse side of the web are arranged almost vertically, [fig. 2.1-84](#)), since the satellite design of earlier magazine presses did not, on account of their rigidity and size, prove successful. Occasionally, the satellite design is used in newspaper printing, however, the horizontal web lead and its inaccessibility are problematical for multi-web production used in newspaper printing because of the large number of pages involved. For this reason, *vertical web lead* is favored in newspaper printing, and this has led to the development of the horizontal printing unit, also called “*U-type or arch-type printing unit*”, with the cylinder groups for either side of the web arranged in the horizontal position ([fig. 2.1-120](#)), that is, turned at an angle of 90° as compared to the vertical printing unit ([fig. 2.1-103](#)).

#### Three-Quarter Satellite

The “three-quarter satellite” ([fig. 2.1-117](#)) was developed in the United States to produce color print jobs on preprinted webs. The three-quarter satellite has three printing couples arranged around a common impression cylinder, where one of the printing couples makes possible a change of rotational direction (in [fig. 2.1-117](#) this printing couple is located at the bottom right). Together with an adjacent printing couple, a 3/0 job can be printed; however, the printing unit alone can also be operated on its own to print a 2/1 job. This flexibility and the rare need for four-color prints are both reasons for not opting in the first place for a complete satellite configuration (e.g. the combi-satellite illustrated in [fig. 2.1-102](#)).

**Fig. 2.1-117**  
Three-quarter satellite (GOSS)



### Y-Type Printing Unit

The Y-type printing unit is a simplified version of the three-quarter satellite (fig. 2.1-118). In this configuration there is no common impression cylinder and no way of reversing rotation. The three blanket cylinders are arranged in such a way that one blanket cylinder is also the impression cylinder for the two other blanket cylinders. Figure 2.1-118 shows the three possible variants of web travel. For 3/0 jobs, the third color is printed in a “di-litho process”, that is, directly from the plate onto the paper web.

### Combi-Satellite

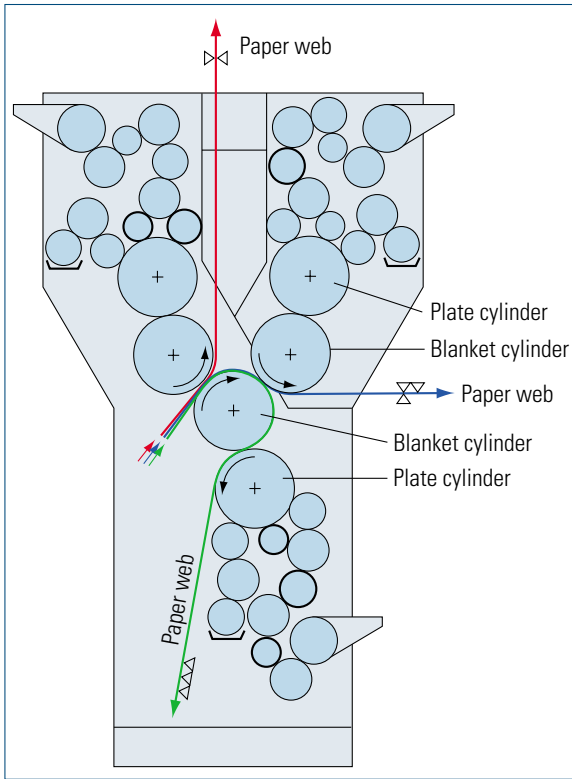
With a view to flexibility regarding the choice of 2/2 jobs and the capacity thus to process two webs in one printing unit without having to “tear apart” the four printing nips in one color set, the combi-satellite (fig. 2.1-102) has been developed. The four blanket cylinders arranged around the common impression cylinder can be repositioned so that printing takes place either in satellite mode (i.e., rubber to steel) or the blanket-to-blanket mode. This, of course, requires at least two printing couples to be reversible. To be able to produce

4/0 jobs in addition to 0/4, all four printing units are very often reversible in the direction of rotation.

Strangely enough, two different designs have developed over the years: vertical web travel and horizontal web travel, both regarding the blanket-to-blanket mode. It is difficult to say why this has happened. It actually only makes sense for twin satellites (see fig. 2.1-121), in that this creates an open gap for installing a cleaning device for the second impression cylinder. This alternative structural design was, however, developed long before the twin-satellite design – and, moreover, in the selfsame printing press manufacturing company.

### Semi-Satellite

The semi-satellite or “ten-cylinder satellite” (fig. 2.1-119) is a special type of combi-satellite. The common impression cylinder is divided into two impression cylinders. (There are three different designs: the vertical design with a vertically travelling web printing blanket-to-blanket, the horizontal web travel design printing blanket-to-blanket, and the sitting design with the blanket cylinder extended at the bottom for greater accessibility.)



**Fig. 2.1-118** Y-type printing unit (KBA)

### “Color Deck”

The term color deck goes back to the time when newspaper printing units could only print monochrome, and “color decks” were installed above the actual printing units to imprint spot colors (see also [figs. 2.1-200](#) and [2.1-201](#)). Since a satellite printing unit (see [fig. 2.1-102](#)) is only suitable for four-color prints on one side, color decks were also used at a later date to print a web on both sides in one printing unit. The color decks were mostly constructed as a U-shape printing unit consisting of two printing couples, either with or without their own impression cylinders or else with a common impression cylinder. In this way it was possible to add 1/1 or 0/2 prints to the four-color prints or to webs with a spot color.

### Four-High Unit

Four-high units were developed in the second half of the 1980s in response to an ever-rising number of different printing unit configurations available on the market, as a kind of “renaissance and back-to-nature

movement.” Four-high units are the simplest and the most compact method of producing a 4/4 job with one single printing unit. Here, too, two variations are available:

- four-high units consisting of two H-type printing units ([fig. 2.1-120](#)) arranged on top of each other (the H-type printing unit consists of an arch-type printing unit and a U-type printing unit) or
- four-high units consisting of four arch-type printing units arranged on top of each other. The latter has mainly been developed for printing units with keyless inking units to ensure equal geometrical ratios in all printing units.

To control lateral register deviations, the printing plates in four-high units must be laterally staggered to compensate for the expected “fan-out” effect (the web is laterally extended under the influence of dampening solution from the offset dampening unit). Minor corrections during printing can be carried out by anti-fan-out controllers, known as “buzzle wheels” (see [sec. 2.1.3.2](#) and [fig. 2.1-99](#)).

### Twin Satellite

Twin satellites ([fig. 2.1-121](#)) have been developed to produce 4/4 prints with a single printing unit, but without any fan-out effect. Since there are so many different types of satellites, combi- and semi-satellites, twin-satellite designs have proliferated accordingly. However, modern systems are mainly offered without conversion, that is to say, we should no longer really talk of combi-satellites.

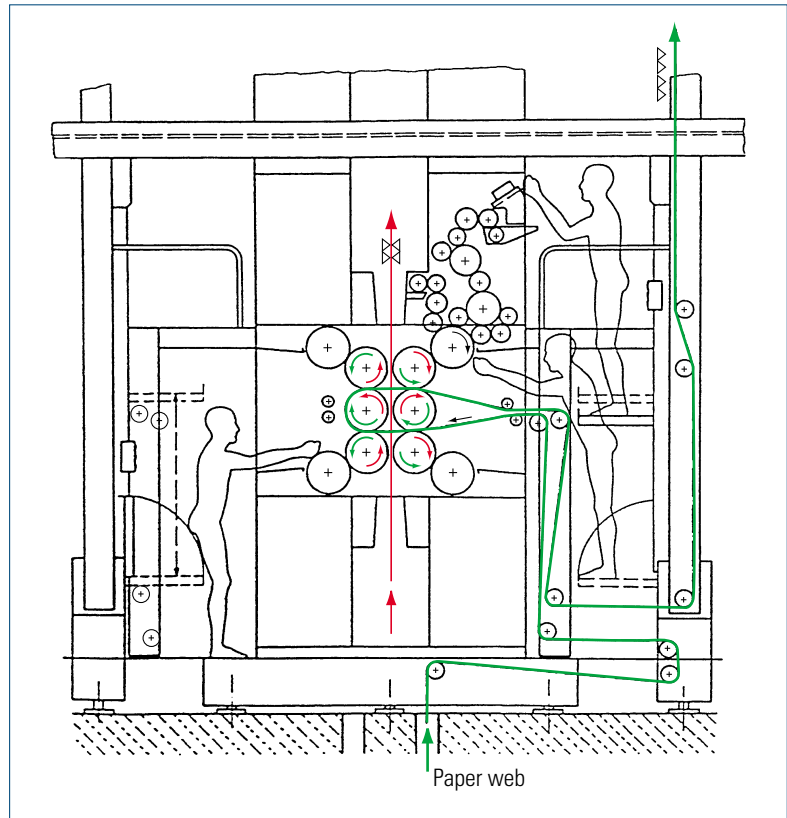
Twin-satellite designs are mainly used in Europe. In the United States, Asia, and Australia, four-high unit construction is still preferred.

### Dampening Systems

With dampening systems in newspaper web offset presses, linting (i. e., fast soiling of the dampening solution) is an issue. As a result, there should be no reverse transfer of dampening solution to the water fountain with these systems. Hence, all dampening systems used in newspaper printing feature non-contact design. At the beginning, brush-type dampening systems were predominant. They were equipped either with an immersing brush or with a brush that was in contact with the water fountain roller ([fig. 2.1-107](#)). There is also a kind of “spiral roller” in the form of a turbo-dampening unit. However, jet-spray dampening systems are

**Fig. 2.1-119**

Semi-satellite (10-cylinder satellite) with vertical web travel and blanket-to-blanket printing (WIFAG)



used nowadays for the most part, due to their easy maintenance (see also [fig. 2.1-108](#)).

### Keyless Inking Units

For thirty years, newspaper printing has been doing pioneering work in the field of keyless inking units. Solutions have been worked out that basically remove the residual ink film or the inhomogeneous ink relief from the ink form roller completely and apply a new homogeneous ink film. Until today three different designs have been used in practice ([fig. 2.1-122](#)):

- keyless inking units with Anilox (screen) rollers, that is, engraved, or structured metering rollers with doctor blade ([figs. 2.1-122a and b](#));
- with pick-up roller and scraper blade ([figs. 2.1-122d, e and f](#));
- with oscillating doctor blade ([fig. 2.1-122c](#)).

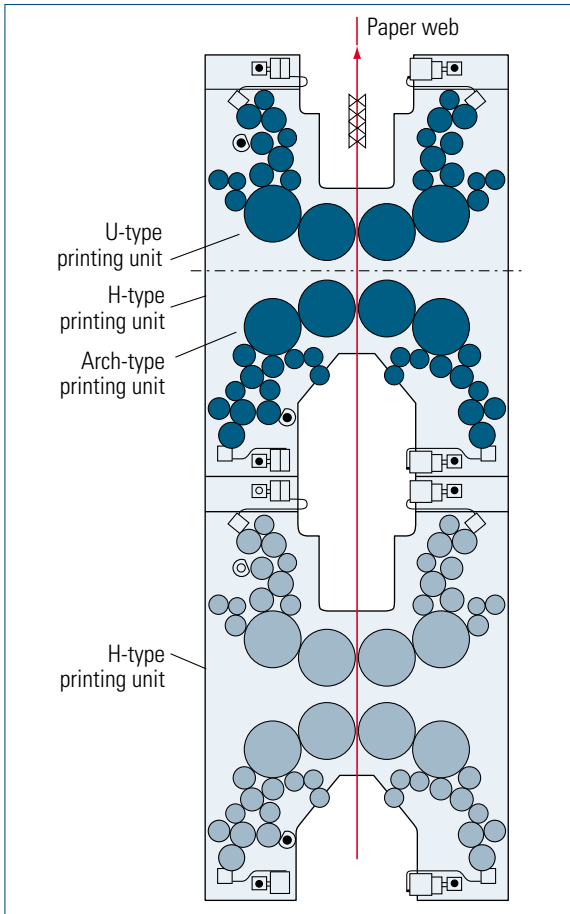
The second and the third designs enable a positive ink-feed, but in the case of the first design this needs to be

achieved via the concentration or dilution of ink. It is said, however, that for normal newspaper printing this is hardly ever necessary.

Inking units with oscillating doctor blades represent the shortest design as far as the roller train is concerned; designs with pick-up roller and scraper blade are the longest, and inking units with an Anilox roller are in the middle. Advantages gained from keyless inking units suggest that keyless inking units will also be used in commercial web offset and sheet-fed offset presses in future. There are also developments aiming at waterless offset printing and the use of emulsion inks that already contain the emulsified dampening solution and thus do not require any additional dampening system.

### Flying Plate Change and Changing the Web Width

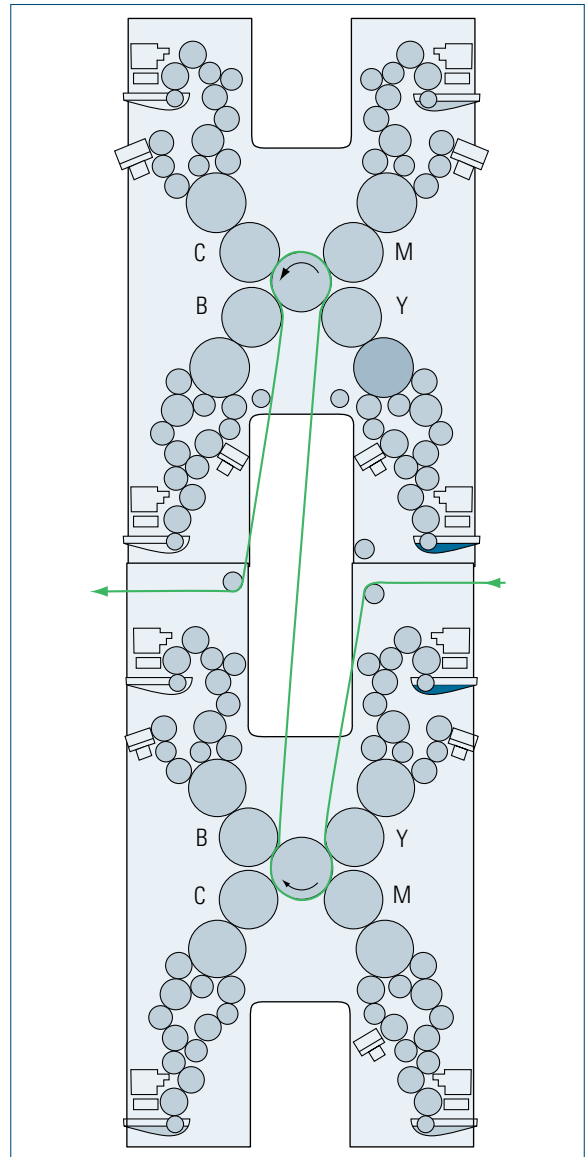
In newspaper printing, several plates are usually mounted on one plate cylinder. This means that these plates can also be exchanged individually (see [figs. 2.1-110 and 8.1-4](#)).



**Fig. 2.1-120**

Four-high unit composed of two stacked H-type printing units (GOSS)

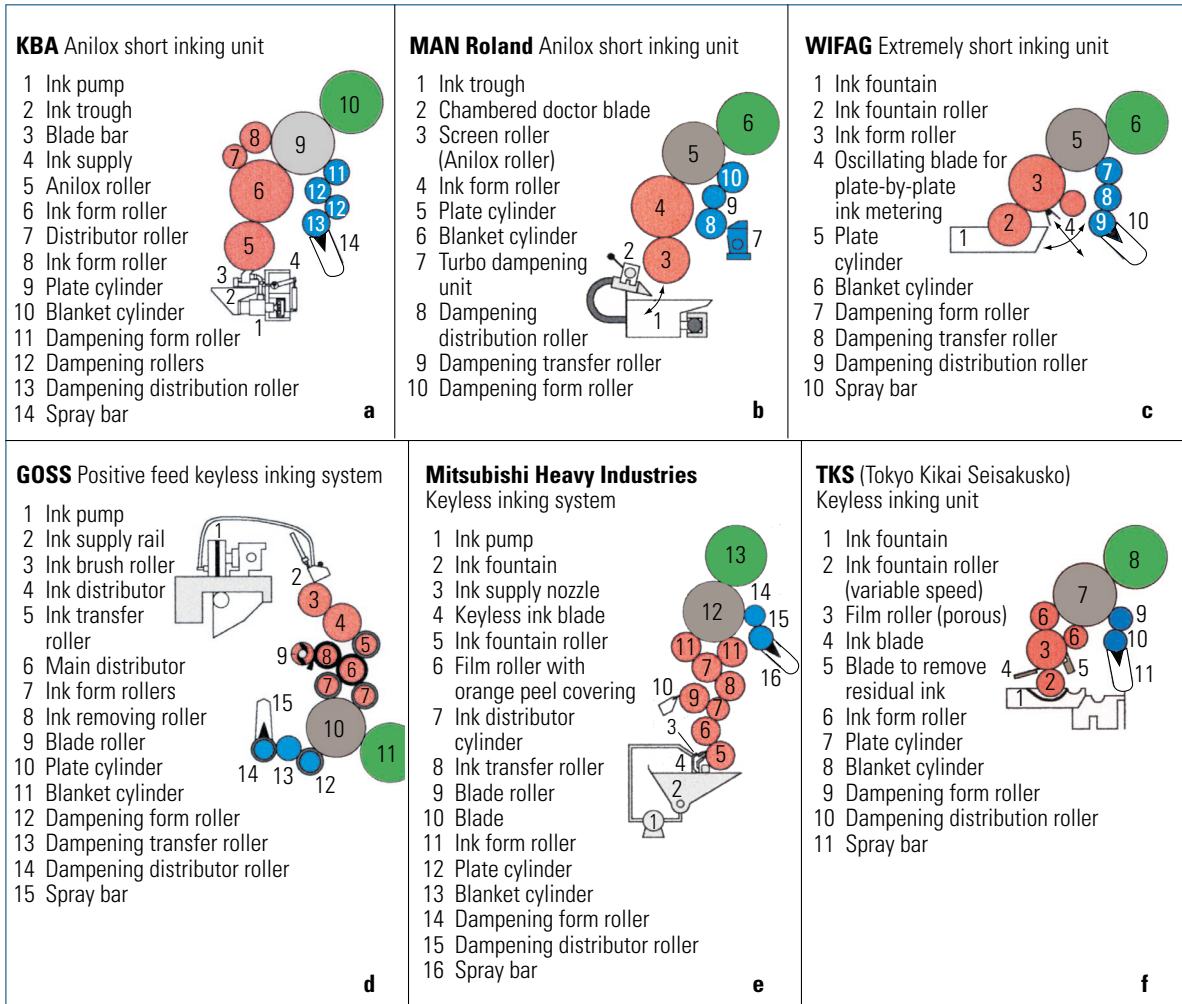
With the transition to shaftless drives on newspaper printing presses, the flying plate change (i.e. while the press is running), as it has been used for years with im-  
printing units on rotogravure and web offset presses, has also become of interest and feasible for newspaper web offset presses, since many different local editions can be printed in one pass uninterrupted by makeready times. This, however, requires double the number of printing units, with half the number being prepared at standstill while the other half is printing. Once the circulation of the local editions is complete, the “flying plate change” takes place and printing continues without interruption. The flying plate change is even used for four-color prints in addition to single-color im-  
prints.



**Fig. 2.1-121**

Twin-satellite configuration for 4/4 prints (MAN Roland)

It is logical to combine a change of the number of pages in the run with this process. To do this, a flying change of web width is required. This is only possible to a limited extent and requires a reduction in production speed while the change operation is in progress. A reel stand with separate reel-arm adjustment is a prerequisite here. In this version, a full-width paper reel



**Fig. 2.1-122** Examples of keyless inking units (KBA)

runs in one half of the reel arm, while a half-width paper reel is mounted in the other half. On the flying splicer, the half-width web is pasted to the full-width web, and the pagination of the product is reduced correspondingly.

### 2.1.4 Remote Control, Measurement and Control Technology/Systems

The running of an offset printing system, whether it be sheet-fed or web-fed printing, involves many adjustments of the various components of the press, especially when *setting the press up* for the job to be printed and

monitoring it during the *print run*. As far as print quality is concerned, this mainly involves setting the different printing units for *ink feed* and *color register*. Then, the dampening units, paper feed, blast and suction air, powder spray device and dryers have to be set to meet the requirements of the job. Machinery also has to be cleaned and washed down from case to case.

If all this work had to be carried out directly on the relevant units of the printing press – that is, on the feeder, printing units, and delivery – it would take a number of operators, or mean moving long distances from control to control, especially with multicolor presses with six to ten printing units, or even web-fed offset

presses with their numerous attachments, such as dryers, folders, and other finishing equipment, which are located relatively far apart. This leads to particularly long setup/makeready times and systems would be slow to respond when any settings had to be changed, leading to high paper waste rates and costs.

Central control consoles, with controls for *setting the main press functions remotely*, have long been standard. With the development of remote control, measurement and control systems, drives, and actuators, settings can be made remotely, not only with the big presses such as those in web offset or newspaper printing, but also in sheet-fed offset presses. Powerful systems have been available since the mid-1970s and these are evolving all the time.

Section 2.1.5 (automation in the print media production) looks at press control consoles and measurement and control systems in detail in connection with special jobs. This is followed by an outline of the individual components of remote control, measurement and control systems, with notes on how they work and the technology used.

### 2.1.4.1 Press Remote Control Systems

#### Press Remote Control Console

Figure 2.1-123 shows the control console of a sheet-fed offset press. One of the sheets that have come off the press in the current run is laid out on the console, with the master proof for that job on a lighting unit. With an illumination system equipped with a special light source meeting standard requirements, the operator can compare the sample taken from the run visually with the master proof. For remote setting of the ink feed on the press, the control console has function keys/push-buttons corresponding to the *ink zones* of the printing unit, which the operator can use to adjust the ink zone openings in the individual printing units and bring the colors into line with the master proof. The control console also has function keys that are used to set the *ink register*, that is, the positions of the individual plate cylinders can be adjusted in circumferential and lateral direction in a series of small steps. There are also displays, showing the current settings of the individual press units. Most control consoles also have facilities for downloading job data (such as color settings) held on storage media.

While control consoles were initially there to set ink feed and register, an increasing number of *other functions* have been added. Figure 2.1-123 also shows a second display area on the control console which is used

to set up other controls, such as dampening unit settings, blowers, and suction controls. It can also be seen that the control console includes a measuring device for *checking color register and match*. Register and color measuring systems are described in more detail later. The *light pen* fitted at the front, which is wired to the control console computer, is another way of setting a color profile via a specially designed *ink zone display*.

Figure 2.1-124 shows a more recent model of a remote control console for sheet-fed presses. Most of the setting controls are no longer present. Individual controls are now set via a graphic user interface and a *touch screen*. What has been retained are the inputs directly related to the printed sheet to adjust the ink supply in the printing units: in the example shown, this is done using a membrane keyboard. The push-buttons in figure 2.1-123 have been replaced by new controls, which are much less susceptible to dirt and knocks.

The control console shown in figure 2.1-124 has had another automation module added in the form of a *measuring device for color measurement* directly on the printed sheet, which it does by scanning with a special optical unit. The measured print image is displayed on the color monitor. (The performance of this color measuring and control technology is described in more detail later on in the next section, see also fig. 2.1-137.)

Figure 2.1-125 shows a remote control console, as shown in figure 2.1-123, installed on a five-color sheet-fed offset press with coating unit and extended delivery. This clearly shows how essential a *central control console* is when it comes to operating a long-line, multi-stage press efficiently, comfortably, and safely for cost-effective production in consistently high quality.

The control console in figure 2.1-125 also has a monitor fitted, as part of a *production management and control system*, providing the press operator with information on forthcoming production schedules, the jobs allocated, and progress on the current job.

#### Ink Feed Preset Systems

Figure 2.1-125 also shows what is known as a *plate image reader*, which is used for color presetting operations. Such devices scan a plate to see how much ink it will require and the data is then input into the press control console for a remote adjustment of ink zone openings, via a cassette tape or other data carrier.

Using this kind of color preset systems greatly reduces makeready (setup) times and wastage rates. By taking the area coverage of the plate and using it to set the *ink zone openings* and *ink strip widths* (as shown



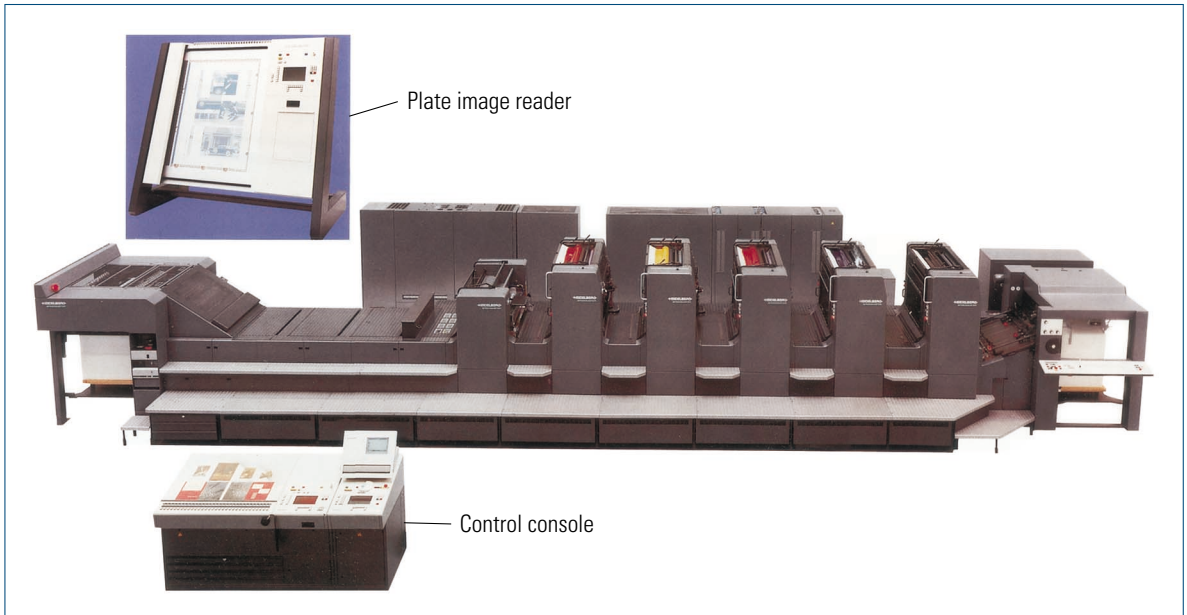
**Fig. 2.1-123**

Remote control console for multicolor sheet-fed offset press with lighting unit for printed sheet inspection and handheld measuring instrument for color register adjustment (CPC1/CPC41 Register mark reader, Heidelberg)

**Fig. 2.1-124**

Remote control console for multicolor sheet-fed offset press with touch screen monitor for remote setting press functions, connected on the left to a color measuring system for color and image control (CP2000/CPC24 ImageControl, Heidelberg)





**Fig. 2.1-125**

Multicolor sheet-fed offset press (with coating unit and extended delivery) and control console for remote press settings and production monitoring, and plate image reader for ink zone presetting (SM 102/CPC 31/DataControl, Heidelberg)

in [fig. 2.1-126b](#)), the inking unit can be brought up to an almost ideal setting for production before a single sheet is fed. With the support offered by measurement and control systems, the ideal setting of the color for each color separation and the final print can be reached with just a few minor adjustments.

[Figure 2.1-126](#) shows how color presetting systems work (see [sec. 2.1.1.3](#), [fig. 2.1-13](#)).

[Figure 2.1-127](#) shows a selection of color presetting systems, which first appeared in printshops around 1982. All these designs rely on optical sensing using a moving scanning bar fitted with a lighting unit, sensors, and filters. There are other designs using CCD cameras, which do not use mechanical moving parts to scan a plate, but these have proved less popular (in particular due to the lighting problems).

### Color Quality

The main factors that govern the quality of the printed image are the *ink supply* to the paper and *the register*, that is, how the individual color separations are printed one on top of the other to give a multicolor image.

In addition to the printer's eye, color measurement and control systems are used that can be utilized not

only to set up a job quickly and keep it adjusted on the run, but also to monitor production itself. Printing *measuring targets/patches in color control strips* for zonal color measurements and individual register marks for color register measurements are now standard. [Figure 2.1-128](#) shows a *color (print) control strip* of this type on a printed sheet taken from the delivery of a sheet-fed press.

The following sections will deal with systems for measuring color and color register. Measuring methods and procedures have already been examined in [section 1.4.4](#); the emphasis now will be on describing complete measuring systems for off-line measurement, that is, off the press, and for in-line measuring, that is, quality measurement and control during the run, using the measuring systems fitted to the machine.

### 2.1.4.2 Color Measurement and Control Systems

There are two basic methods of color measurement: *densitometry* or *colorimetry*. Both systems can be employed in practical use: in handheld equipment for individual readings, or scanning systems for testing a complete sheet automatically. For details of how they work, and how they can be used – the physical princi-

**Fig. 2.1-126** Plate image reader.

**a** Plate image reader for measuring the ink distribution on an offset plate (status: 1982);

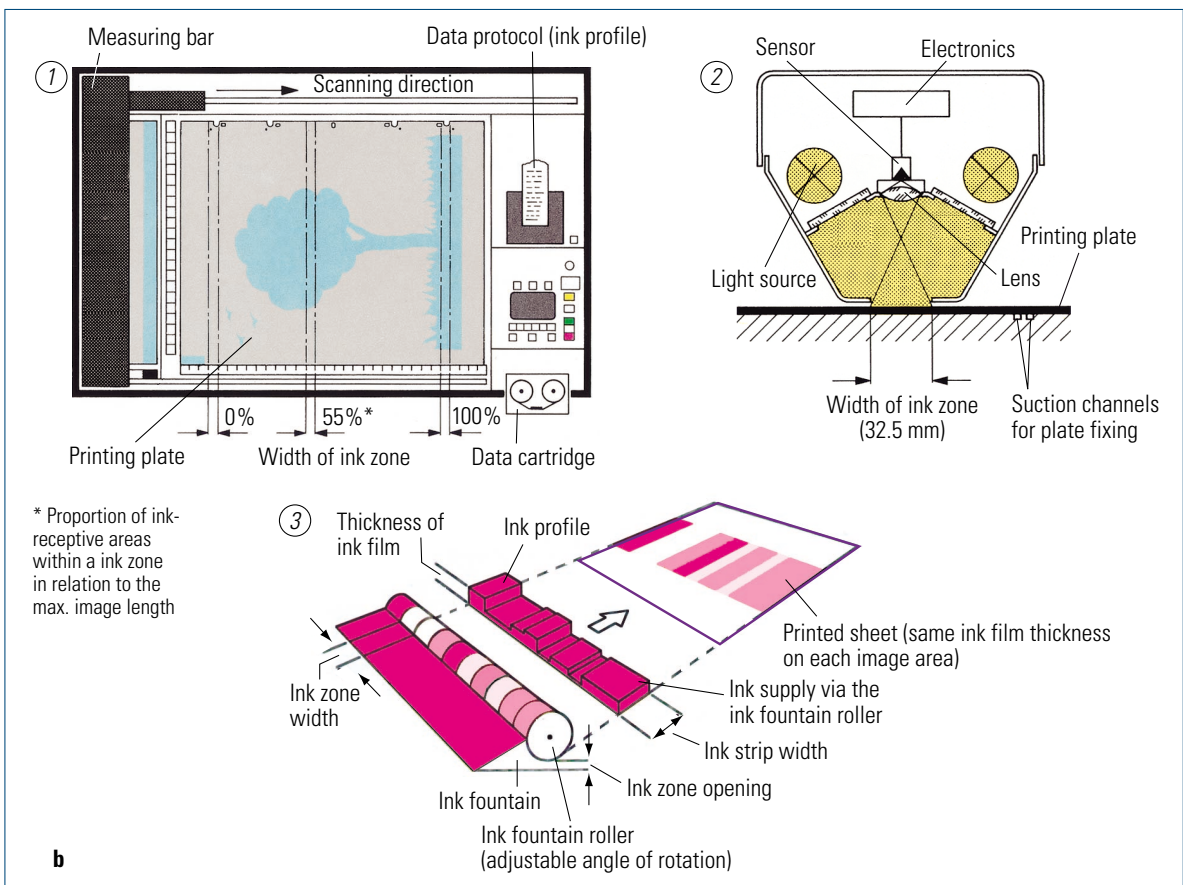
**b** Method for calculating zonal area coverage

1 Zone by zone plate scanning with data output facilities

2 Cross-section of an optical system for measuring zonal area coverage

3 Setting the ink feed on an offset printing unit (ink zone openings and ink strip width) (CPC3, Heidelberg)

Note: CPC31, an advanced model, is shown in Fig. 2.1-125

**a****b**



**Fig. 2.1-127** Plate image reader designs for ink presetting operations.  
**a** DEMIA plate image reader (Device for Measuring an Image Area, Dai Nippon Printing);  
**b** CPC3 plate image reader (Computer Print Control, Heidelberg);  
**c** EPS plate image reader (Electronic Plate Scanner, MAN Roland);  
**d** CPC31 plate image reader (Heidelberg)

ples of densitometry, colorimetric and spectrophotometric measurement systems – see sections 1.4.1, 1.4.2, and 1.4.4. Densitometry measures the optical density of an ink film, which essentially depends on how thick that film is and does not, in principle, measure values. Spectrophotometry and colorimetry make it possible to take readings that correspond to how the human eye sees colors, both qualitatively and quantitatively. It therefore enables much more efficient measurement and control of print quality than densitometry.

### Densitometric Color Measurement

A wide range of *handheld equipment* is available for measuring optical density; one example is shown in figure 2.1-129 (and other examples in sec. 1.4.4). To use handheld densitometers efficiently, special measuring targets/patches must be used in the *color control strips*. In addition to the control strips shown earlier (sec. 1.4.4), figure 2.1-129 shows another variant of powerful control elements, arranged in a control strip (System Brunner). Handheld densitometers are also available which meas-



**Fig. 2.1-128**  
Printed sheet taken from the delivery of a sheet-fed offset press for quality control purposes (Heidelberg)



**Fig. 2.1-129**  
Handheld densitometer for scanning measurement targets in print control strips (R410SB, Techkon/System Brunner)

ure a series of measuring elements (e.g. eight) by scanning a small area with the recording system.

A printed sheet that is 100 cm wide will typically have approximately two hundred test elements arranged

across it. At the least, the solid-tone patches per ink zone and printing unit must be measured, which for four-color printing and thirty-two ink zones gives a total of 128 readings, not to mention the readings for halftone values, ink acceptance, and so on. A typical *measuring patch* is approximately  $5 \times 5 \text{ mm}^2$ , although some systems can use smaller areas (e.g.,  $3 \times 4 \text{ mm}^2$ ).

To increase the level of *automation* and for rapid measurements, there have been measuring systems under development since around 1977 that can measure a number of color control strips *simultaneously* and in later versions by scanning.

Figure 2.1-130 shows one of the earliest systems; simultaneous measurements per ink zone were carried out by a measuring bar (*integrated in the control console*) color by color in specially designed color control strips by moving the bar sideways in several positions.

In the early 1980s, this was followed by systems in which a scanning densitometry sensor head scanned the control strips on a printed sheet automatically in a single pass (figs. 2.1-131, 2.1-132, and 2.1-133; TOBIAS Inc./USA was also a pioneer in the development and use of scanning densitometers).

For a more efficient use of such valuable sensor systems, they have been designed for *multi-machine operation*, such as that shown in figure 2.1-131. Here, a single color measuring system covers printed sheets from a number of presses (practically three or four at most) and sends the data to the relevant control consoles where it appears on the display and the operator can release it to set up the press. The system in figure 2.1-131 can be combined with the control console shown in



**Fig. 2.1-130**  
Densitometer measuring bar for simultaneous color control patches measurements according to ink zones on the printed sheet on the press control console, with color variation displayed zone-wise (CPC I & CPC II, Heidelberg/Gretag)



**Fig. 2.1-131**

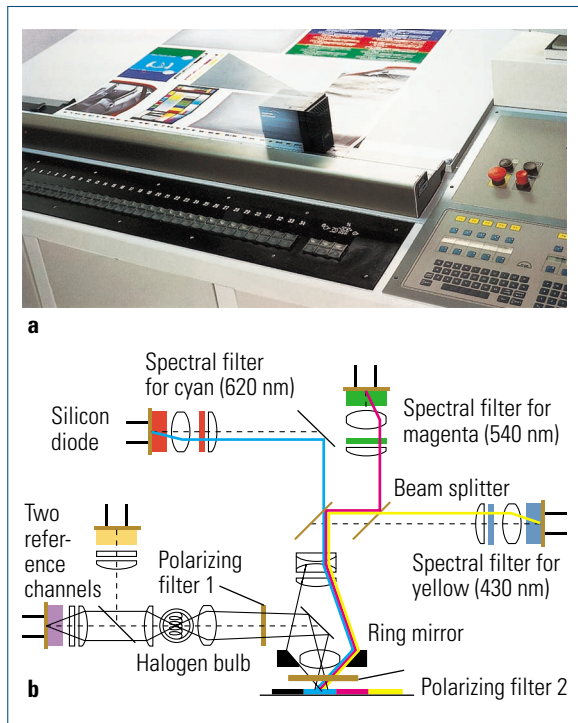
Scanning densitometer for color measurement and data transfer to the press control console for ink control in multi-machine operating mode (CPC 2, Heidelberg)

figure 2.1-123. The development of powerful, practical measuring equipment was accompanied by the development of control algorithms for using the color readings and any variations from measured reference values or setpoints from the proof sheet to calculate adjustments to the ink feed in the printing units and use them to make rapid adjustments during the run.

In contrast to “stand-alone” systems for densitometric color measurements on printed sheets and the ability to cover more than one press at once, there are also systems where densitometric sensors are incorporated in the *press control console* itself. One such measurement and control system is shown in figure 2.1-132a.

As shown in figure 2.1-132b, this system also has optics for simultaneous spectral density measurements. As explained in section 1.4.4, the color filters are not equipped with the usual standard broad-band transmission ranges, but rather with color filters in the path of the beam, which only transmit a narrow wavelength band from the light reflected from the sensor field.

Using specially-designed two-dimensional scanning densitometers, measuring areas in the print image can be selected. This comes in useful for making maximum use of the printed sheet when printing multiple-ups and when continuous control strips (all patches in one row) cannot be used, for instance, in the field of packaging. In this case, staggered control strips are used in the printed



**Fig. 2.1-132**

Scanning densitometer for measuring spectral density.

**a** Scanning densitometer assembled on the press control console;  
**b** Narrow-band densitometric measurements with spectral filters (CCI, MAN Roland/ Grapho Metronic)



**Fig. 2.1-133**

Scanning densitometer for two-dimensional measurement positions on the printed sheet (Densitronic, KBA)

image. In a system like the one shown in [figure 2.1-133](#), the densitometer head is moved in the x and y axes to bring it into position at the preprogrammed coordinates.

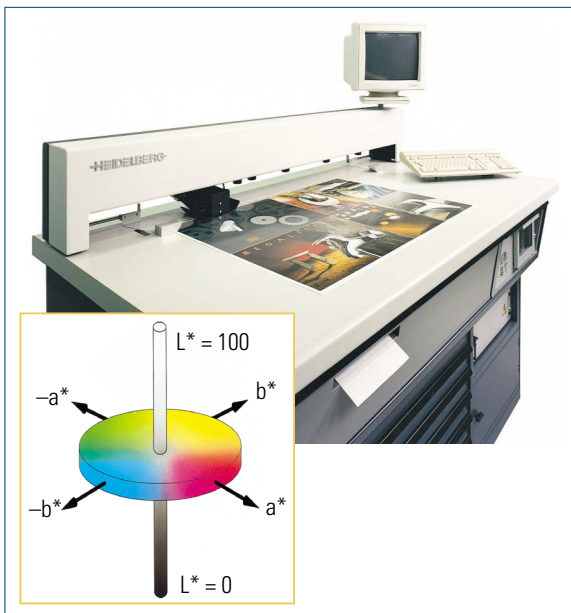
### Spectral Color Measurement

By the late 1980s, the performance and quality of color measuring equipment and its use in the pressroom experienced a breakthrough by providing innovative opto-electronic equipment, and powerful computing systems, and by making components cheaper. Color measurement could be taken out of the lab and put to practical use.

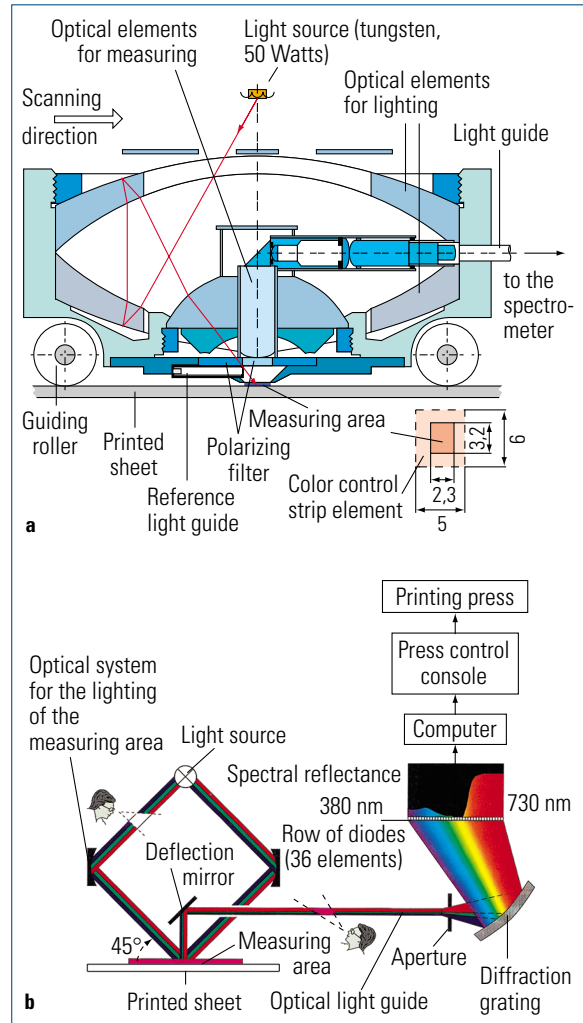
[Figure 2.1-134](#) shows a system with a *scanning spectrometer sensor head*. Such measuring systems can record the three coordinates for precisely specifying color in a color space (e.g.,  $L^*a^*b^*$  color space).

The components of the system in [figure 2.1-134](#) and how they work are shown schematically in [figure 2.1-135](#). The measuring patch is illuminated by an annular optic and the reflected light is passed to a fixed spectrometer in the unit via light guides/fiber optics as the measuring lens is moved.

This spectrometer uses the light diffraction from a holographic diffraction grating, which passes the light received from the measuring patch to a



**Fig. 2.1-134** Spectrophotometer (scanning spectrophotometer) for color measurement and control (CPC2-S, Heidelberg)



**Fig. 2.1-135**

How the scanning spectrometer in [figure 2.1-134](#) works.

**a** The optical measuring system;

**b** Beam path for measuring the reflected spectrum and components for processing signals

row of diodes where the light is analyzed in the visible wavelength range in a narrow band process. The reflected spectrum from the ink is thus recorded as a kind of “fingerprint” of 36 measured values at wavelength intervals of 10 nm. The color values are then computed from the reflectance spectrum. Any color deviations in the print can be assessed as the human eye would see them.

To control the inking on the press itself, the colorimetric values have to be converted to settings for the

inking units for the four process colors (cyan, magenta, yellow, and black). This meant creating *specific algorithms*, using empirical parameters to some extent due to the complexity of the numerous processes involved in measurement and printing and since results vary from one print stock to another. Adaptive, self-learning systems can improve the continuous conversion of readings to settings on the press as the readings themselves vary. Figure 2.1-136 shows how the inking on the press is controlled in simplified diagrammatic form.

Typically, spectral color measurement and control enables the color to be brought up to specification within three or four adjustment steps, whereas densitometric measuring techniques can take up to eight or ten adjustments, depending on how complex the job is and what the print stock is being used.

In the diagram showing how color values are converted to press settings in figure 2.1-136 an intermediate value is used, namely the *optical color density*: this enables the control algorithm in the press control console, which was originally designed for color density readings, to continue to be used. In this way both density and colorimetric readings can be used for control purposes.

A wide range of *handheld spectral color measuring devices* is also available and has, in fact, become virtually

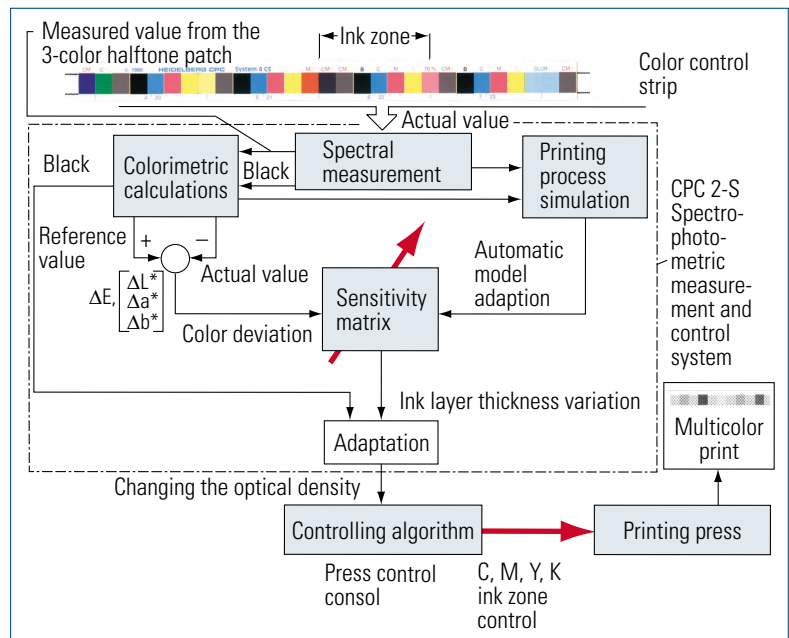
standard since around 1995. Nearly all such models include a facility for separately calculating and displaying optical density values from spectrum readings (spectrophotometer). This can also be done with colorimetric, tristimulus filter-based measurement instruments.

### Image Measurement

Both optical density measurement and spectrophotometry are based on measuring patches (color control strips) that are printed together with the image. Knowing the area coverage of the individual color separations and using colorimetric measuring techniques it is, in principle, possible to use the printed image itself to control the press settings during *setup/makeready* and during *production*. However, the data from the prepress is needed for this, especially on the coverage of the individual colors. During the production itself, specially selected sections of the print image can be used (such as solid-tone patches of individual colors). As mentioned before for densitometric measuring systems, there are X/Y coordinate systems where the sensor head moves in two dimensions to specified coordinates in the test area. This is essential where the color control strips are staggered, that is, distributed over the image area, but they are also capable of recording and analyzing positions in the print image itself.

**Fig. 2.1-136**

Block diagram for converting the color variation  $\Delta E$  to control variables for adjusting the ink supply on the press (Heidelberg)





The spectrophotometric measuring unit shown in [figure 2.1-137](#) can cover the entire image area, scanning it at a resolution of approximately  $2 \times 2.5 \text{ mm}^2$ . This system can be used for analyzing a series of consecutive control strips or test points distributed over the image area. Alternatively, predefined points in the image area can be selected and used for *measurement and control* purposes. One of the major advantages of such a system, which can scan the whole image area, is that as well as checking the print color it can also be used to *inspect the printed image* overall, i. e. for scratches or blemishes, using suitable image processing algorithms. This system can therefore be used both for conventional densitometry, spectrophotometry on print control elements and for checking the image itself.

### Man-Machine Control Systems

With these densitometry and colorimetric systems, it is possible to control what happens on the press. Since, however, checking the printed sheets on the run involves the operator taking a sheet from the delivery as in [figure 2.1-128](#), so that the checking takes place off the press, a closed *loop control circuit* in the strict sense of the term is not realized. The press operator determines the intervals at which checks are made and it is he who starts the checking process. The computer in the meas-

urement and control system determines the deviations between the measured values and the setpoint values and calculates the adjustments that need to be made to the ink supply for the individual inks accordingly. Generally speaking, the density and/or color value readings and any adjustments required are first shown on the measurement and control system screen. The operator is then free to make adjustments/corrections based on his experience and to decide at the push of a button about releasing the values to the press for adjusting the printing units. In other words, it is the operator who completes/closes the feedback loop. In system terms, this is a “*sample-and-hold control*” with operator-controlled measurement and control cycles. Comparing the readings with the reference settings, and allowing for permitted tolerances, the press operator monitors the colors converging towards the setpoint and decides himself when to remove another sample sheet and whether those readings justify adjusting the press. The man-machine interaction governs the quality, and hence the cost effectiveness, of the printing process.

#### 2.1.4.3 Register Measurement and Control

At the same time as measuring and controlling the ink supply/the color, the color register is measured and controlled: that is, the color separations are put into register in the individual printing units.

Once again, systems with different levels of automation are available. As detailed in [section 2.1.5](#), this may be anything from simple visual aids (*optical magnifying glasses*) to handheld instruments that check the register reliably, quickly, and accurately from register marks aided by opto-electric components.

[Figure 2.1-138](#) shows a *register measurement and control device*, which is also shown installed in the control console in [figure 2.1-123](#), in more detail in terms of its constituent components and how it works.

The cutaway view ([fig. 2.1-138b](#)) shows how the unit uses two high-resolution CCD line sensors (accurate to approximately  $5 \mu\text{m}$ ) to measure the distance between lines and register marks: one CCD line sensors for the register lines for measuring the circumferential register, and one CCD sensor for the register lines in print direction to check the lateral register.

This measuring system is designed so that any variations in the register marks regarding reference values are passed to the computer in the control console via infrared light, from where the plate cylinders are adjusted.

Another register measurement system is shown in [figure 2.1-139](#). The *video magnifying glass* can be used to



**Fig. 2.1-137**

Spectrophotometric measuring system for color measurement and control and for print image inspection and analysis (CPC 24/ImageControl, Heidelberg)

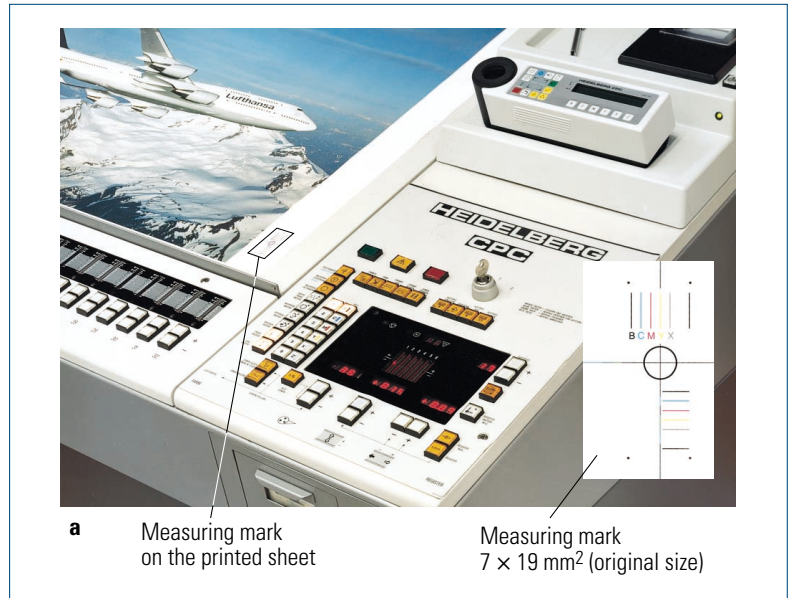
**Fig. 2.1-138**

Handheld instrument (register mark reader) for color register measurements of printed measuring marks.

**a** Register mark reader on the control console of a sheet-fed press and measuring marks;

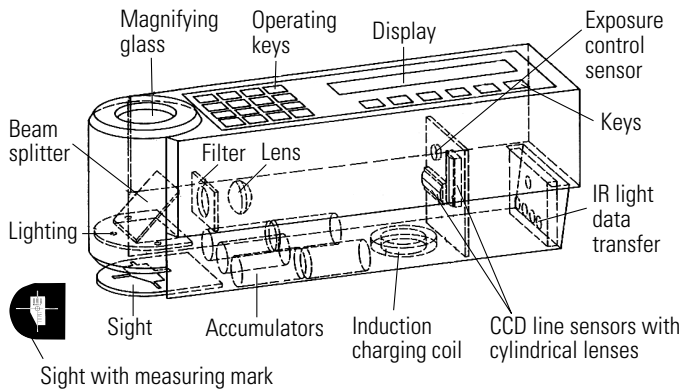
**b** Electronic/optical components of the measuring instrument and a measuring mark "in the sight";

**c** Transmitting data to the press control console computer by infrared signals (CPC41 Register mark reader, Heidelberg)

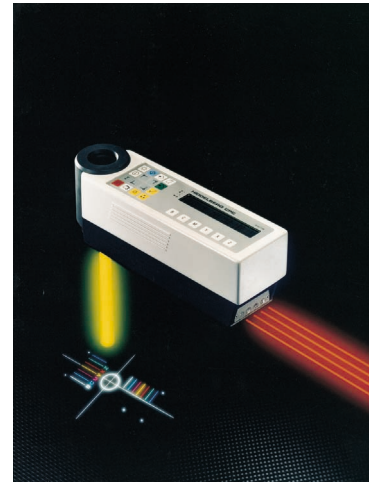


**a** Measuring mark on the printed sheet

Measuring mark  $7 \times 19 \text{ mm}^2$  (original size)



**b**



**c**

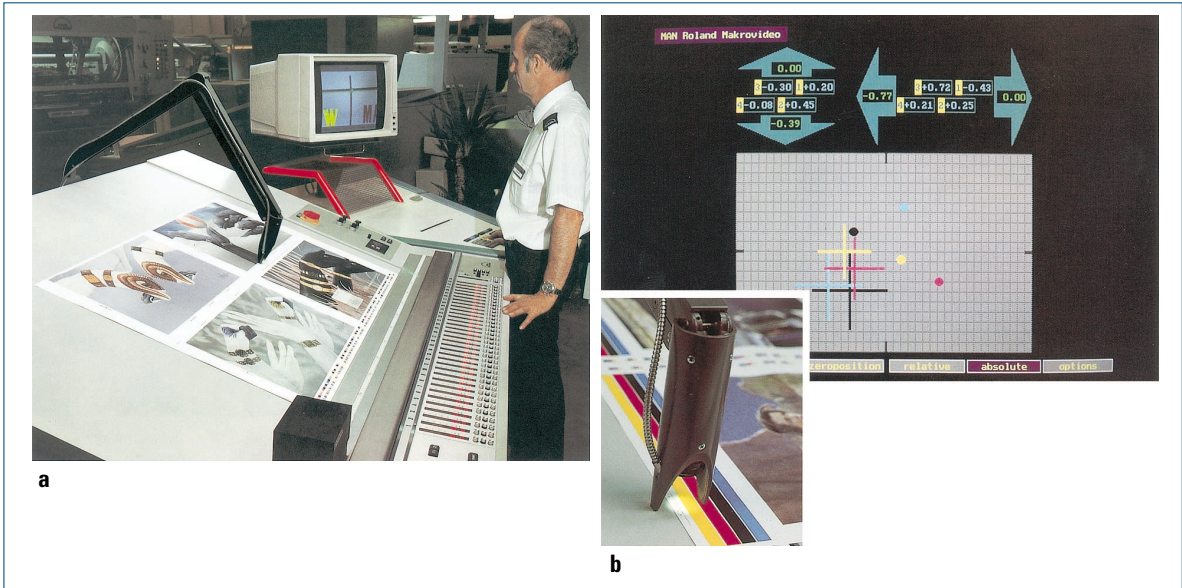
display register marks in the image area on the monitor. By checking the register marks by computer and using appropriate image processing algorithms, any register adjustments required can be detected and quantified. The operator then adjusts the press accordingly.

Thanks to today's register systems used in the platemaking process, plates can be mounted with such a high degree of register accuracy that only minor corrections in accordance with the image are still necessary. These can then be carried out quickly and easily

by the operator. Setting the ink supply correctly is the greatest challenge and also where the greatest potential for reducing makeready times lies. The register is generally set up at the same time as the ink supply; in fact, the correct color register is reached more quickly than the correct ink supply.

#### 2.1.4.4 Inspection of the Printed Image

The ink supply and color register are not the only factors affecting print quality. The images themselves may



**Fig. 2.1-139** “Video magnifying glass” for color register measurement and control.

- a** Video magnifying glass with color monitor on the control console of a sheet-fed offset press;  
**b** Video magnifying glass with lighting unit and display of the register mark positions on the monitor (CCI, MAN Roland)

be particularly delicate, or the client may want particular details brought out. There could also be printing problems arising from problems with the paper feed or the print run itself which may not show up on any measuring elements. These may include such things as scratches because the paper is not feeding correctly or “hickeys” due to spots on the blanket.

To check the print quality, especially on fast moving webs in web presses, *visual inspection tools* are used that enable the operator to detect such faults quickly, or that warn him to take corrective action. Such monitoring systems rely mainly on sophisticated high-grade camera equipment.

By way of example, [figure 2.1-140](#) shows an image captured and displayed on a color monitor. Any deviations in image quality, and in measuring marks in particular, show up quickly. With properly calibrated color monitors, *color deviation* between ok image (reference image) and printed image can be detected. But this depends largely on the skill of the operator since measuring color variations via video camera systems is a relatively inexact science.

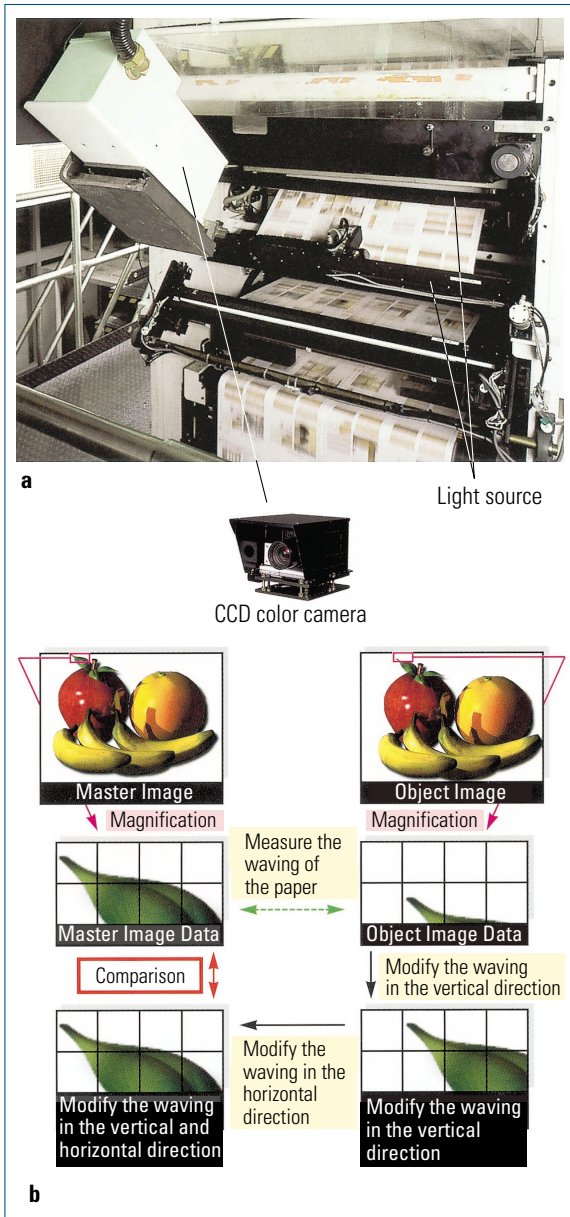
[Figure 2.1-141](#) shows a number of other examples of image inspection. *Splitting the display into two parts* to

visually compare the reference image and current print image has proved useful. The system’s high-resolution camera also spots small *measuring marks*, whose position indicates *color register problems* that can be passed on directly to adjust the plate cylinder settings.

Such high-resolution camera-based print monitoring systems generally look at just small sections of the print image, yet can monitor the *entire print image* if powerful and sophisticated enough. Depending on the computing power and memory available, these systems can be used to monitor the print run at high speeds in *real time*, process data immediately and pass warnings on to the operator as necessary. This enables the operator to monitor the status of the print run or analyze the quality from a single copy in detail. The printed image can be displayed on screen at specified intervals while, within the press itself, data can be read and analyzed in real time.

Such camera-based web monitoring systems are mainly used with *web-fed offset presses*; but there are also systems that can record and analyze part or all of the print image in sheet-fed offset machines.

[Figure 2.1-142a](#) shows a camera system fitted to the delivery of a sheet-fed offset press. The cameras are in-



**Fig. 2.1-140** Image inspection system on a web offset press.  
**a** CCD line color camera and illumination in the superstructure of a web offset press;  
**b** Example of image inspection and web positioning/web guiding system without special measuring marks (DOPRIME, Dai Nippon Printing)

tegrated into the delivery and record the evenly conveyed sheet.

Using two CCD cameras, the system shown in [figure 2.1-142b](#) scans multicolored printed sheets on a line by line basis where readings are taken on the impression cylinder of the coating unit or last printing unit.

Such systems are technologically complex and do not yet meet the measuring quality required for automated color and register control purposes. Systems still have to be developed specifically for this purpose.

[Figure 2.1-143](#) shows the basic outline of an in-line print control system for a sheet-fed offset press. There are a number of technological challenges here. The control system has to be capable of resolving the geometry and colors of the print image, work fast enough to record and process data on the run, and position the printed sheet for measurement purposes on the cylinder. The measuring optics cannot generally handle major positional variations so that, as [figure 2.1-143b](#) shows, blowers have to be used to blow the sheet onto the impression cylinder to ensure that the rear edge of the printed sheet is always at the same position on the cylinder when it leaves the nip between the blanket and impression cylinder.

The actual print image is compared with the reference image using *image processing tools*. If it is out of true, there are a number of options available. The image can be displayed on screen, *marking the area* where it has been seen to be out of register, and the operator can then intervene ([fig. 2.1-143c](#)). Any print defects can be easily tagged by initiating an *alarm* and/or inserting a *marker strip* (tape inserter) in the delivery pile, as in [figure 2.1-143b](#) (the pile must then be sorted manually). The system in [figure 2.1-142b](#) has a double delivery with a *waste diverter*, which can be used to sort out any misprinted sheets automatically. [Figure 2.1-143c](#) shows a number of examples of detected quality flaws, such as splashes of oil on the blanket resulting in smudges on the print, colors out of register that show up in close register areas, and color defects, which show up as gray scale variations on the camera color channels. The operator can spot these but the monitor display, with alarms if fitted, will guide him to make the necessary visual inspection. This design dates back to around 1987.

The possibilities offered by opto-electronics, powerful color camera systems, and image processing algorithms have resulted in a wide range of specialized systems. Special applications have been developed for different printing methods and production systems,

**Fig. 2.1-141**

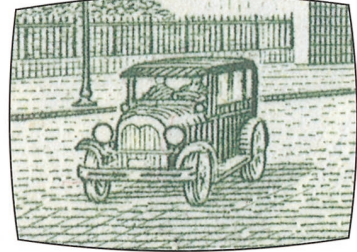
Print image inspection examples (recorded with CCD array color camera).

- a** Details of monochrome print image;
- b** Visual comparison of the coloring on the color monitor with a multicolor print (split screen image);
- c** Spots (hickeys) in the print image;
- d** Color register marks in the print image (monitor display);
- e** Camera and illumination system (Image Inspector, Baldwin)

zoomed out image



zoomed in image



**a**

split screen image



split screen image



**b**

**e**

camera and strobe

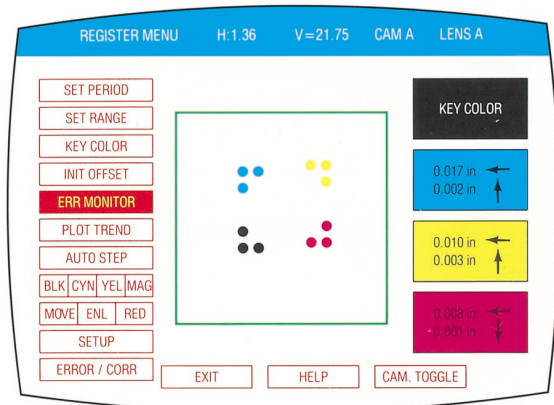


spots (hickeys)



**c**

open loop register error display

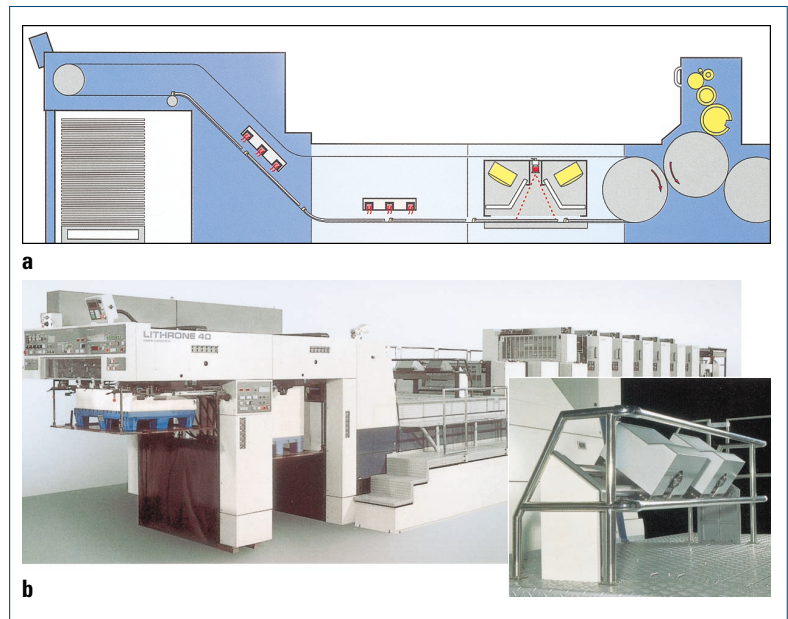


**d**

**Fig. 2.1-142**

In-line print quality inspection in sheet-fed offset presses.

- a** Inspection of a printed sheet using color camera system in the extended delivery (Qualitronic/Rapida 104, Eltromat/KBA);  
**b** Print quality assessment system for inspecting printed sheets on the impression cylinder of the coating unit, using two color camera systems (PQA/Lithrone 40, Komori)



especially for web offset and the production of special printing products, such as labels (see [sec. 2.5.3](#), e. g., [fig. 2.5-23](#)) and security printing. The most commonly used applications are those for web monitoring in web offset and rotogravure; yet there are also models for special “stand-alone” print quality measuring and checking equipment.

[Figure 2.1-144](#) shows an example of such a *print quality/image inspection system* that can be used to check multicolor sheets across the entire sheet once they have been printed. Any sheets that fail to pass inspection can be diverted via a waste diverter.

There are not as yet any image inspection systems that can measure and control color in-line with the necessary precision while at the same time being financially viable. All the leading press manufacturers and suppliers are, however, working on them.

The next section looks at special systems for in-line print quality measurement and control.

### 2.1.4.5 In-line Print Quality Measurement and Control Systems

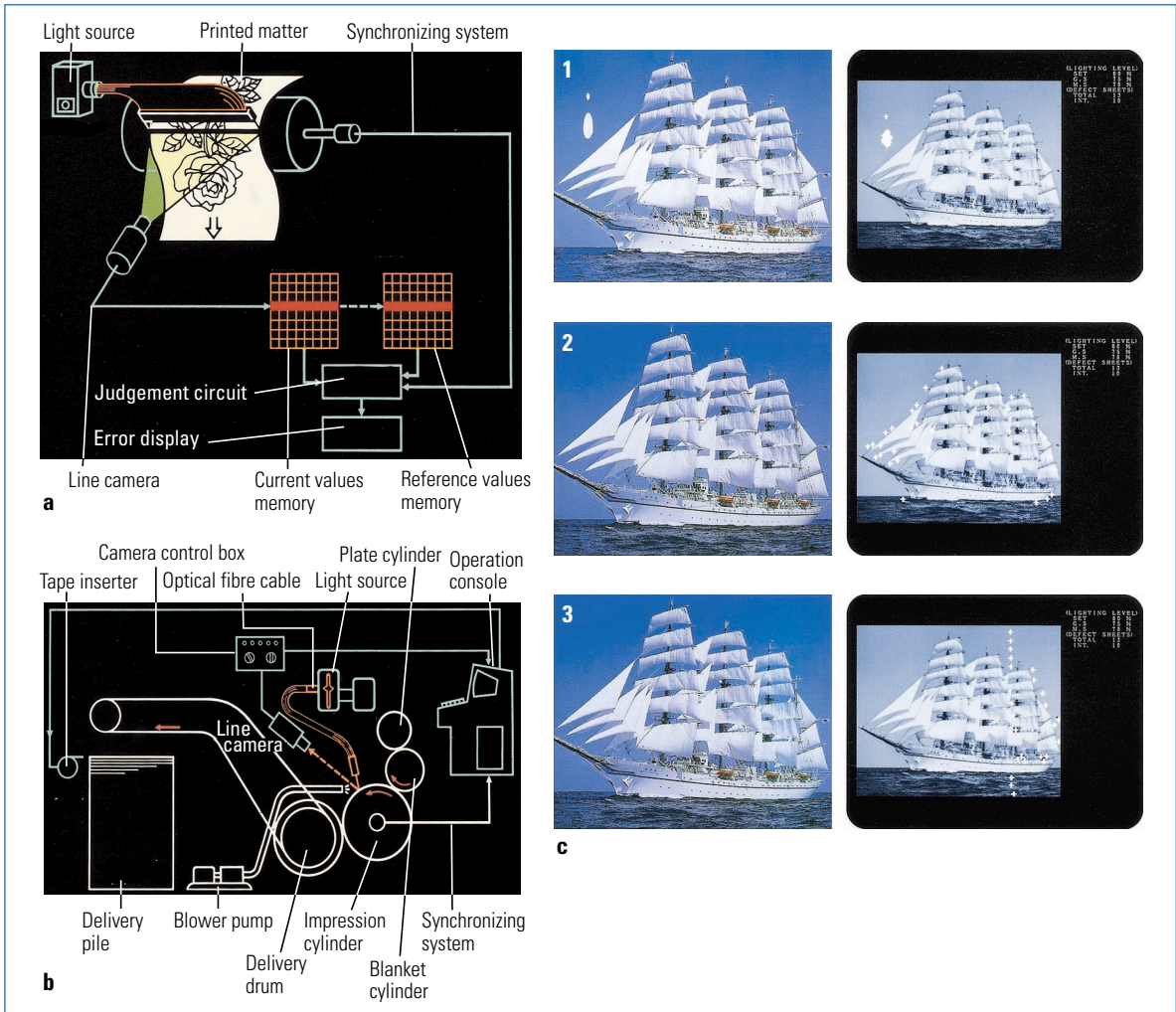
#### In-line Color Measurement Systems

[Figure 2.1-145a](#) shows one of the first installations (around 1985) of an *in-line color measuring system* for sheet-fed offset presses.

This system uses a densitometer measuring head/bar to read the color control strips on the impression cylinder of the last printing unit. The readings are displayed on a monitor fitted to the press control console. The operator calculates the ink settings required from the density readings, and sets the individual inking units by remote control from the press control.

If such control systems are not very widespread as yet, this is probably because they are very expensive and not very cost-effective. More importantly because they are not very powerful when it comes to *setting up* print jobs. It is easier to use systems for monitoring on the *run*, which do not require high-precision absolute readings, but merely indicate if the print settings/reference values are off. With current offset presses, on the other hand, there is no need to monitor the ink feed continuously on the run. Once set up, presses print in a very stable condition, so the off-line print quality measurement for the setup/makeready phase and checks on the run usually suffice.

From an economic standpoint, *in-line color measurement systems* are generally more suitable for web printing than sheet-fed printing presses. This is, on the one hand, based on the comparison of the additional costs that arise from an in-line measurement system with the high base costs of the production system for web printing systems and on the other hand also due



**Fig. 2.1-143** Print quality control system for sheet-fed offset presses.

**a** Measured-value recording and image processing;

**b** Arrangement of system components in the printing unit of a sheet-fed offset press, with device (tape inserter) for marking faulty sheets in the delivery stack;

**c** Typical print image defects and corresponding displays on the color monitor

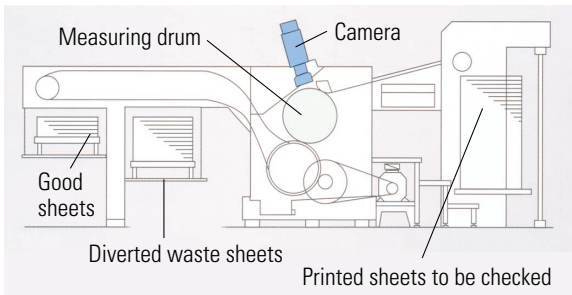
1 Spots, due to inking problems, for instance oil drops on blanket

2 Colors out of register, visible in fine structures of the image

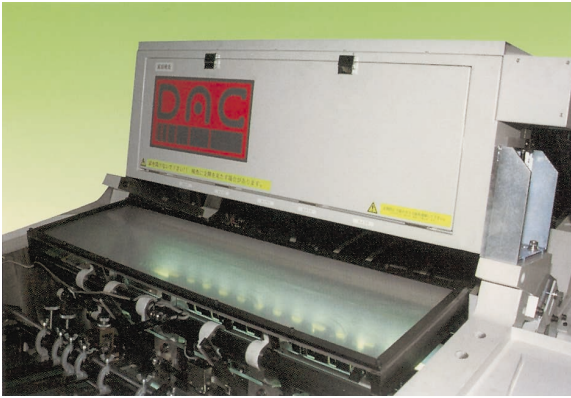
3 Serious color variations detected by changes in gray scale readings of the camera system (Mitsubishi)

to the advantages of *constant quality monitoring* at extremely high production speeds. Technical concepts for in-line color density measurement are based on *color control strips* that are printed together with the image, whereby the measurement takes place either via a measuring head mounted at right angles to the di-

rection of web travel or a measurement system that simultaneously records all measured values across the width of the web. There are examples of both of these concepts installed, although *scanning systems* are more common, primarily due to the significantly lower technical expenditure. A *web-wide measurement sys-*



a



b

**Fig. 2.1-144**

Measuring equipment for the inspection of printed sheets.

**a** Diagram of the "measuring machine" for printed sheet inspections;

**b** Color camera system for inspection of the entire sheet (Symphony Color SLC/SKS, DAC Engineering/Hirose)

tem has the advantage in web offset printing of recording the zonal measurement values for color control quickly at the makeready stage and above all from the same web section. For *production*, on the other hand, the successive recording of measured values with a scanning system that only releases all the zonal measurement values after measuring several web sections/signatures is sufficient due to the stability of the ink feed in production.

Figure 2.1-145b shows an example of a measuring unit that determines color values on color control strips by a *measuring head*, which moves at right angles to the direction of web travel. It should be emphasized that the measurement systems can be designed in such a way that only narrow measurement

sections in the direction of print are needed (e.g., 2 mm at a width of approximately 5 mm) and therefore hardly any detrimental paper cutting is needed or that these narrow color control strips can be incorporated in the gutter or trim edges of the end product.

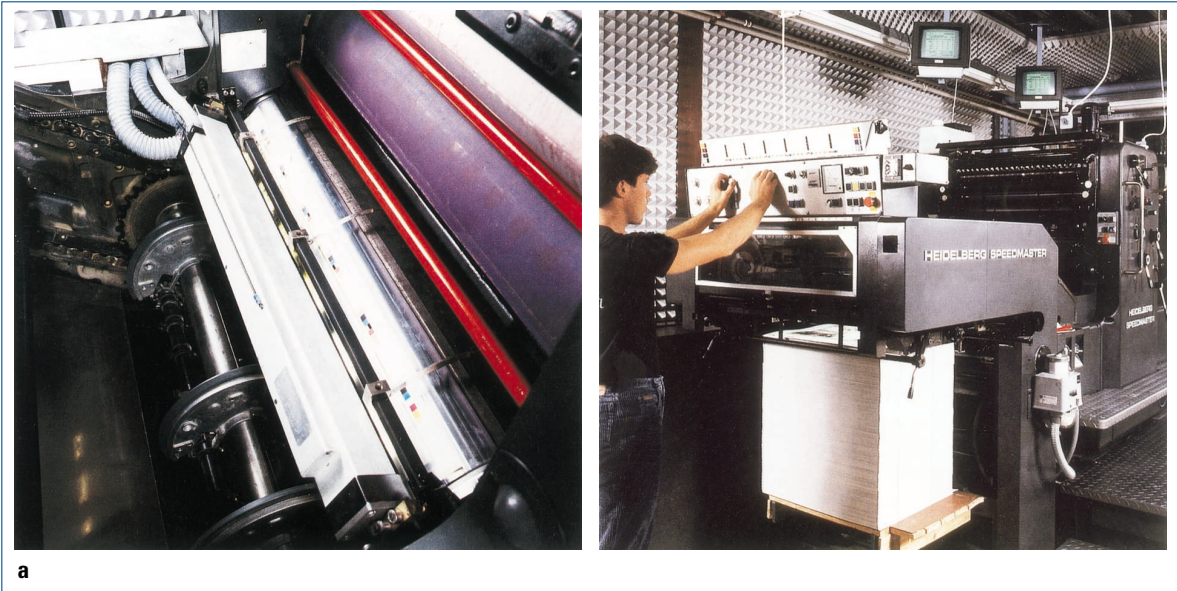
Once in-line color measurement and control systems become available that can successfully handle a number of tasks at once, such as *color control, register, and image inspection*, they could really make a breakthrough into the market. When it comes to *certifying* businesses to ISO 9000, which imposes high quality requirements for printed products such as are required in the packaging industry, using such measurement systems becomes interesting. The challenges to designers and manufacturers are mainly in terms of optimum system configuration, designs and cost structures to give a viable return on investment.

Figure 2.1-146 shows a design for a *multi-functional in-line print quality measuring system*, using advanced technology to capture the entire print image in fine resolution (approximately  $1 \times 1 \text{ mm}^2$ ), plus a colorimetric system for color-measurement and controlling the inking units. Sophisticated fiber optic systems, especially designed CCD area arrays for measuring color across the whole format simultaneously with four channels to carry out colorimetric and black measurements, and high-precision optical modules were required.

Figure 2.1-147b shows a color monitor on the control console of a sheet-fed offset press, showing a printed sheet display supplied by the measuring system as shown in figure 2.1-146. Figure 2.1-147a shows how the signals are passed from the measuring bar via fiber optics to the CCD array in the receiver unit. This system not only monitors printing on the run in real-time, that is, on a sheet by sheet basis, but can also be used for makeready purposes, and in particular obviates the need for color control strips. With this system, the digital data for the individual color separations is provided from prepress, or else a copy is measured to serve as a reference sheet.

This system is not widespread at present, despite successful test installations and field trials and this can mainly be attributed to the costs involved. These kinds of systems are, however, set to become more popular as high-tech components in printing become more cost-effective. Systems like this will be another major step towards ensuring output, increasing productivity and making life easier for the operator.

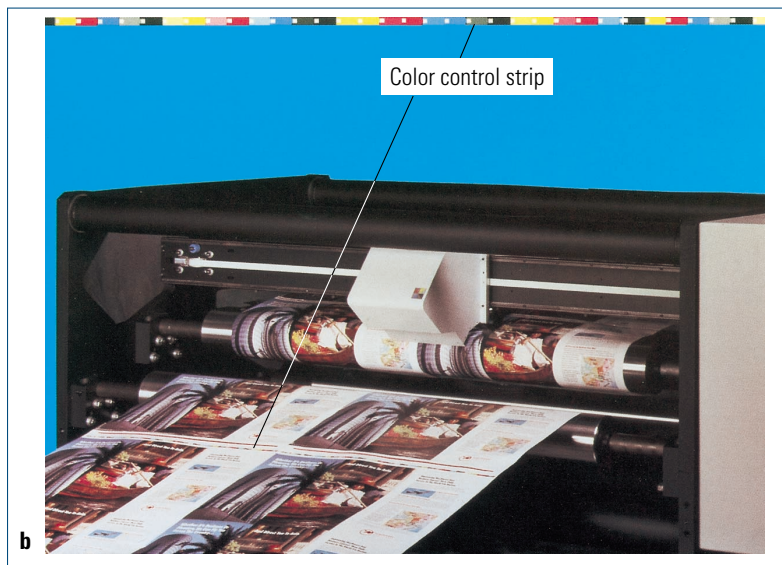


**Fig. 2.1-145**

In-line color density measuring systems.

**a** In-line color densitometer for use with print control strips on the impression cylinder of the last printing unit in a sheet-fed offset press (Reprotest);

**b** Scanning system for in-line color measurement (optical densities, colorimetric values) on web offset printing presses (ColorQuick, Graphic Microsystems)



### In-line Color Register Measurement System

As illustrated in the previous sections, in-line color register monitoring is feasible with *web-fed presses*, given the existing measurement systems available.

Particularly in terms of investment, the use of advanced measurement and control systems as required for register control at high speeds (up to 15 m/s) can be extended to the entire production system as a whole. Such systems are particularly necessary in web-

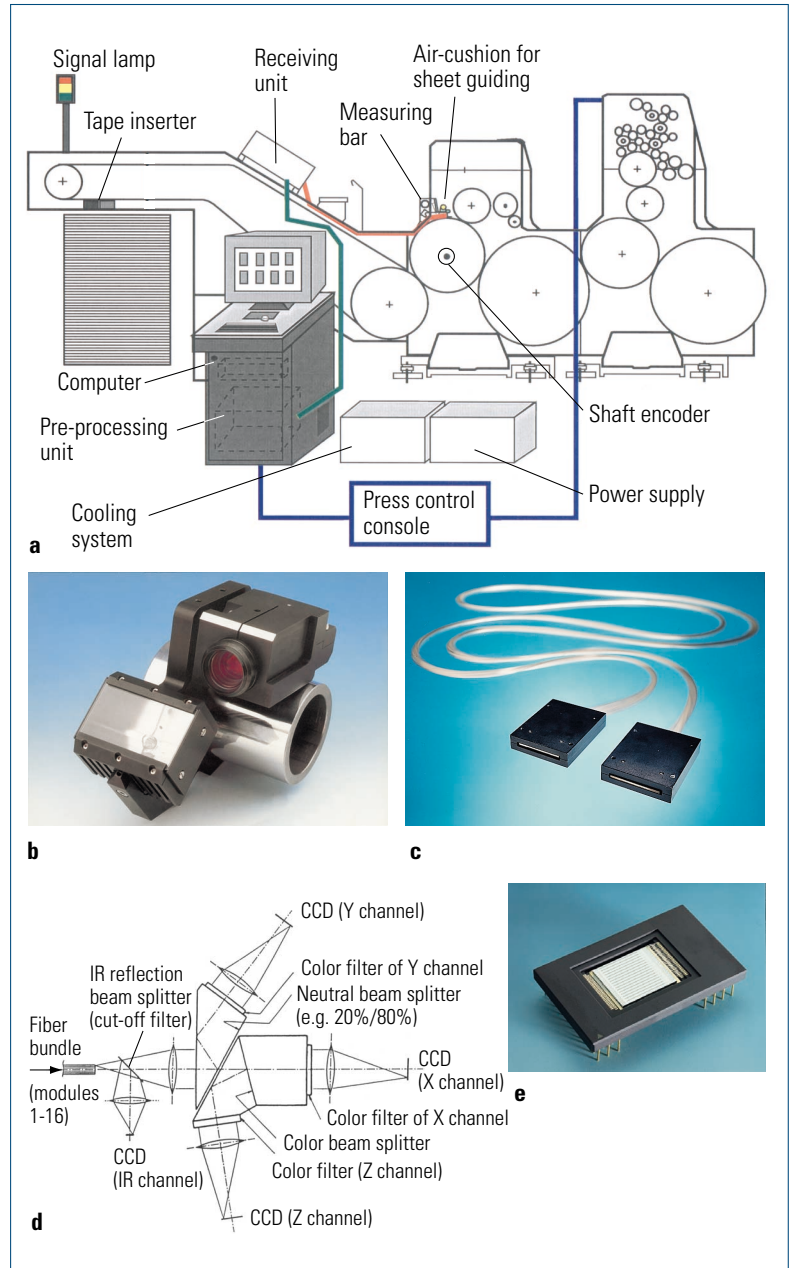
fed presses, with their high output and correspondingly high scrap rate if problems occur, not to mention the fact that with production systems that work on a reel to reel basis it is impossible to divert individual sheets for checking off-line.

Figure 2.1-148 shows a measuring system especially designed for register control. A measuring head at right angles to the print stream monitors small register marks in the gutter or trim edges, or those that can

**Fig. 2.1-146**

In-line color measurement and control, and image inspection system.

- a** System components and their locations in a sheet-fed offset press;  
**b** Sensor module used as part of the measuring bar (16 modules across the full width of the sheet, module width 65 mm) with illumination and optical sensors;  
**c** Fiber optic module for transmitting measuring signals (module width 65 mm) to the receiver unit;  
**d** Beam splitter for splitting the recorded light into the three color channels for colorimetric measurement (with tristimulus filters) and in IR channel for measuring black;  
**e** CCD receiver array for measuring color signals from the measuring bar (16 modules for 32 ink zones) for one color channel (CPC 23, Heidelberg).



be “hidden” in the print image itself. Similar systems are so sensitive that they can reliably sense measuring targets of less than 1 mm in diameter and use them for control purposes (the smallest targets at present are approximately in the range of 0.2 to 0.3 mm in diameter).

In-line color register systems have also established themselves in practice and proven themselves cost-effective in *sheet-fed offset*.

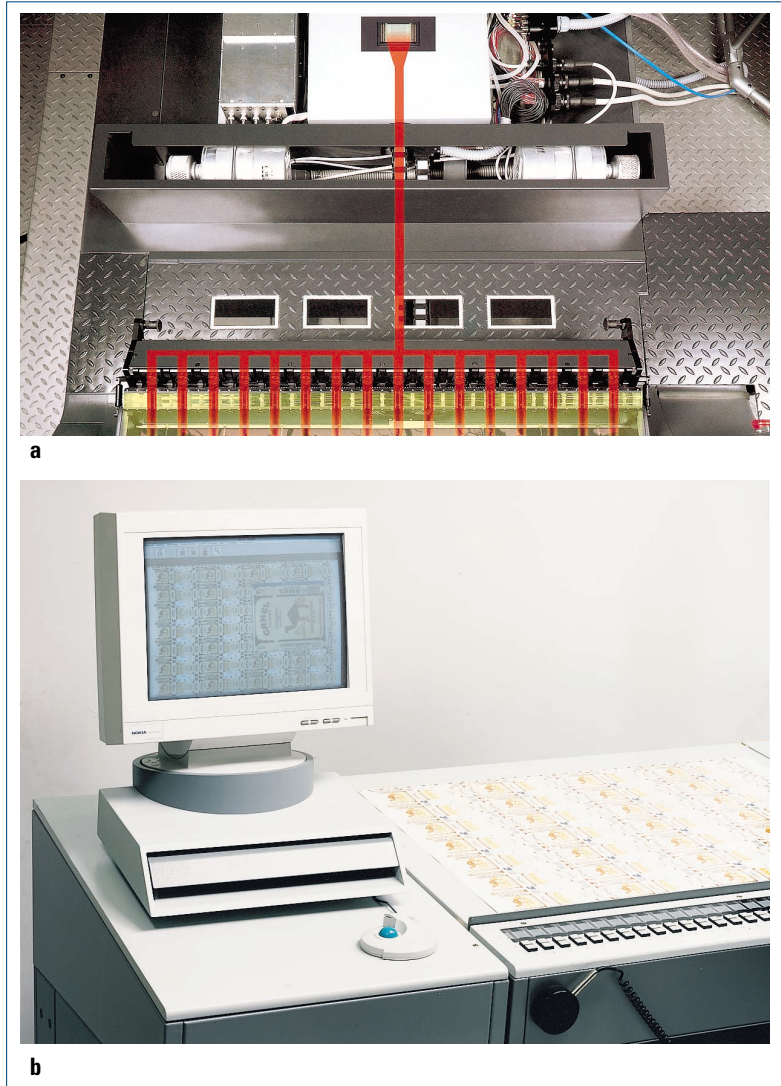
One such control system is shown in [figure 2.1-149](#), where two register sensors on either side margin of the printed sheet monitor register marks with the press run-

**Fig. 2.1-147**

In-line image inspection (with measuring system, shown in [fig. 2.1-146](#)).

**a** Transmitting optical signals from the measuring bar (16 sensor modules) on the impression cylinder via fiber optics (and beam splitter) to the CCD array in the receiver unit;

**b** Printed image (with zoomed-in detail) displayed on the color monitor of a press control console (CPC 23, Heidelberg).



ning at full speed. The sensors are fitted near the impression cylinder on the last printing unit as shown in [figure 2.1-149b](#). The readings can be used directly to make the necessary circumferential, lateral, and diagonal (cocking) registers adjustments. The register marks are shown in [figure 2.1-149a](#). Each mark is approximately 1 mm × 1.5 mm.

#### 2.1.4.6 The State of the Art in Remote Control, Measurement and Control Systems

To summarize, it can be said that the present position in terms of remote control, measurement and control

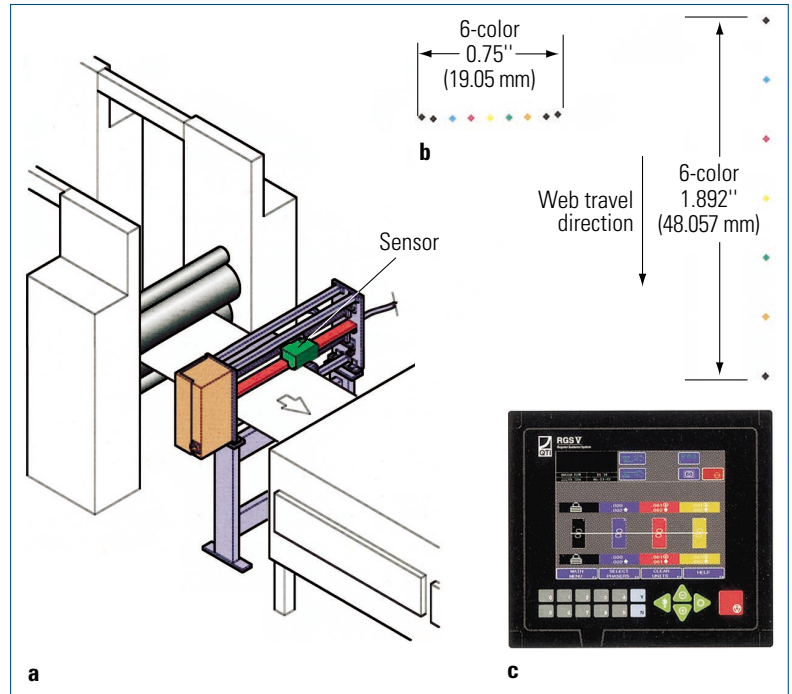
systems is as follows. Powerful measurement and control systems are available for a large variety of printing systems, from web-fed offset presses/production systems, high-quality, large size multicolor to small size, simple sheet-fed offset presses. In the last ten to fifteen years, using them in printshops has made working much easier and improved quality enormously, not to mention profitability. Print quality has become a measurable variable and the print process itself can now be measured and controlled based on objective data.

Depending on the demands print buyers make on their printers, print-quality control systems can be installed

**Fig. 2.1-148**

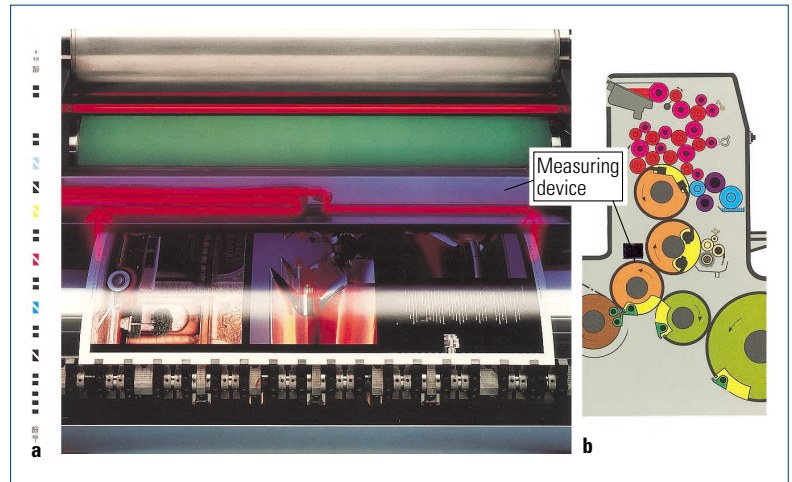
Color register measurement system for web-fed offset presses.

- a** Optical sensor fitted between the last printing unit and the dryer (contact-free web guidance in the sensor area through flow mechanical effect);
- b** Color register mark systems for multicolor printing, arranged at optionally different positions in the print area (size 1 mm × 1 mm);
- c** Monitor display with register setting controls (RGS V Air, Quad/Tech Intern.)

**Fig. 2.1-149**

In-line color register measurement and control system for sheet-fed offset press with two moveable sensors for measuring register marks in two tracks on the printed sheet.

- a** Circumferential and lateral register marks (approximately 1 × 1.5 mm<sup>2</sup>);
- b** Arrangement of sensors in the printing unit for measurements on the impression cylinder (CPC42, Heidelberg)



and tailored to meet those requirements. Whether they use densitometric or spectral measurement or off-line and/or in-line color and color register measurement and control systems depends on the quality requirements and working methods at the individual company. Either way, quality assurance calls for both control consoles with simple, reliable press settings and color and register control systems that can make both quality assess-

ments independent of the operator's subjective observations and also perform adjustments quickly and easily on the run, setting up in just a single step if possible.

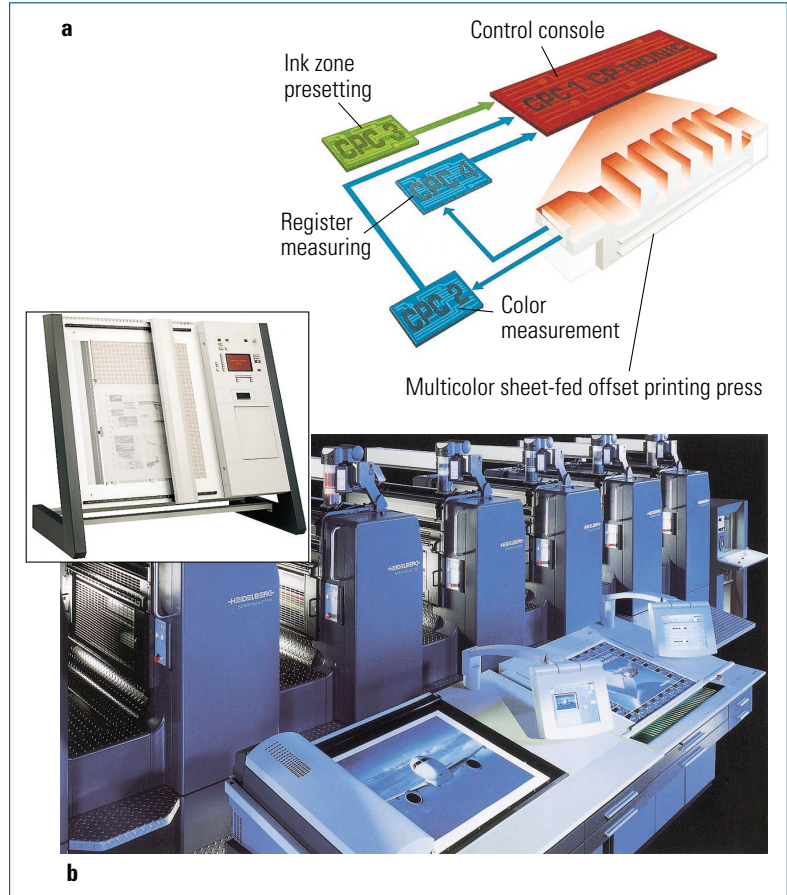
Figure 2.1-150 shows a state of the art measurement and control system for a sheet-fed offset press, together with a structure for describing the different possibilities and components for automated print quality measurement and control.

**Fig. 2.1-150**

Modular structure of a remote control, measuring and control, and presetting system for printing presses.

**a** Modular structure of a computer print control system for remote control and automation during setup, on the run and between jobs, with the components: control console (CPC1), color measurement and control (CPC2), register measurement and control (CPC4), and ink zone presetting (CPC3);

**b** Example of a sheet-fed offset press with control console, off-line color measurement and control, and image inspection system, in-line register control and ink zone presetting via prepress interface or data carrier with readings from the plate image reader (Heidelberg)



The previous sections have dealt with trends and the potential for further improvements in individual areas.

The next section will detail automation methods and what can be done with the remote control, measurement and control systems surveyed.

### 2.1.5 Automation in Print Media Production

Based on the example of offset printing, the options, methods, and systems available to automate the process of printing for longer multicolor print runs within the entire printing process is described in this section. The information given applies to sheet-fed offset as well as web-fed offset presses.

The production speed of the multicolor presses available, which is typically approximately 15 000 im-

pressions an hour for sheet-fed presses and approximately 60 000 impressions an hour for web-fed presses, is at a very high technical level, and consequently, increasing these speeds is less of a priority than efforts and measures to reduce time spent on preparing the press prior to printing production (makeready time).

The efforts to shorten the job makeready time go hand-in-hand with endeavors to minimize waste, that is, the production of unsaleable printed sheets. As already mentioned, before the production of a print job can start, the press must be set up as regards paper format, ink and, in particular, the set of printing plates. The "traces" of the preceding print run have to be eliminated first; for example, the inking units must be cleaned and the plates for the completed job removed.

Once the new plates are mounted, the feeder is supplied with the necessary paper and the ink fountains filled with the desired inks in the specified sequence for

multicolor printing, including special inks, if required. The ink feed and color register must be adjusted to the production of the print job.

The basic operations for setting up a press are illustrated in [figure 2.1-151](#). The typical time savings are shown comparing manual *preparation and makeready of the press* for the next print run with automated makeready operations. Judicious use of automated processes is bound to lead to significant reduction in makeready time. With sophisticated systems a typical four-color job can nowadays be set up in about 15 to 20 minutes as compared to a makeready time of 60 to 90 minutes for a purely manual mode of operation. The number of adjustments required to arrive at the desired ink setting, in particular, has been considerably reduced, leading to drastic reductions in waste sheets.

Another requirement on the automation of makeready is to simplify press operation for the operator, that is, to relieve him of physically demanding work, to prevent possible dangers within the production process, and to enable work to be performed in clean and environmentally friendly surroundings. The end result of all this is that the operating personnel are able to devote themselves fully to the actual specialist task, the economical and on-schedule production of consistently high-quality printed products. Technical equipment currently available largely meets such requirements.

In the following sections the individual makeready and preparatory operations are described with examples that are representative of the technologies being developed and supplied by all leading manufacturers.

### 2.1.5.1 Wash-up Procedures

In the offset printing process the inking unit, the printing plate, the blanket on the blanket cylinder, and the impression cylinder must be cleaned for each job change or interruption in accordance with operating conditions and requirements. It may even be necessary to clean the blanket cylinder during the print run, if, for example, paper dust or particles from the paper surface build up on the blanket and cause faults or defects (e.g., hickeys) during the production run. Similarly, the printing plate may also need cleaning during production, if the printing plate's surface has changed as a result of malfunctions in the dampening and inking supply or of faults induced by paper-related factors impairing printing quality. The impression cylinder may need to be cleaned, if, on the one hand, ink has been printed on it by mistake or, in the case of perfecting, if ink set-off on the surface becomes a problem.

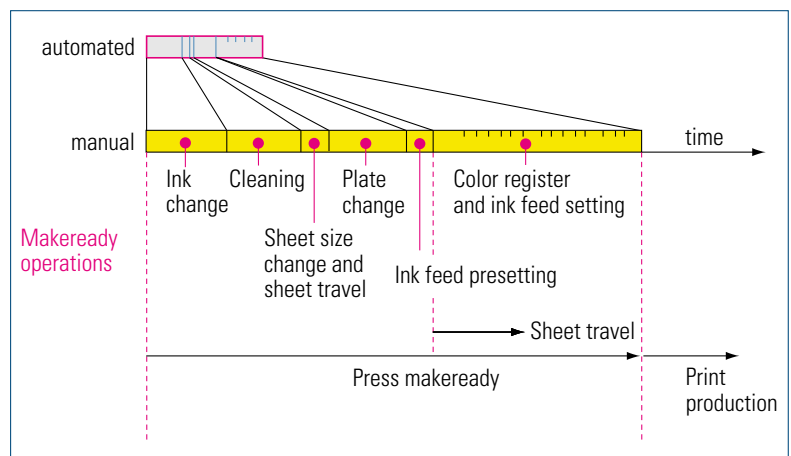
When changing a job, the ink left over from the old job must be removed from the ink fountain, if a different ink is to be used for this printing unit, such as ink for UV drying or ink of a different color.

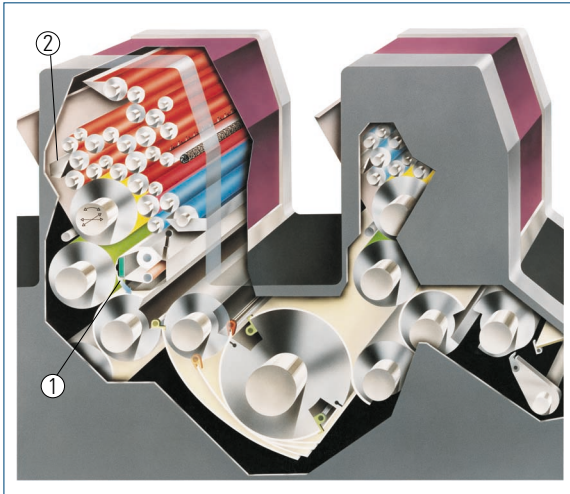
There are automated devices available to clean inking units and the cylinder surfaces referred to above. They provide technical solutions based on various design concepts with differences in effectiveness, the chemical agents required for cleaning, and the degree of automation.

The press diagram shown in [figure 2.1-152](#) illustrates how the *blanket and impression cylinders* of a sheet-fed offset printing unit can be cleaned by a single wash-up unit installed in a given position. [Figure 2.1-153](#) shows in greater detail how this system operates with regard

**Fig. 2.1-151**

The operations required for the makeready a printing press for the production of a multicolor print job (Comparison of the times taken for manual makeready procedures and makeready procedures assisted by automation)





**Fig. 2.1-152**

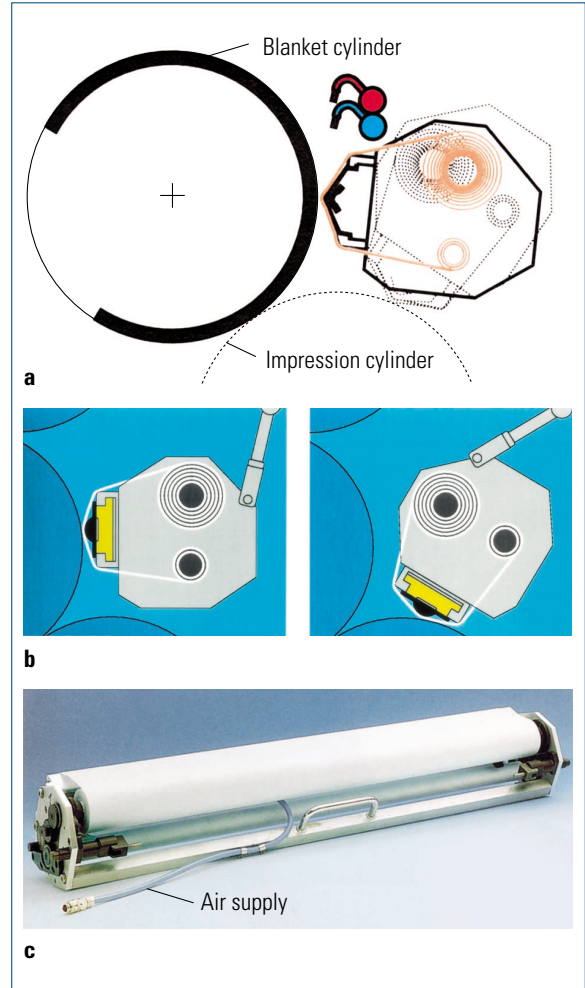
Wash-up/cleaning system for blanket and impression cylinders (1), wash-up device for inking unit (2) on the printing unit of a sheet-fed offset press (SM 74, Heidelberg)

to its wash-up position for cleaning the blanket cylinder and the impression cylinder, as well regarding advancing the cleaning cloth and pressing it against the soiled surface by means of a diaphragm that can be controlled by compressed air. The cleaning cloth width is equal to the width of the printing unit. The cleaning liquid is finely metered in accordance with the degree of soiling and sprayed onto the surfaces by nozzle rows. Used cleaning materials can be disposed of easily and to some extent recycled.

Figure 2.1-154 shows a cleaning device that cleans by means of a brush roller. The cleaning liquid is transferred to the surface via this brush roller in order to remove the dirt particles; the chemical cleaning process is assisted considerably by the mechanical motion.

Figure 2.1-154 also shows how an *inking unit can be cleaned* by a special spraying device incorporated in it. Located opposite the spraying system there is an ink trough, which is used to squeeze off the ink on a roller that is in contact with the final inking form roller (see also fig. 2.1-152). If necessary the entire inking unit can be cleaned in this way. This inking unit cleaning process can be automated, that is, supply, carrying-off, and removal of residual ink takes place via a control system. However cost/benefit calculations very often fail to justify a high level of automation.

If disruptive elements have built up on the blanket of the blanket cylinder (or on the printing plate) during



**Fig. 2.1-153** Convertible cleaning system with washing cloth.

**a** Washing cloth reel system with diaphragm (pneumatically controlled) and liquid feed for cleaning operations (two systems);

**b** Cleaning device that can be positioned on the blanket cylinder or impression cylinder;

**c** Cleaning device with compressed air supply (Heidelberg)

printing (e.g., particles of paper or dirt that show up on the printed image), there are special devices, called "*hickey removers*," which will remove the disruptive elements in a selected narrow zone of the blanket cylinder by means of a rubber blade.

### 2.1.5.2 Plate Changing

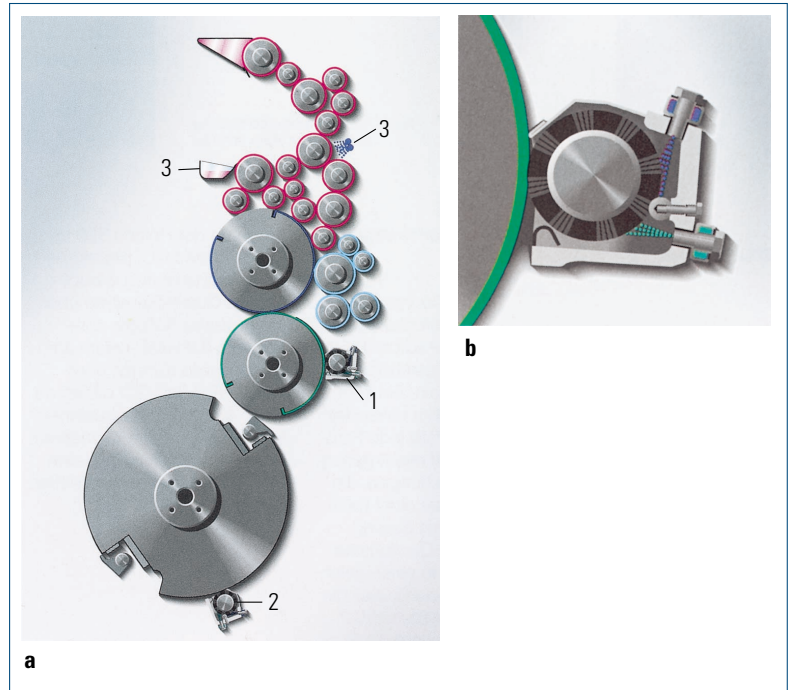
Removing the printing plates from the preceding job and mounting the printing plates for the next job can

**Fig. 2.1-154**

Automated washing equipment with cleaning brush roll.

**a** Printing unit with washing equipment for blanket cylinder (1), impression cylinder (2) and inking unit (3);

**b** Blanket wash-up device (1), (Roland 700, MAN Roland)



take place at various stages of an automated process. Plate removal and feeding operations may be performed successively for individual plates with the assistance of the operator or fully automatically by means of cassette systems with no operator intervention once the change-over process has been initiated. The first designs for automatic plate changing systems for sheet-fed presses came from Japan around 1990.

When mounting a set of printing plates for a multi-color job, it is essential that the printing plates are clamped in accurate register on the plate cylinder. This is achieved by means of the register holes on the printing plate and suitable guide systems. It implies, of course, that in prepress the color separations will have been exposed in accurate register on the printing plates.

The requirements for the reliability and efficiency of automated plate feed systems are very exacting, since accurate positioning of the plate in the printing unit can be achieved even with manual plate feed because of the high-quality register systems available in prepress and the press. The particular advantage of automatic plate feed is that no manual clamping of the plate is required, no operator-related factors are in effect, and plate change-over can take place on all printing units of the press at the same time (not always synchronously – this depends on the

cylinder arrangement and cylinder position in the several printing units regarding the cylinder gap).

Various stages of the *automated plate feeding* operation are shown in [figure 2.1-155](#). First, the plate is prepared/placed ready in the printing unit for the new job, and then the plate is placed ready for mounting on the plate cylinder, which is followed by the automatic feeding and clamping process. [Figure 2.1-155b](#) shows how the plate is fed into the plate cylinder's clamping system and how loading systems are designed.

Another system in cassette design is shown in [figure 2.1-156](#). [Figure 2.1-157](#) shows how plate removal and plate feed can be done automatically via a *cassette system*.

There are designs for an automatic plate change, where the printing plates for several jobs can be stored in one cassette in the correct sequence. This means that the plates for several successive jobs can be ejected and loaded automatically. Such a system is shown in [figure 2.1-158](#). However, these multi-plate cassette systems might prove to be troublesome in the case of malfunctions or if rescheduling measures have to be taken on short notice, for example changes in the press assignment or the processing sequence of orders.

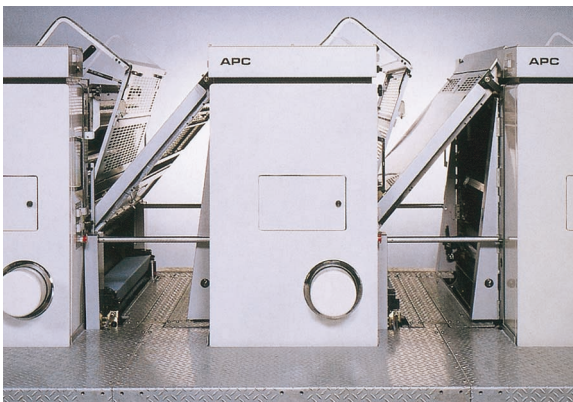
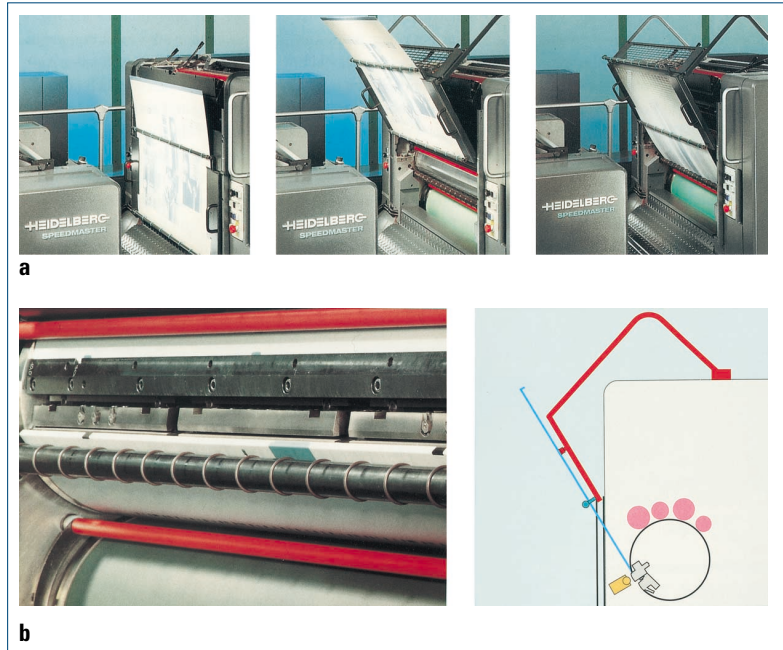
Automated plate changing systems are also used on web offset printing systems. [Figure 2.1-159](#) gives an ex-



**Fig. 2.1-155**

Automated plate feed on the printing unit of a sheet-fed offset press.

**a** Feeding the plate;  
**b** The structural design of a plate clamping mechanism (SM 102/Autoplate, Heidelberg)

**Fig. 2.1-156**

System for automated printing plate change on a sheet-fed offset press (Lithrone/APC, Komori)

ample of how the plates for the upper and lower printing unit/couple on a blanket-to-blanket unit are changed by means of a cassette system.

### 2.1.5.3 Sheet Size and Paper Travel Adjustment

The feeder and delivery of a sheet-fed offset press have to be adjusted if there is a *change of paper format* from

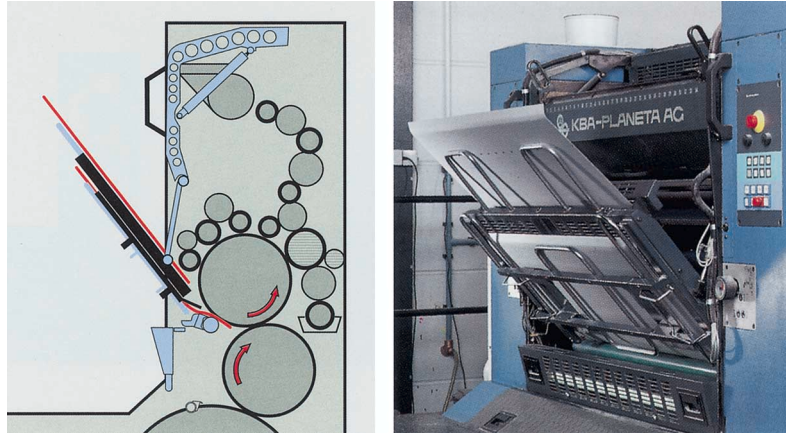
one job to the next. The positioning of the paper pile in the feeder and the setting of the suckers to pick up the sheet and transport it into the first printing unit, as well as the sheet guidance and alignment elements on the feeding table (guide rollers, front and side lays), all need to be adjusted. The blast and suction air systems that support paper travel must likewise be set to the new format. With present-day technologies for remote adjustment and position measurement this procedure can be automated. For example, the format specifications can be entered on the press control console and the paper guiding elements repositioned as a result of this. This is possible for both sheet feeders and sheet deliveries.

Figure 2.1-160b shows a sheet feeder with a suction head together with a display on the operator's control panel (fig. 2.1-160c), from where the paper format, as well as the adjustments required as a result of a different paper thickness, can be set by remote control or automatically in the feeder area. Figure 2.1-160a shows the infeed process over the feed table to the first printing unit. The sheet guidance elements and the stops for aligning the sheet before it is taken over by the feed system to the first printing unit are adjusted by remote control.

On *perfecting presses*, which can print both sides of a sheet in one sheet pass, both the gripper system of the

**Fig. 2.1-157**

Automated change of printing plate using a cassette for plate removal and plate feed for the next job on the printing unit of a sheet-fed offset press (Rapida 105, KBA)

**Fig. 2.1-158**

Fully-automatic printing plate change on a 4-color sheet-fed offset press with multi-plate cassette system (SM 102/Multiplate, Heidelberg)



sheet reversing unit and the suction systems must be adjusted to the sheet size when the press is converted from straight printing to perfecting. Depending on the structural design of the press, this can be a very time-intensive and demanding manual process. More recent press engineering solutions provide the means for an automated, easy, and safeguarded adjustment by the operator.

Long print runs on highly productive sheet-fed offset presses necessitate multiple *pile changes*, which means that press stoppages and restarts to change the

piles are inevitable; yet feeders making possible a fully automatic pile change have been developed for sheet-fed offset presses. A feeder of this type is shown in [figure 2.1-161](#). The almost empty pallet can be taken over by a special rake system ([fig. 2.1-161b](#)) and a new pile can be loaded underneath. The sequences for changing the corresponding pallet-carrying systems run automatically. Systems of this kind are explained in greater detail in [sections 2.1.2.8 \(figs. 2.1-69, 2.1-70\)](#) and [8.1.1.5](#). With devices such as these, a sheet-fed offset press can operate non-stop for the entire print run, in a similar



**Fig. 2.1-159**  
Automated printing plate change on a web offset printing system (M-600, Heidelberg)

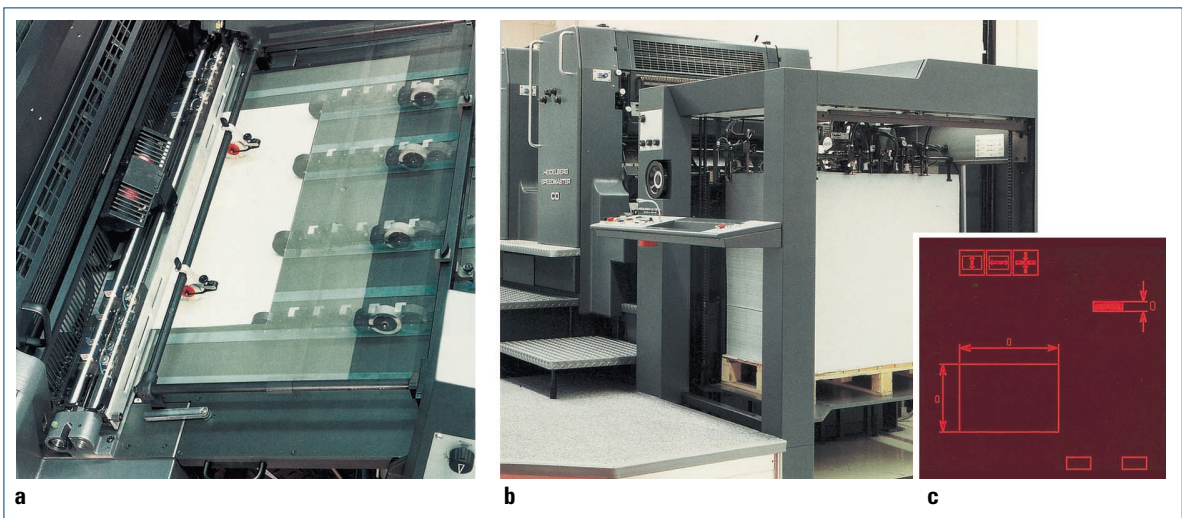
way to web offset presses. Naturally, the rather high investment for such systems must be justified by the printing company's customer and order profiles.

The paper guidance in the delivery, that is, the format-related mechanical components and the supporting blast and suction air systems, can also be adjusted by remote control. Drying units and powdering devices installed in the delivery section can also be adapted to the paper format with the support of automatic features.

#### 2.1.5.4 Ink Feed Presetting in the Printing Unit

If the register systems for mounting the printing plate are accurate and the preceding platemaking operations for the individual color separations have been performed in accurate register, no special presetting is required for the color register – fine adjustment can be done in a few steps after the first sheet has been printed.

This is not the case for the ink feed for inking up the printing areas on the printing plate. The ink feed to the individual printing units through the zonally divided ink fountains (see also [fig. 2.1-158](#)) depends on how much of the printing plate surface is occupied by image areas. Each ink zone has to be set to the corresponding area coverage of an ink-zone-wide strip on the



**Fig. 2.1-160** Automated sheet size adjustment at the feeder of a sheet-fed offset press.  
**a** Feed table and sheet feeding to the first printing unit;  
**b** Feeder with paper pile and suction head and equipment for sheet separation and transport to the feed table with control panel;  
**c** Display for operator guidance fitted on the control panel (SM 102, Heidelberg)

**Fig. 2.1-161**

Non-stop feeder for automatic pile change for sheet-fed offset presses.

- a** Non-stop feeder with pile rake in neutral position;  
**b** Pile rake in action, taking over the residual pile for a pallet change (Autopile, Heidelberg)

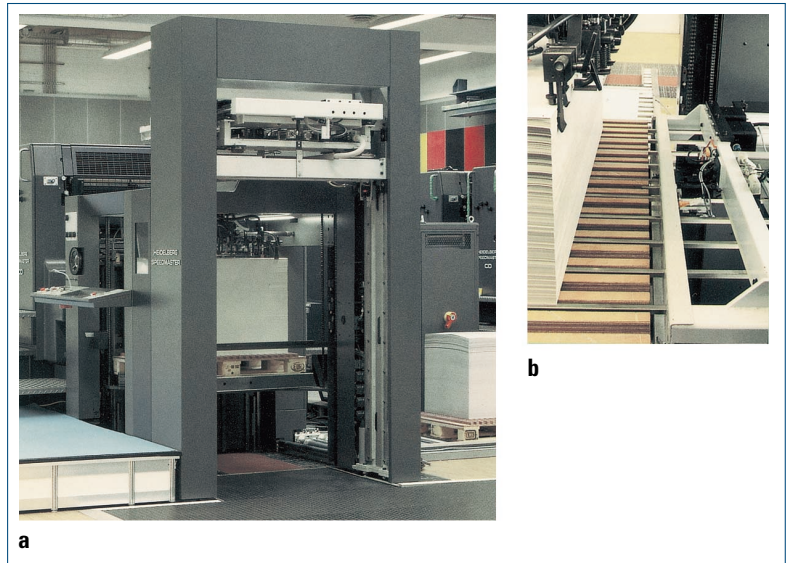


plate in the direction of printing. The ink strip width, which affects all ink zones, is adjusted to the printing plate through the angle of rotation of the ink fountain roller (e.g., based on the mean value of the area coverage). Therefore adjustment of the ink strip width and the ink-zone opening must be done printing unit by printing unit (see also [figs. 2.1-13](#) and [2.1-126](#)).

This is a time-consuming process, if the operator has to set the ink zones directly on the ink fountain manually and printing unit by printing unit. Furthermore it is a very imprecise method, which very much depends on the experience of the press operator, the quality of his visual assessment of the zonal ink requirement, and the resultant setting of the zone opening. Even though ink-zone adjustment by remote control via the press control console has been possible for a long time, quantitatively accurate presetting had still not been achieved. A fundamental step towards a reduction in makeready times was the development of so-called *plate image readers*, with which the zonal ink requirement of the printing plate could be measured automatically before the plate was mounted in the printing unit; the first systems came on the market around 1982 (e.g., DEMIA from Dainippon Printing and CPC3 from Heidelberg; see also [sec. 2.1.4.1](#) and [fig. 2.1-127](#)).

A *plate image reader* of this kind is shown in [figure 2.1-162](#). An optical scanning system measures the mean percentage area coverage within the ink zone on the

**Fig. 2.1-162**

Plate image reader for determining the zonal ink requirement of an offset printing plate for ink feed presetting (CPC 31, Heidelberg)

basis of the different reflection behavior of ink-accepting and ink-free surfaces (solid area corresponds to 100%). The settings for the ink zone opening and the ink stripe width of the ink fountain are determined on the basis of an algorithm that takes into account the inking unit design, print characteristic curve, and the effects of ink and paper. The data can either be trans-

ferred directly to the press via a data line, or preferably, handed over to the printer on a data carrier (e.g., a flash card that can typically store approximately fifty four-color jobs) together with the other information for the print job. The ink feed on all printing units can be preset on the basis of these data, before the plates are mounted and paper travel is started in the press. Other settings can be deduced from the ink requirement and the ink distribution on the printing plate, for example the starting position of the distributor rollers in the inking unit in relation to the plate cylinder gap and the amount of dampening solution required for the print job.

Digitization has provided prepress with the option of specifying the print job in an entirely digital form, which means that the area coverage of the individual color separations can be calculated zone by zone from the data file specifying the entire contents of the printed sheet of the job to be printed, in which case a plate image reader is not required. Calculating ink presetting using the print image data from prepress is an example of the application of a *prepress interface* (as discussed in greater detail in [sec. 8.2.3](#), see also [figs. 8.2-12, 8.2-13](#)). Information for presetting the press, and in particular the ink feed, is transferred via this interface using a special data format (PPF: print production format). [Figure 2.1-163](#) shows on screen how the area coverage values in the different ink zones have been calculated from the individual color separations for the entire print image for the process colors black, cyan, magenta, and yellow. The calculation and setting of the ink zone open-

ings and ink stripe widths can preferably be done on the computer in the control console, taking the particular press characteristics into account.

With conventional offset printing, the printing unit must be *supplied with a dampening solution* in addition to the ink; the dampening solution feed has to be set, too. The necessary dampening solution feed requirement can be roughly calculated from the print-job-related ink requirement, and presetting for the dampening solution feed can be derived from this in accordance with the type of dampening unit used. Zonal feeding of the dampening solution is not usually necessary; setting a mean value from the dampening ductor speed will suffice for the application of the thin film of dampening solution onto the printing plate. With current continuous-type dampening systems a film of 1 to 2  $\mu\text{m}$  is sufficient. (For special applications inking units can be equipped with blast air units by means of which a special dampening solution profile can be achieved.) Therefore the dampening ductor speed can be set together with the presetting data for the ink zones.

How much ink is in fact transferred to the printing plate is dependent on numerous factors influencing the ink flow in the printing unit. Among the decisive ones are the fluid dynamic processes involved in the transfer of the ink from the ink fountain to the roller system, the ink splitting processes and the ink flow in the vicinity of the individual zones, and the phase relation of the lateral distribution (starting position of the *lateral distribution* in relation to the plate cylinder gap). The dampening solution also has an effect on the ink-water emulsion. Trans-

**Fig. 2.1-163**

Determining the zonal area coverage for offset printing plates from the data file specifying the entire multicolor print sheet (Prepress Interface CPC 32/CIP3-PPF, Heidelberg)



fer from the ink form rollers to the printing plate, from the printing plate to the blanket, and then from the blanket to the paper, are similarly affected by the characteristics of the materials and the mechanical tolerances and printing pressure settings in the printing unit. The *optimum* provided by theoretical assessment of the ink zone presetting merely on the basis of the ink requirement will only be an approximation to the actual ink feed during production. Systems using special *learning algorithms* can, as a result of the differences between the presetting and the final setting values during production, produce better presettings for the subsequent print jobs. *Self-learning, adaptive systems* of this kind contribute a lot to the success of ink presetting. Furthermore, ink presetting is based on certain default values. Should the print job, however, not correspond to standard parameters, it must be possible to adapt the ink presetting accordingly by entering the relevant characteristic curves or parameters.

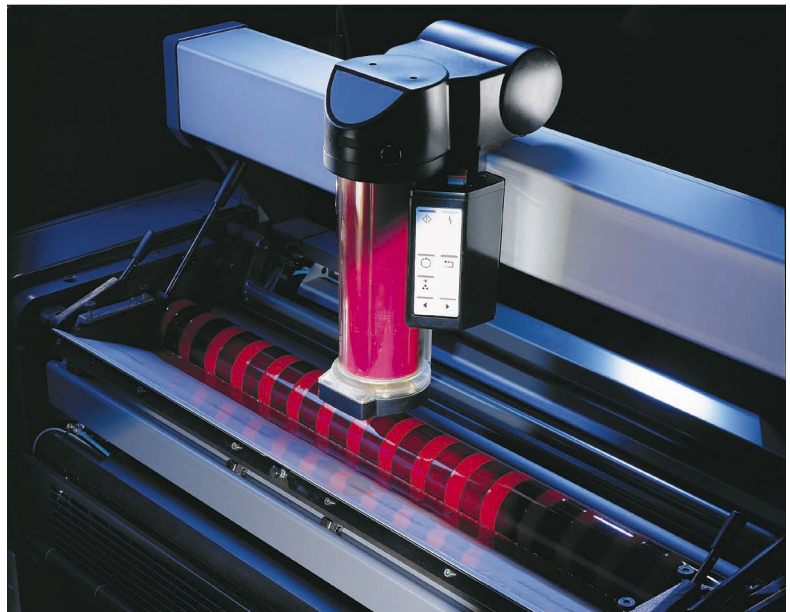
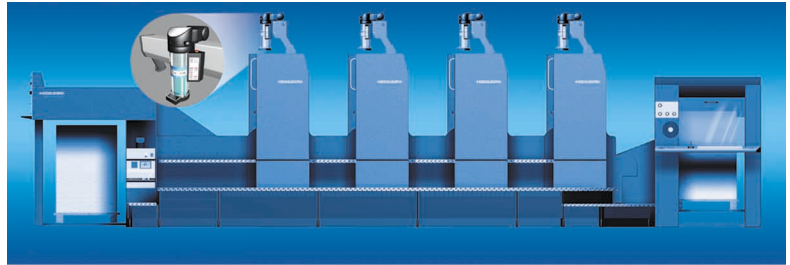
### 2.1.5.5 Ink and Dampening Solution Supply

To fill the ink fountains on sheet-fed offset presses with ink, the operator will normally use just a spatula to transfer the ink from the ink can directly into the ink fountain.

There are systems available offering an even simpler and more convenient method of filling up the ink fountains on sheet-fed presses; *ink cartridges* are used to perform the automatic fill-up procedure. [Figure 2.1-164](#) shows an ink cartridge holder that moves automatically from side to side to ensure that the ink fountain is evenly filled up with ink. The filling level is recorded by a sensor (e.g., ultrasonic sensor) and topping up is initiated via a control system. This type of cartridge system is operator-friendly and the automation and monitoring technology associated with it ensure that the operator is informed of the ink reserve status throughout the print run.

**Fig. 2.1-164**

Automatic ink fill-up system for the ink fountain on a multicolor sheet-fed offset press (InkLine, Heidelberg/ Technotrans)



The automatic ink supply in conjunction with filling-level monitoring and control systems in the ink fountain have long been state of the art on web offset presses, because of their far higher productivity and print run length. Figure 2.1-165 shows how the ink is supplied to the ink fountains of a web offset press by means of *ink pumps* and piping systems. An ultrasonic sensor, which is used to measure and control the filling level, can also be seen. Similar ink supply systems are also occasionally used in sheet-fed presses.

There are also measuring and control systems for the *dampening solution supply*; they ensure that there is always an adequate amount of dampening solution in the dampening fountain on the printing unit, but above all they monitor the composition of the dampening solution and guarantee by means of metering systems that the correct concentration is maintained. Automated dampening solution systems of this kind are also equipped with temperature control units to keep the dampening solution at a constant temperature.

### 2.1.5.6 Makeready for Print Production

After completion of the various cleaning processes, presetting the units for paper and ink feed as well as changing plates, the final step in the preparation of the press for the next print job can take place, that is, fine adjustment during paper travel.

Like the preparatory operations prior to paper travel, this can be done straightforwardly, simply, and quick-

ly from a *central control console*, as illustrated in figure 2.1-166 for a sheet-fed offset press with ten printing units. All press functions are displayed on a monitor and adjustments can be initiated directly from there. The control console has a special ink-zone keyboard for remote control of the ink feed. As shown in figure 2.1-166, the operator can assign the printed image and the ink zones to one another, which means that he is able to make specific fine adjustments to the ink feed by visual inspection or with the help of hand-held measuring instruments. The fine adjustment for the *color register* and the printed *color* is supported and/or automated with the help of measuring and control systems as already explained in section 2.1.4.

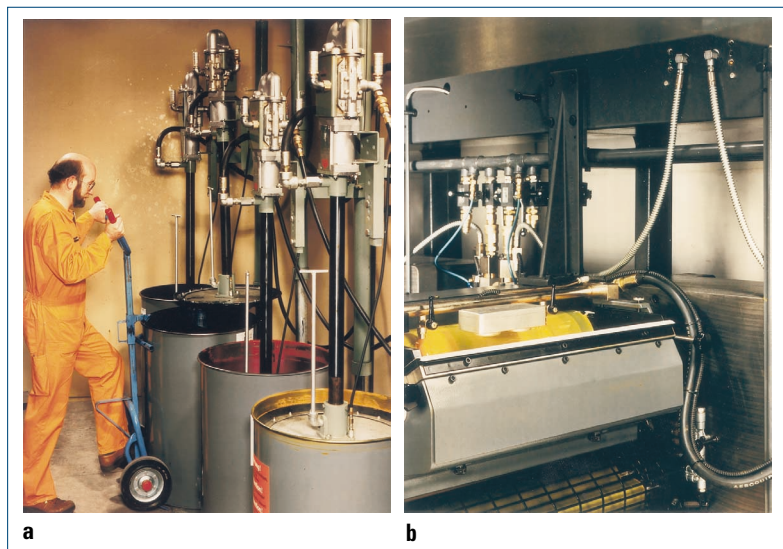
The multicolor offset press shown in figure 2.1-167 serves as an example of the use of electronic and optical measurement systems, such as the scanning of the printing plate by a plate image reader for ink presetting, the electronic register mark reader for measuring and controlling of color registers, and the spectral measurement and control system for setting the ink feed to the specified color values and maintaining the print quality throughout the entire print run, in addition to the central control console.

The preparatory operations prior to paper travel in the press described above lead to considerable savings on paper waste, compared to older methods without automation technology. At the *start of printing* and of the paper travel, the inking unit must be brought into a

**Fig. 2.1-165**

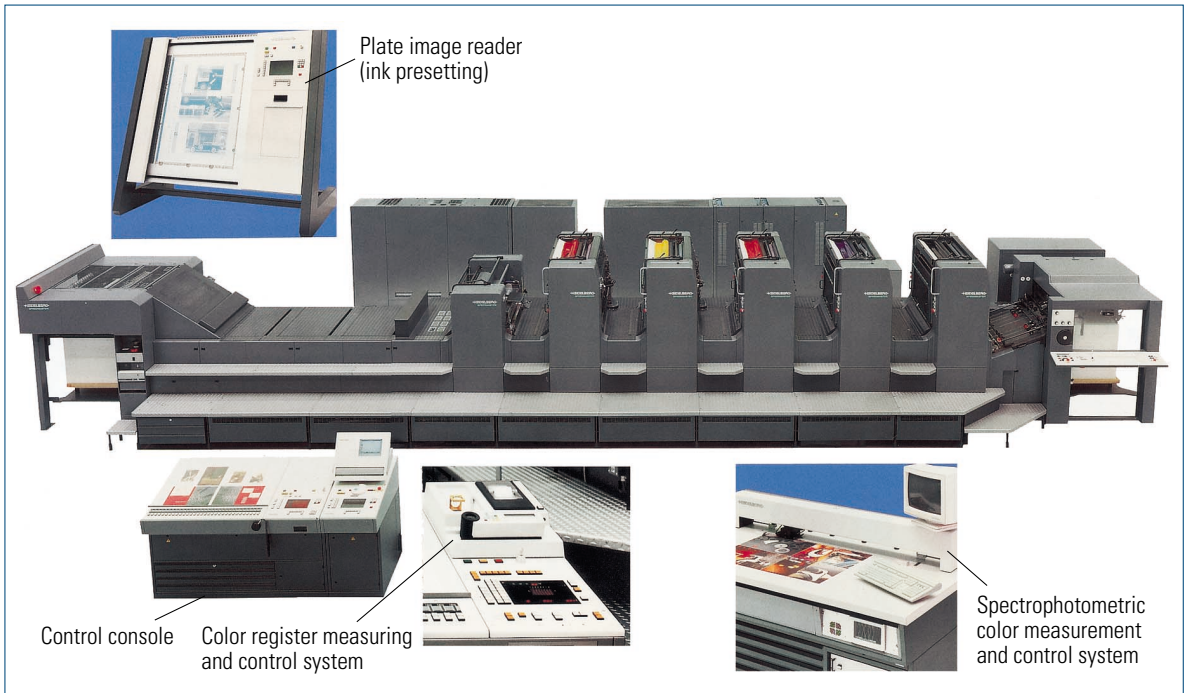
Automatic ink supply for a web offset press (around 1982).

- a** Ink container with ink pumps and supply system;
- b** Ink fountain with ink supply pipe and filling level monitoring (Web 8, Heidelberg)



**Fig. 2.1-166**

Central control console for the remote control of a 10-color sheet-fed offset press (SM 102/CP 2000-System, Heidelberg)

**Fig. 2.1-167**

Multicolor sheet-fed offset printing system with central control console and measurement and control systems for ink presetting, color register and ink feed/color (CPC-System, Heidelberg)



steady condition in accordance with the ink feed pre-setting parameters. Because of the generally large number of ink rollers in an inking unit this is a relatively tedious process; a virtually steady condition is only reached after approximately 150 revolutions of the plate cylinder and the transfer of ink onto the paper. This would mean that a large number of waste sheets would be printed before measurements can be taken for adjustment of the ink supply. There are now methods (algorithms in particular) by means of which the response time of the printing unit/the ink flow until a stable state can be accelerated. There are algorithms controlling the ink flow by means of which more ink is fed into the inking unit for a short, specified period, and only then are the ink zone openings set to the values required for steady production (e. g., dead-beat processes).

Fine adjustment during paper travel generally takes place at a printing speed lower than *production speed*. The acceleration of the press to production speed might change the ink feed ratios, in particular. This can be compensated for by means of powerful computer-aided control systems. The dampening solution supply system, the blast-air and suction-air devices and perhaps even the control of the drying units are also adjusted in accordance with the speed.

Figure 2.1-168 shows the display options of the *control console* depicted in more detail in figure 2.1-167. The set-

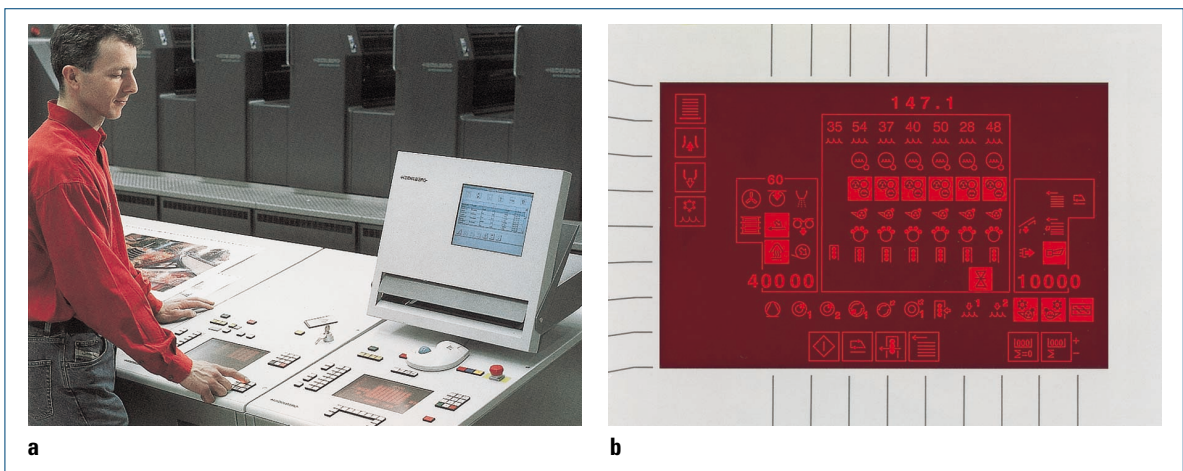
tings in the printing units, in the feeder and delivery are displayed on screen at the control console. The press operator is provided with concise information by means of pictograms. The display can be switched over to focus on particular press setting operations to be performed.

The monitor on the control console (as shown in fig. 2.1-168) is one component of a *production and information system*. Data can be transferred via a network, not only from the pressroom, but also from the prepress department. Production planning, press utilization and job scheduling data can be displayed, and up-to-date job status messages can also be called up to assist the operator.

The equipping of production systems with the aforementioned components for automation, production-control and monitoring is virtually state of the art.

Figure 2.1-169 gives an overview of system configurations from various manufacturers including components for remote control and measurement and control technology for the efficient, economical operation of presses, as well as elements for networking the entire production flow.

Chapter 8 describes in detail the material logistics and data flow within the press area, within the entire printing company, and in relation to central networking. In particular, an explanation is given of the logistics components for materials conveyance and the automation of the latter.



**Fig. 2.1-168** Control console for the remote control of a sheet-fed offset press.

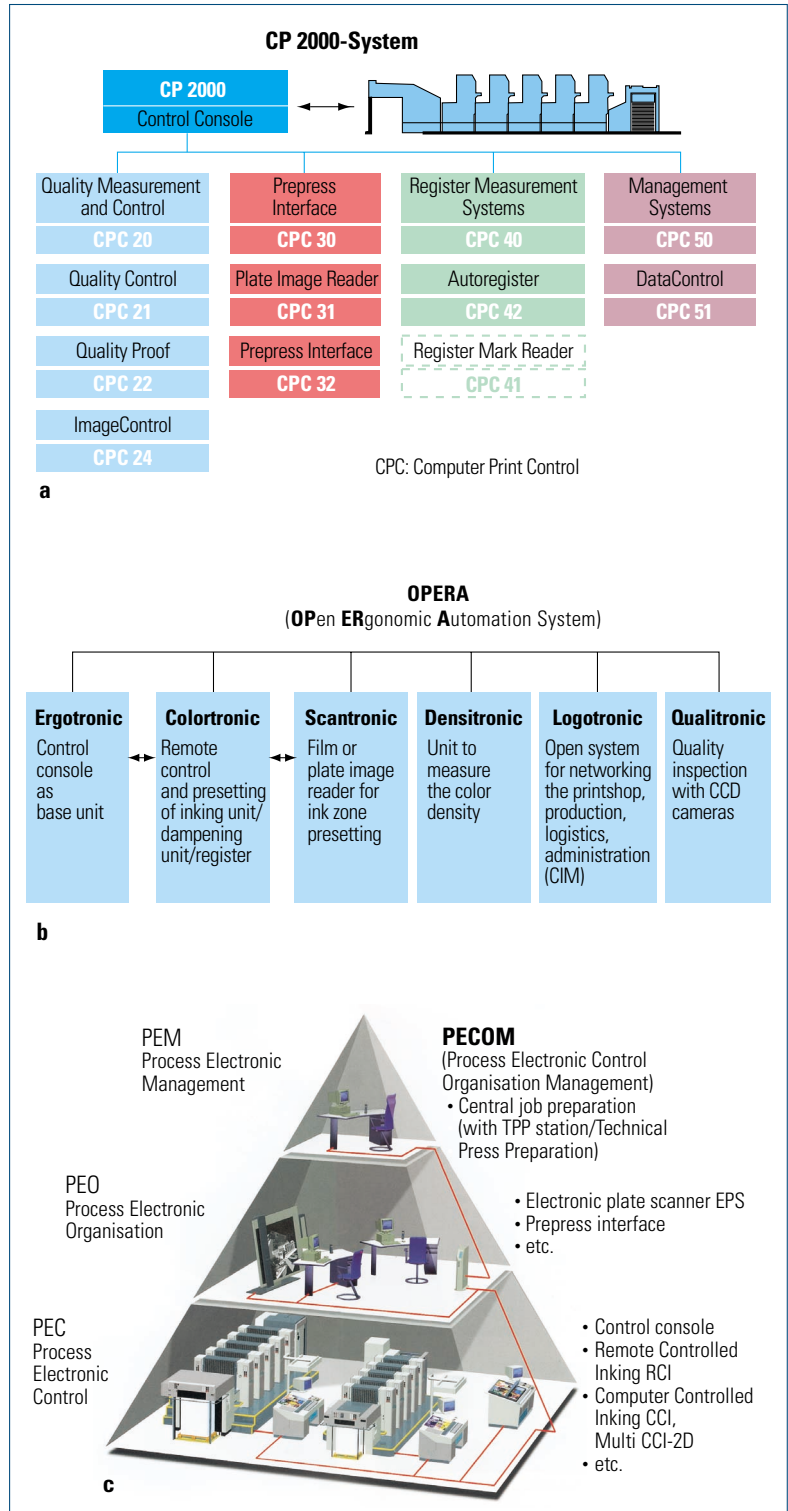
**a** Control console (CPC 1) with press status display (the display is integrated in the control console) and monitor for the production and information system (DataControl);

**b** Display, integrated in the control console displaying information/settings on the feeder, printing units and delivery (CPC-System, Heidelberg)

**Fig. 2.1-169**

System components for automation, measurement and control technology, networking and logistics around the printing press.

- a** CP 2000 System (Heidelberg);
- b** OPERA System (KBA);
- c** PECOM System (MAN Roland)



## 2.1.6 Examples of Offset Printing Presses and Production Systems

### 2.1.6.1 Sheet-fed Offset Printing Presses

The previous chapters and [section 2.1.2](#) in particular dealt principally with press concepts and individual press components. The following examples represent a selection of sheet-fed offset press configurations from various manufacturers that are currently used in the printing industry. This is in addition to the examples given in [sections 2.1.4](#) and [2.1.5](#).

Sheet-fed offset presses are grouped according to *sheet size classes and sheet size ranges*, that is, by the maximum printable sheet size ([tables 2.1-3](#) and [2.1-4](#)). Other significant *attributes* are:

- range of application (substrate, print quality, market sector, etc.),
- productivity,
- level of automation,
- arrangement of cylinders/sheet travel,
- operation,
- flexibility (sheet size, perfecting),
- physical size.

Sheet size class	Print format (approximate value in inches)	
00	up to 35 cm × 50 cm	(13 <sup>3</sup> / <sub>4</sub> × 19 <sup>5</sup> / <sub>8</sub> )
01	46 cm × 64 cm	(11 <sup>1</sup> / <sub>8</sub> × 25 <sup>1</sup> / <sub>8</sub> )
0b	50 cm × 70 cm	(19 <sup>5</sup> / <sub>8</sub> × 27 <sup>1</sup> / <sub>2</sub> )
1	56 cm × 83 cm	(22 × 32 <sup>5</sup> / <sub>8</sub> )
2	61 cm × 86 cm	(24 × 33 <sup>7</sup> / <sub>8</sub> )
3	65 cm × 96 cm	(25 <sup>5</sup> / <sub>8</sub> × 37 <sup>3</sup> / <sub>4</sub> )
3b	72 cm × 102 cm	(28 <sup>3</sup> / <sub>8</sub> × 40 <sup>1</sup> / <sub>8</sub> )
4	78 cm × 112 cm	(30 <sup>3</sup> / <sub>4</sub> × 44 <sup>1</sup> / <sub>8</sub> )
5	89 cm × 126 cm	(35 × 49 <sup>5</sup> / <sub>8</sub> )
6	100 cm × 140 cm	(39 <sup>3</sup> / <sub>8</sub> × 55 <sup>1</sup> / <sub>8</sub> )
7	110 cm × 160 cm	(43 <sup>3</sup> / <sub>8</sub> × 63)

**Table 2.1-3** Sheet size classes for sheet-fed offset presses

Presses in the *70 cm × 100 cm sheet size range* with four to six printing units and at least one sheet reversing device are classed as all-round printing presses and are very flexible in their application. [Figures 2.1-170](#) through [2.1-175](#) show different printing presses of this kind from various manufacturers.

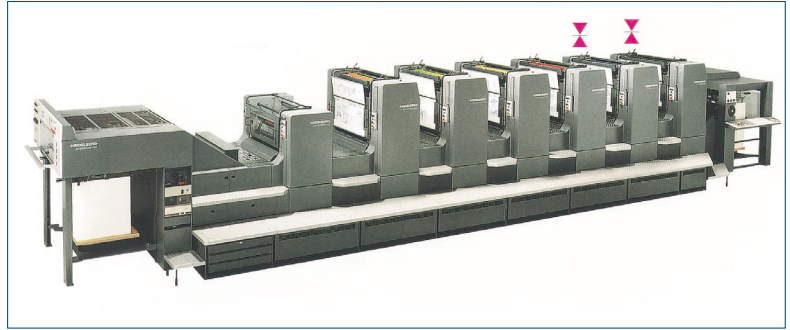
Sheet size ranges		Maximum sheet size of the press* (max. print format)	Corresponding standard formats (DIN/ISO)			
cm	inch (approx.)		A formats mm	inch (approx.)	B formats mm	inch (approx.)
35 × 50	14 × 20	370 × 520 (360 × 520)	A3 (2 × A4) 297 × 420	11 3/4 × 16 1/2	B3 353 × 500	12 7/8 × 19 5/8
50 × 70	20 × 28	520 × 740 (510 × 740)	A2 (4 × A4) 420 × 594	16 1/2 × 23 3/8	B2 500 × 707	19 5/8 × 27 7/8
70 × 100	28 × 40	720 × 1020 (700 × 1020)	A1 (8 × A4) 594 × 841	23 3/8 × 33 1/8	B1 707 × 1000	27 7/8 × 39 3/8
> 70 × 100 e.g. 100 × 140	> 28 × 40 40 × 55 1/8	1020 × 1420 (1010 × 1420)	A0 (16 × A4) 841 × 1189	33 1/8 × 46 3/4	B0 1000 × 1414	39 3/8 × 55 5/8

\* Substrate format that can be printed/fed in the press; printable format reduced in direction of print due to gripper margin (examples, depend on mode manufacturer).

**Table 2.1-4** Format ranges for sheet-fed offset presses and the corresponding substrate and printing formats (selection)

**Fig. 2.1-170**

Speedmaster SM 102 with six printing units, coating unit and high-pile delivery. The fact that sheet reversal can take place after the first or second printing unit increases flexibility; sheet size 720 mm × 1020 mm, printing speed 13000 impressions/hour, printing unit diagram see [fig. 2.1-37](#) (Heidelberg)

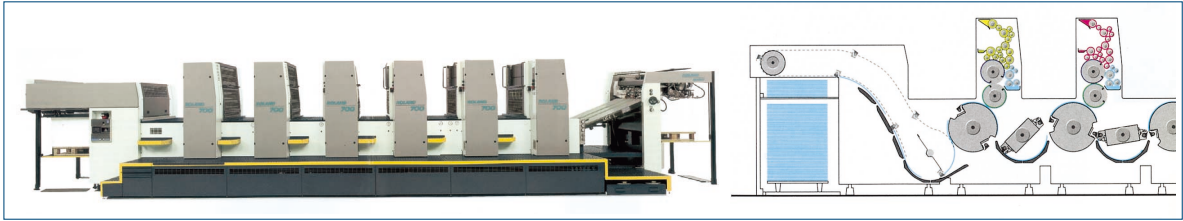
**Fig. 2.1-171**

CD model of the Speedmaster SM 102 (for cardboard printing), 6-color press with coating unit and extended delivery, with double-size impression cylinders and triple-size transfer drums; sheet size 720 mm × 1020 mm, printing speed 15000 impressions/hour, see press diagram [figure 1.6-5c](#) (Speedmaster CD 102-6+L(X), Heidelberg)

**Fig. 2.1-172**

Rapida 105, 4-color press, with 2/2 sheet reversal; sheet size 720 mm × 1050 mm, printing speed 15000/12000 impressions/hour, reduced speed for perfecting, see press diagram [figure 1.6-5b](#) (KBA)



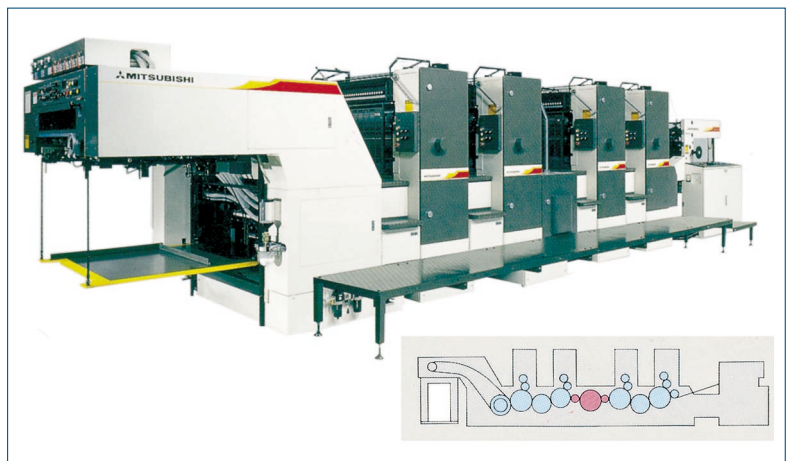


**Fig. 2.1-173** Roland 700, 6-color press; sheet size 740 mm × 1040 mm, printing speed 15000 impressions/hour (MAN Roland)



**Fig. 2.1-174** Lithrone 40, 6-color press, two coating units, unit for intermediate drying, hot-air extraction in the delivery; sheet size 720 mm × 1030 mm, printing speed 15000 impressions/hour (Komori)

**Fig. 2.1-175** Model 3FR-4, 4-color press with sheet reversal for 2/2 printing; sheet size 720 mm × 1020 mm, printing speed 13000/11000 impressions/hour, reduced speed for perfecting (Mitsubishi)



“Large format presses” (sheet size up to approximately 120 cm × 162 cm) are typically used for the printing of packaging (folding boxes), large posters, and maps. Figure 2.1-176 shows an example of this kind of press, (other manufacturers are KBA or Komori, for example).

There are also sheet-fed offset press configurations in unit construction in the 70 cm × 100 cm format range with more than six printing units. *Eight-color presses* for 4/4 double-sided printing are particularly popular, but there are also configurations with ten and twelve print-

ing units (status 2000), so that with 4/4 double-sided prints, one or two additional spot colors can be printed (fig. 2.1-177).

The following figures 2.1-178 through 2.1-182 show a selection of presses from various manufacturers in the 50 cm × 70 cm sheet size range.

The small format sheet-fed offset printing presses in the 35 cm × 50 cm sheet size range have the greatest diversity. These range from highly automated presses for single and multicolor printing to simple single color

**Fig. 2.1-176**

Roland 900 in a press room; sheet size 1020 mm × 1420 mm, printing speed 12000 impressions/hour (MAN Roland)



**Fig. 2.1-177**

Speedmaster SM 102 with ten printing units, perfecter after the fifth printing unit; sheet size 720 mm × 1020 mm, printing speed 12000 impressions/hour, CP 2000 control console for remote control (Heidelberg)



**Fig. 2.1-178**

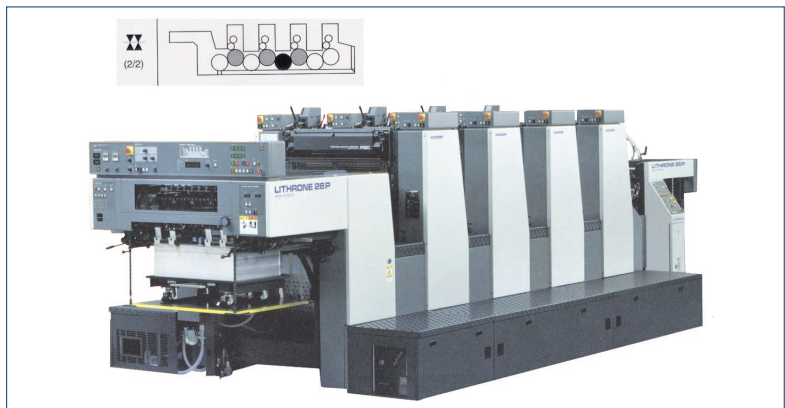
Speedmaster SM 74 with eight printing units, perfector after the fourth printing unit; sheet size 530 mm × 740 mm, printing speed 15000 impressions/hour, press diagram see [fig. 1.6-5a](#) (Heidelberg)

**Fig. 2.1-179**

Roland 300, 4-color press, sheet reversal; sheet size 530 mm × 740 mm, printing speed 15000 impressions/hour (MAN Roland)

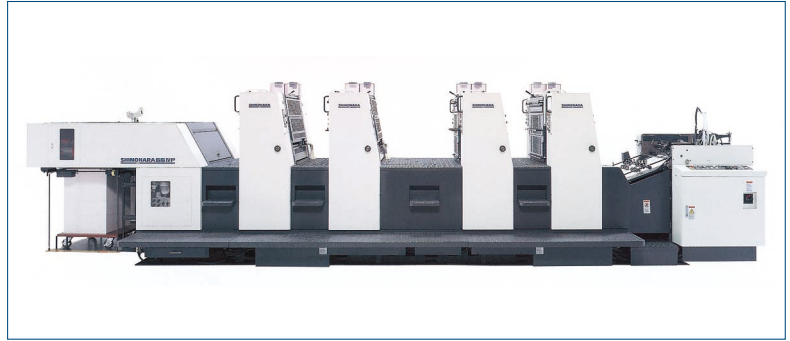
**Fig. 2.1-180**

Lithrone 26 P, 4-color press with 2/2 sheet reversal; sheet size 480 mm × 660 mm, printing speed 15000/13000 impressions/hour, reduced speed for perfecting (Komori)

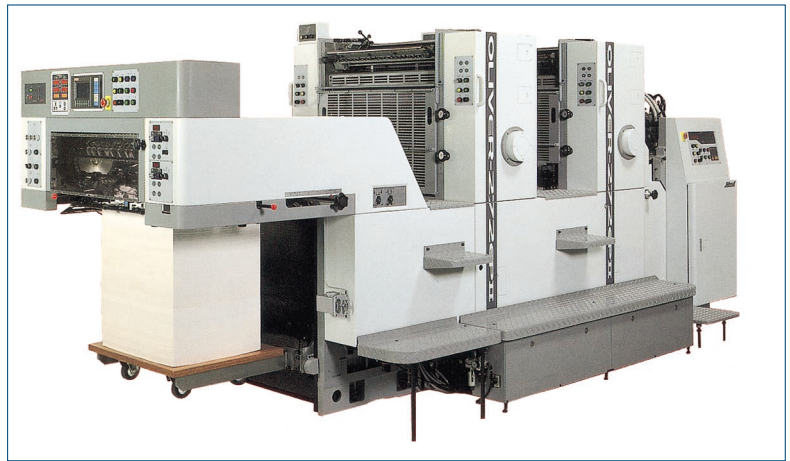


**Fig. 2.1-181**

Shinohara 66 IVP, 4-color press with sheet reversal. Printing units 1 and 2 are connected by a double-size transfer cylinder, as are printing units 3 and 4. Sheet reversal with a 3-drum system after the second printing unit; sheet size 483 mm × 660 mm, printing speed 13000 impressions/hour (Shinohara)

**Fig. 2.1-182**

Oliver-272EPII, 2-color press with sheet reversal; sheet size 520 mm × 720 mm, printing speed 12000/10000 impressions/hour, reduced speed for perfecting (Sakurai)



presses. Sheets can be printed in both the landscape and portrait format. This type of press is predominantly used for short print runs and special printing materials.

Numbering and perforating devices are often used on these presses. Figures 2.1-183 through 2.1-187 show just a small selection of presses.

### 2.1.6.2 Web-fed Offset Printing Presses/Systems

In section 2.1.3 are described web-fed presses primarily according to their individual units and components. This chapter will illustrate and outline the complete production systems combined from the individual sub-assemblies. The examples given are shown in diagrammatic form or complete systems as they are installed in printing companies.

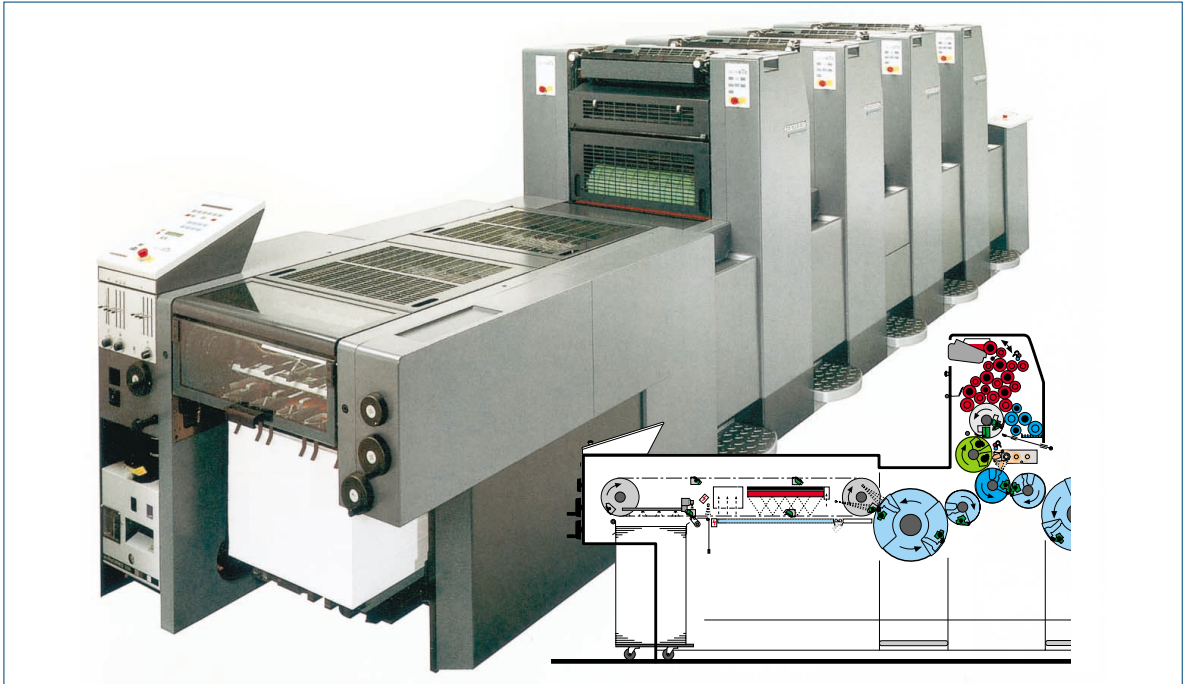
A collection of examples of *commercial web-fed offset printing systems* is shown in figure 2.1-188, mainly for single web operation. Figure 2.1-188b shows a two-web

offset printing system, in which the printing units are arranged in line and the two hot-air dryers are placed above each other.

Figure 2.1-189 shows a commercial web offset printing system equipped with eight blanket-to-blanket printing units (2 × 24 pages), in which the printing units for the two webs, together with dryers, chill rolls and slitting unit, are *stacked*. After the webs have passed through the turner bar section, they are fed into the “pinless former folder” (PFF) and the finished printed product is delivered. The folder and control station are encased in noise protection walls. This two-tiered design produces a compact, short, space-saving web-fed printing press/system. Forty-eight page presses are predominantly used to print signatures for periodicals and books.

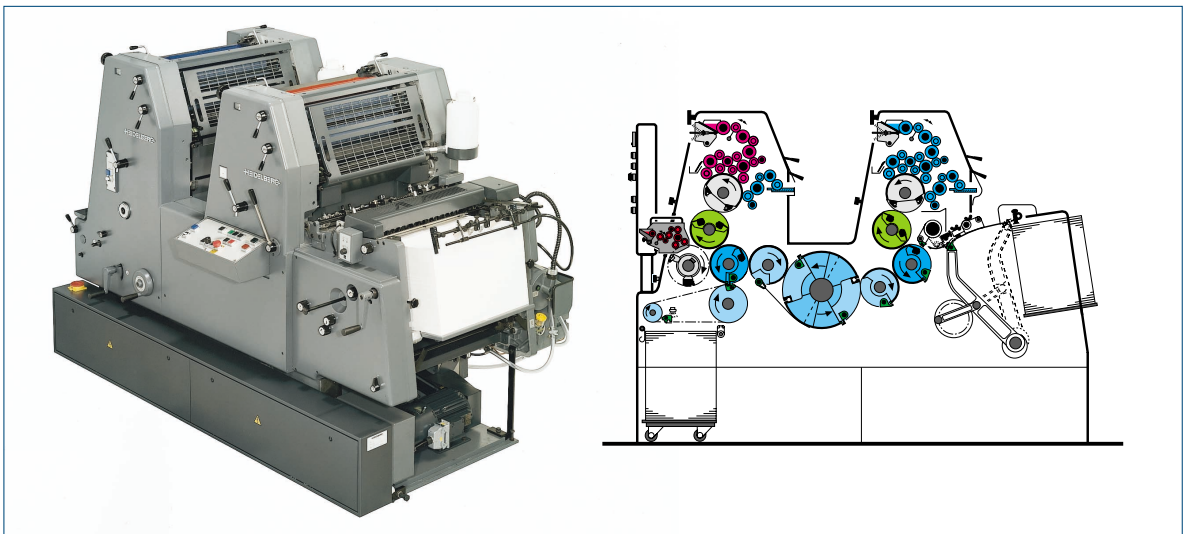
“Hybrid presses”, which combine heatset offset printing with coldset offset printing in one and the same machine, were often installed at the end of the





**Fig. 2.1-183**

Speedmaster SM 52, 4-color press, 2/2 sheet reversal, high-pile delivery; sheet size 370 mm × 520 mm, printing speed 15000 impressions/hour (Heidelberg)



**Fig. 2.1-184**

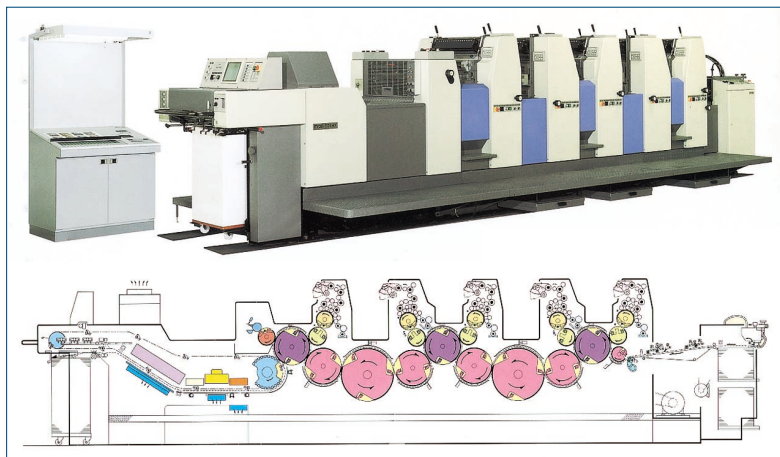
Printmaster GTO 52-2 as a typical small-format offset press with perfecting unit, high-volume inking unit for high-quality printing and ink fountain zones which has to be set manually. 4-color prints in two passes are also possible. Fitted with numbering device; sheet size 340 mm × 505 mm, printing speed 8000 impressions/hour (Heidelberg)

**Fig. 2.1-185**

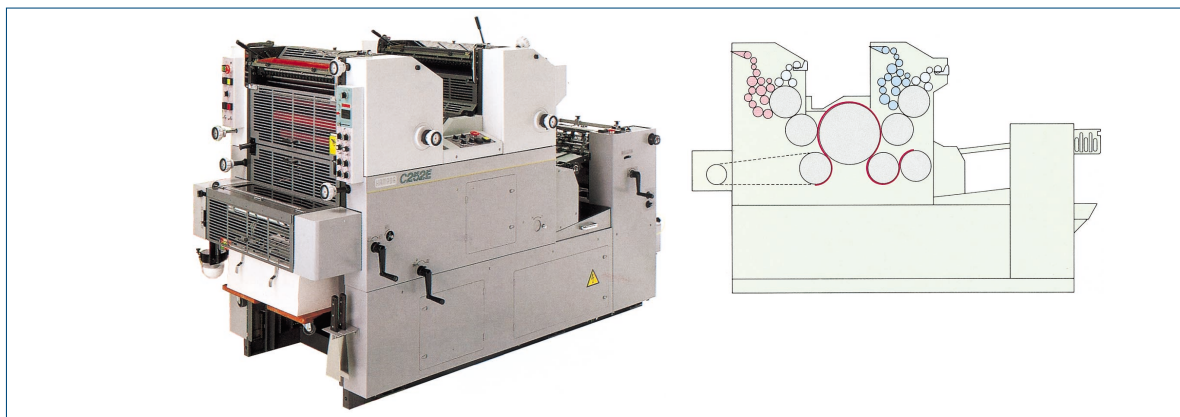
Sprint GS 226P, compact 2-color press with sheet reversal. Control console integrated into delivery; sheet size 480 mm × 660 mm, printing speed 12000/10000 impressions/hour, reduced speed for perfecting (Komori)

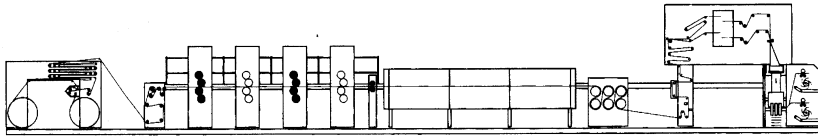
**Fig. 2.1-186**

Ryobi 525, 5-color press with coating unit and high-pile delivery, 5-cylinder system; sheet size 520 mm × 375 mm, printing speed 13000 impressions/hour (Ryobi)

**Fig. 2.1-187**

Hamada C 252, 2-color press based on the 5-cylinder system; sheet size 520 mm × 365 mm, printing speed 10000 impressions/hour (Hamada)

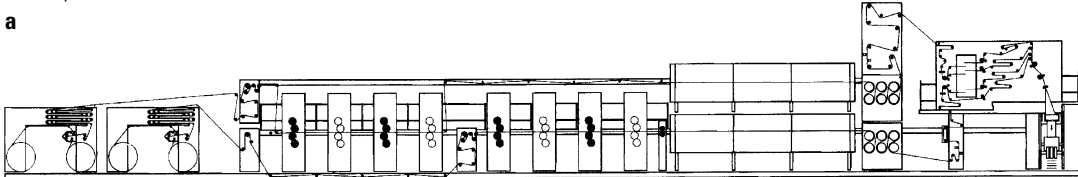




Single web offset printing system with four blanket-to-blanket units.

The press is equipped with a zero speed web splicer with horizontal festoon, hot-air dryer, cooling system and folder with dual delivery.

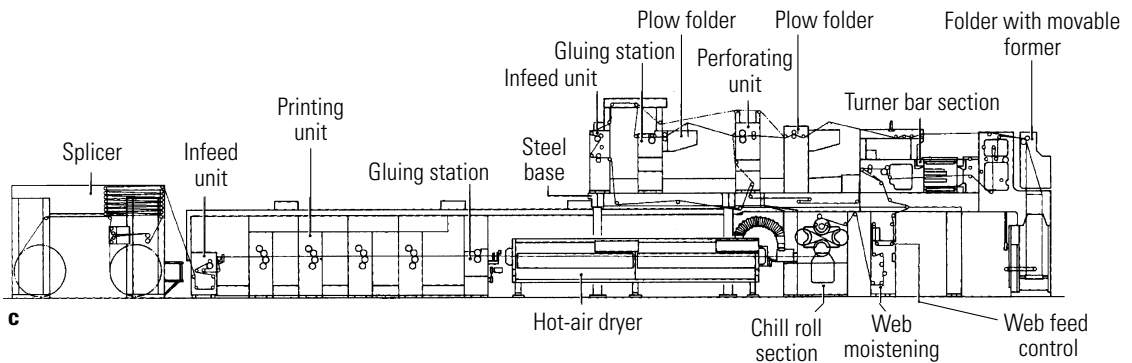
**a**



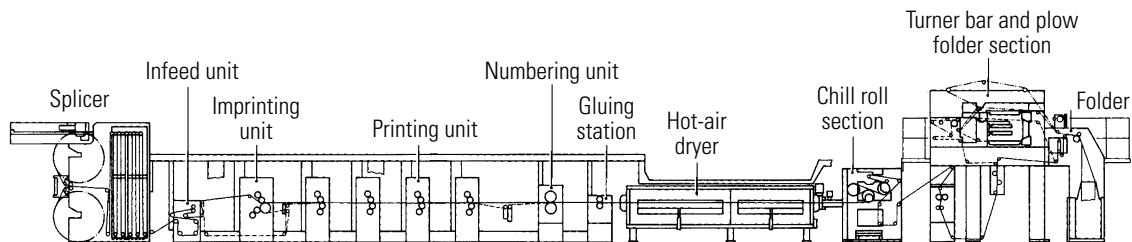
Two-web offset printing system with 2 x 4 blanket-to-blanket printing units.

The installation is equipped with two zero speed web splicers and horizontal festoons, two heatset dryers, cooling system and folder.

**b**



**c**



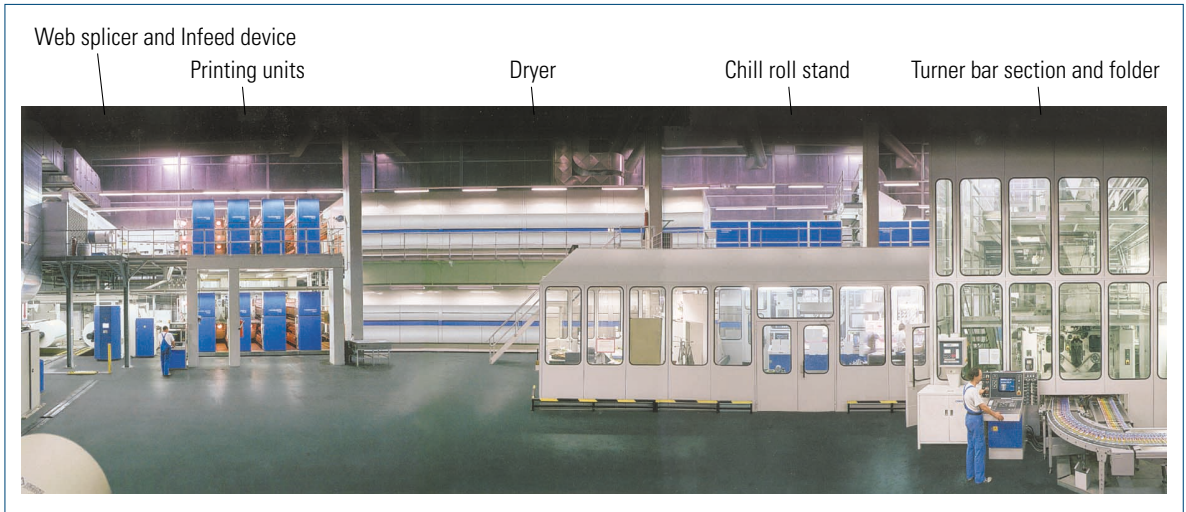
**d**

Remark: Examples (c and d) of web offset printing presses for publication printing fitted with very different peripheral equipment for finishing the printed web.

**Fig. 2.1-188** Commercial web-fed offset printing systems ([2.1-7])

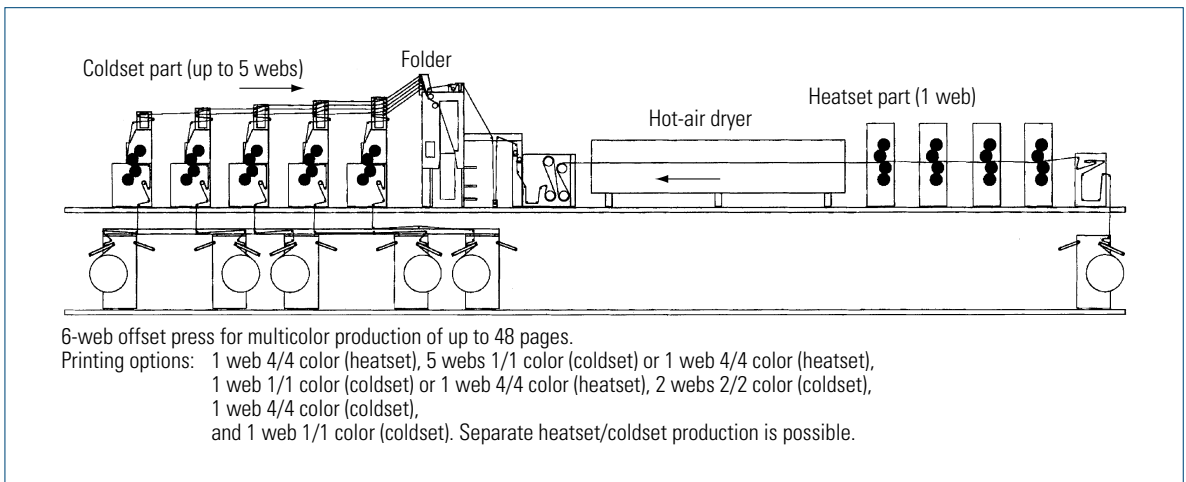
1970s and the beginning of the 1980s. They facilitate economically produced printed products in that only part of the total product is produced on relatively expensive coated paper with heatset inks (cured by heat), which are also expensive, while the other part, more often than not the inside part of the product, can be printed on more favorably priced standard newsprint

without the use of dryers. An example of this can be seen in [figure 2.1-190](#), where the coldset part is on the left and the heatset part with the hot-air dryer on the right. In the middle is the folder with its superstructure, into which all six webs are fed for the combined product to be produced. The six reel stands are in the basement.



**Fig. 2.1-189**

Two-storey commercial web offset press for two-web operation; M-3000 Sunday Press with max. web speed of 15 m/s, 48 pages and PFF-3 folder (Heidelberg)



**Fig. 2.1-190** Example of a hybrid printing system for heatset and coldset web offset ([2.1-7])

Figure 2.1-191 shows that lengthy heatset dryers (hot-air nozzle dryers) can also be stacked on top of typical double-width *newspaper web offset presses*. The dryer has been placed above the printing units and folder superstructure so that the length of the web-fed press installation is not prolonged unnecessarily (as the printing system shown in [fig. 2.1-190](#)). The *four-high unit* between the left folder and the heatset dryer in this case proves to be a series of four blanket-to-blanket printing units rotated in a vertical direction to produce 4/4 prints, before the web enters the heatset dryer. Since there is also a folder on the right-hand side, the system can be divided, so that in addition to the hybrid operation already described, heatset and coldset products can be produced separately with this equipment.

Considerably shorter structured *infrared (IR) dryers* are used in newspaper web presses for semi-commercial printing instead of the relatively long-structured *hot-air dryers*. They do not offer the same quality as heatset dryers. They do not vaporize solvent or give the ink the desired gloss, but they tend to support the absorption of inks and to achieve higher density values. As can be seen in [figure 2.1-192](#), they are located above and need considerably less space, which is why several dryers can be used for several webs.

That there are also single-width and considerably more simply constructed newspaper presses in addition to the double-width newspaper rotaries is clearly shown by [figure 2.1-193](#). In this example even the reel stands are integrated in the printing units, in order to save space. The three printing units are designed as *Y-type printing units* and thus allow 2/1 printing on each of the three webs. Combined printing by two printing units is shown on the left of the illustration, and this allows 4/2 printing on one web, while 2/1 printing occurs on the second web. A sixteen-page full format (broadsheet) or a thirty-two-page tabloid newspaper is produced in the folder in this way. A quarter of its pages can be in four colors and half in two colors, only a quarter is in a single color. This produces a thoroughly respectable newspaper, in spite of the relatively small size of the installation.

One way to increase the number of pages is to link together two *parallel installations* by means of turner bars, which is shown in [figure 2.1-194](#). (In the illustration the two installations are actually shown standing one underneath the other, but they must be imagined as standing next to each other.) Once again the system

produces with single-width printing units, the webs of which are led into one of the two folders on the far outside right via the turner bars on the right. One installation (lower) is equipped with a compact hot-air/infrared dryer, so that hybrid-mode production can also take place.

[Figure 2.1-195](#) shows that the units can be *stacked*. Steel frames support the upper printing units and connect them with the lower ones. The folder is arranged in the middle, and the reel stands/splicers are partly built into the printing units. An example of an installation in which two commercial web offset presses are configured one above the other has already been shown in [figure 2.1-189](#).

[Figure 2.1-196](#) shows a web-fed newspaper printing system suitable for a confined space. The two four-high printing units (on the left) are *very compact* in structure thanks to the design with lateral extraction of the inking units and have been installed in the basement, while the three reel stands take their place next to them on the right. The folder, too, has been installed in the basement, so that the folder's superstructure would not stand higher than the printing units.

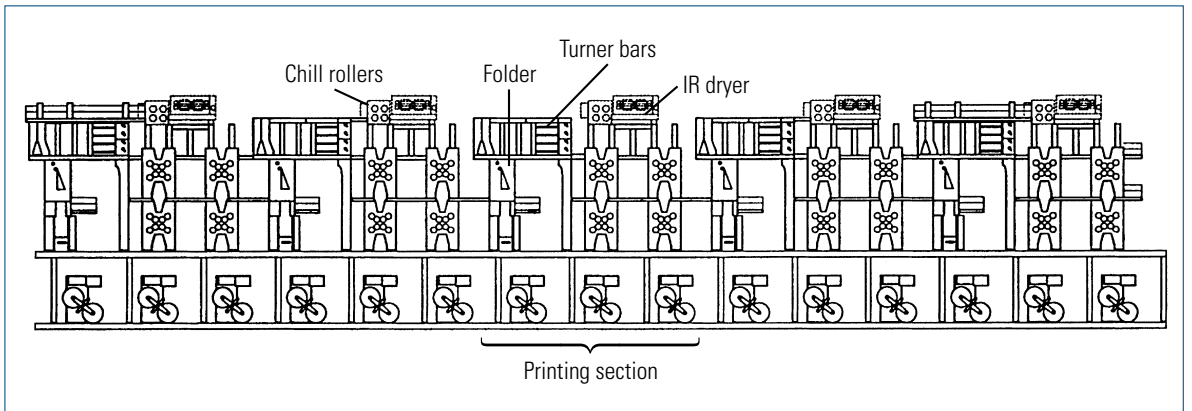
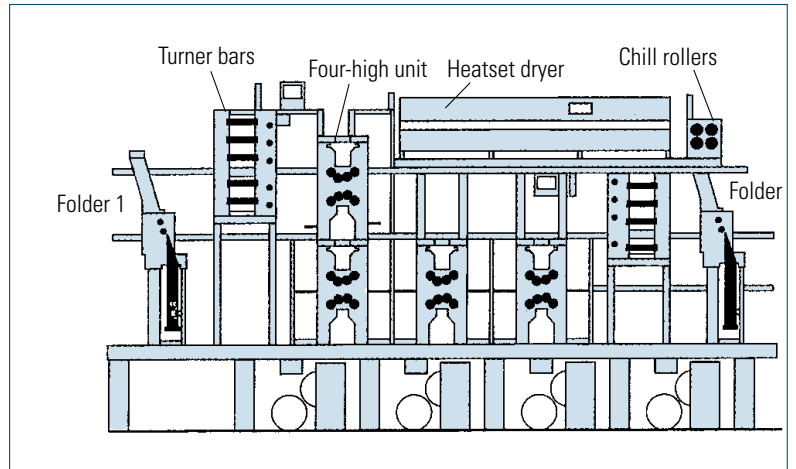
A typical *single-level installation* with three Y-type printing units is shown in [figure 2.1-197](#). In this installation all units of the press are at the same level. Since the webs must, to a certain extent, be drawn through under the printing units, the units stand slightly raised on pits. Thus a gallery for running the installation is only required on the folder superstructure. The flight of stairs included in the drawing makes this clear.

[Figure 2.1-198](#) shows a typical *four-high, web-fed press installation*. It is standing on a concrete substructure with reel stands underneath. Densely packed turner bars or folder superstructures are fitted above the four folders and the planned expansion with an infrared dryer is indicated by the broken lines. The "skip slitter" (intermittent web slitter) on the roller top of former (RTF) for printing tabloid-in-broadsheet products (see also [fig. 2.1-113](#)) can also be seen. The four-high units are formed from *H-type printing units* stacked on top of each other, which in turn consist of an *arch-type printing unit* and a U-type printing unit standing above it.

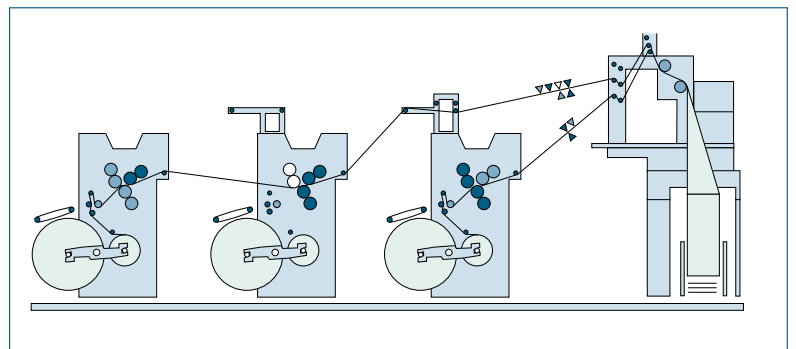
It becomes clear in [figure 2.1-199](#) that besides the four-high units consisting of *stacked H-type printing units* there are also configurations that comprise only stacked arch-type printing units; in this case an installation with anilox inking system (see [fig. 2.1-122](#)).

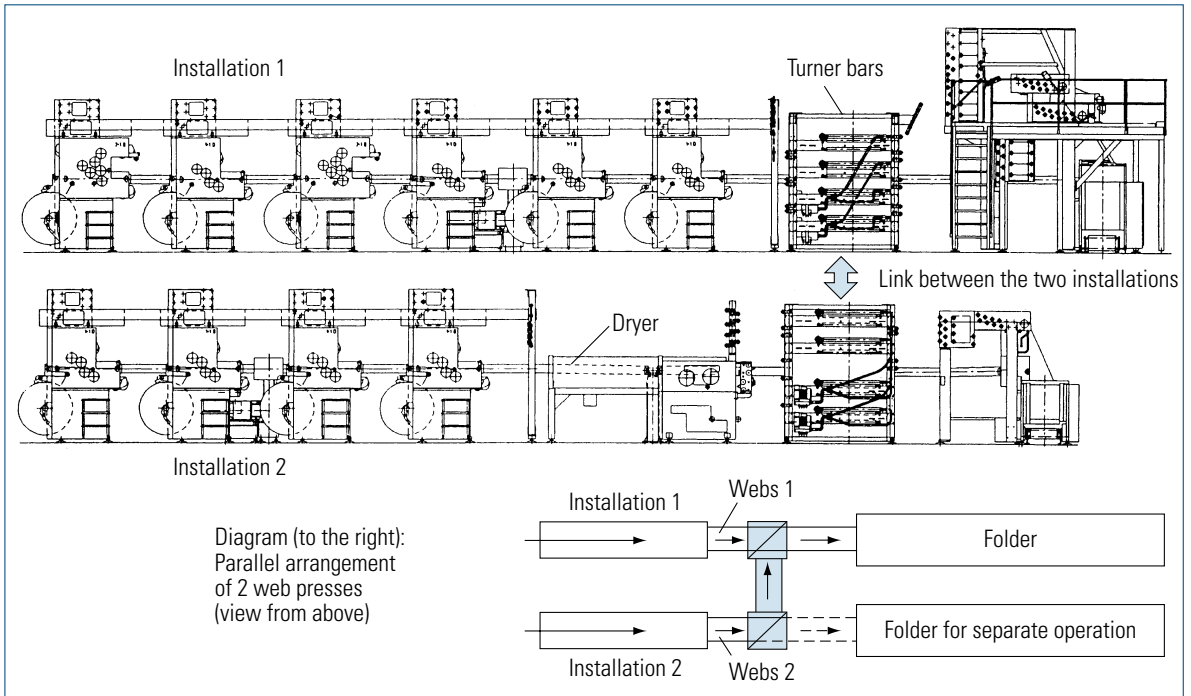
**Fig. 2.1-191**

Newspaper press with a heatset dryer above it (IFRA/KBA)

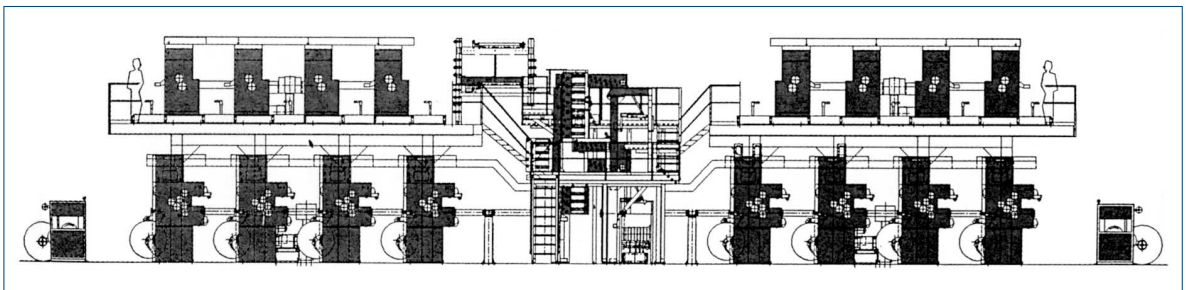
**Fig. 2.1-192** Long web-fed printing system for newspaper printing with infrared (IR) dryer above it (IFRA/MAN Roland)**Fig. 2.1-193**

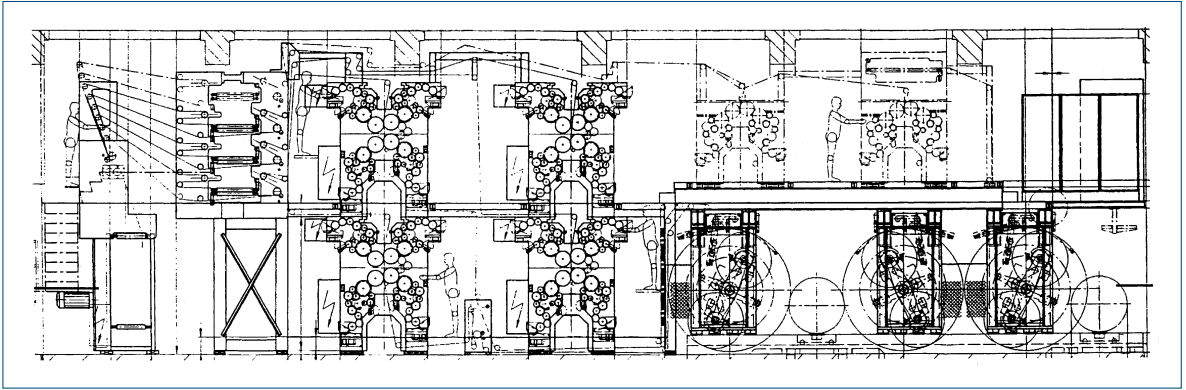
Simple newspaper press with Y-type printing units (IFRA/MAN Roland)



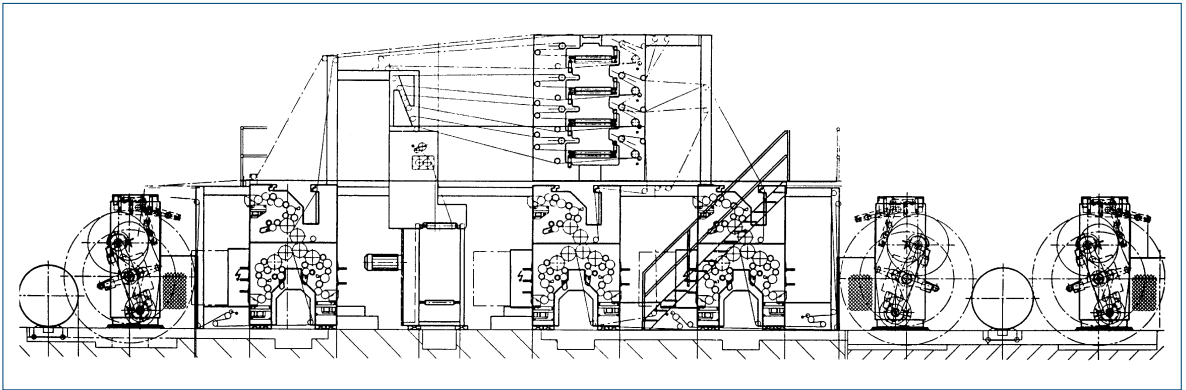
**Fig. 2.1-194**

Parallel configuration (next to one another) of two production systems for newspaper printing and transfer of the webs by means of turner bars (IFRA/Solna)

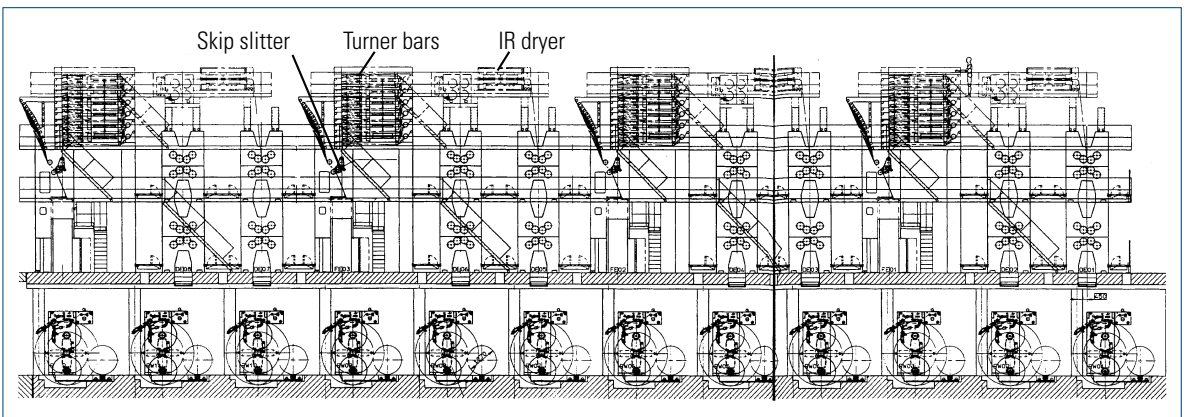
**Fig. 2.1-195** Vertical configuration of printing systems above one another for multi-web newspaper printing (IFRA/Solna)



**Fig. 2.1-196** Four-high units (compact design) and arch-type printing units in newspaper printing (IFRA/KBA)

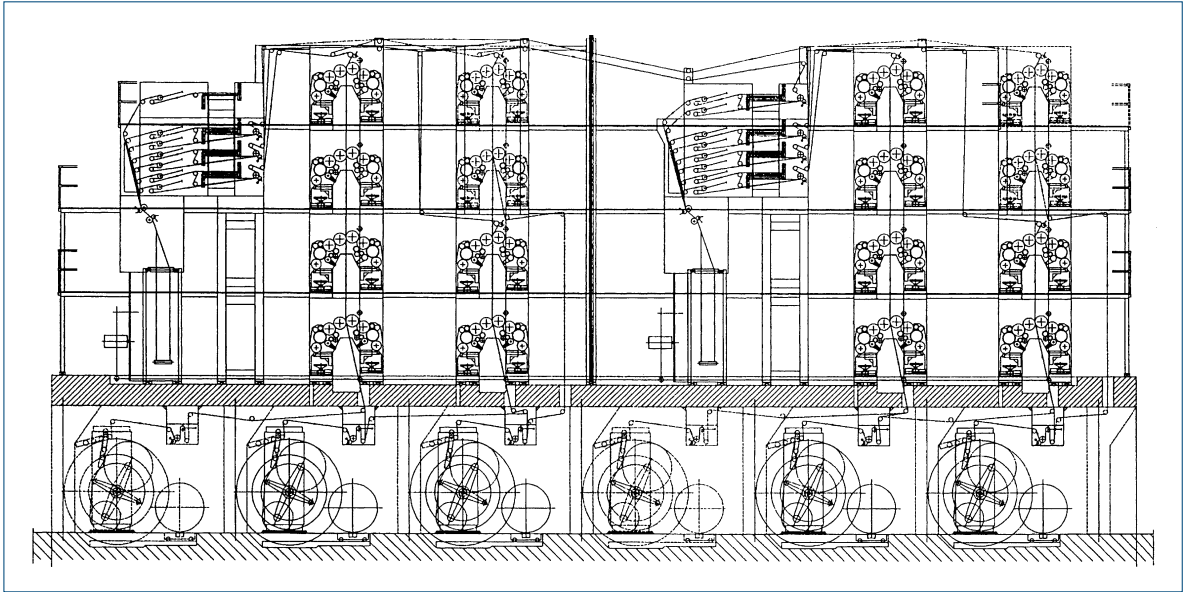


**Fig. 2.1-197** Single-level design of a web printing system with Y-type printing units for newspaper printing (IFRA/MAN Roland)



**Fig. 2.1-198** Long web-fed printing installation with four-high units made up of H-type printing unit (IFRA/MAN Roland)





**Fig. 2.1-199** Web-fed printing system with four-high units in the form of stacked arch-type printing units (IFRA/KBA)

The drawing clearly illustrates that the same geometrical ratios exist on all stories, which can be an advantage from the operational point of view. Each story can be reached via its own operating gallery. The folders are on the left and in the middle, the reel stands in the basement.

The peculiarity of the installation shown in [figure 2.1-200](#) lies in the fact that it is assembled using both four-high units and *ten-cylinder satellite printing units*. The four-high units on the left have even been extended to form *six-high units*, by further H-type printing units being placed on top of the four-high units. An infrared dryer is located above the ten-cylinder satellite printing units. The upper parts of the ten-cylinder satellites involve typical “color decks”, originating from the time when only spot colors were printed on newspapers (instead of the present-day four-color printing).

The same principle can also be applied with *nine-cylinder satellites*, as shown in [figure 2.1-201](#). The press stands on a steel substructure, and the reel stands are housed between its props. The upper parts of the printing units function again as color decks (see also [sec. 2.1.3.5](#)), each printing couple (plate and blanket

cylinder) having its own impression cylinder and consequently offering great versatility of use. There are also color decks in which two printing couples are engaged in a V-shape with one common impression cylinder.

In [figure 2.1-202](#) it is demonstrated that the long *hot-air dryers* can also be installed vertically between the printing units.

The many very different examples of printing systems make it clear that in the construction of *web-fed printing systems* (and in particular for newspaper printing) one installation scarcely resembles another. Even if the same units of machinery are used, their assembly differs from customer to customer according to the different product ranges, the different space ratios and not least the individual preferences of the publisher and the printing company’s manager.

A succession of illustrations shows a selection of *installations in printing companies* for production plants with web offset printing systems. The first examples are concerned with the production of *commercial print jobs* ([figs. 2.1-203 to 2.1-207](#)); the examples shown in [figures 2.1-208 to 2.1-212](#) are installations for the production of *newspapers*.

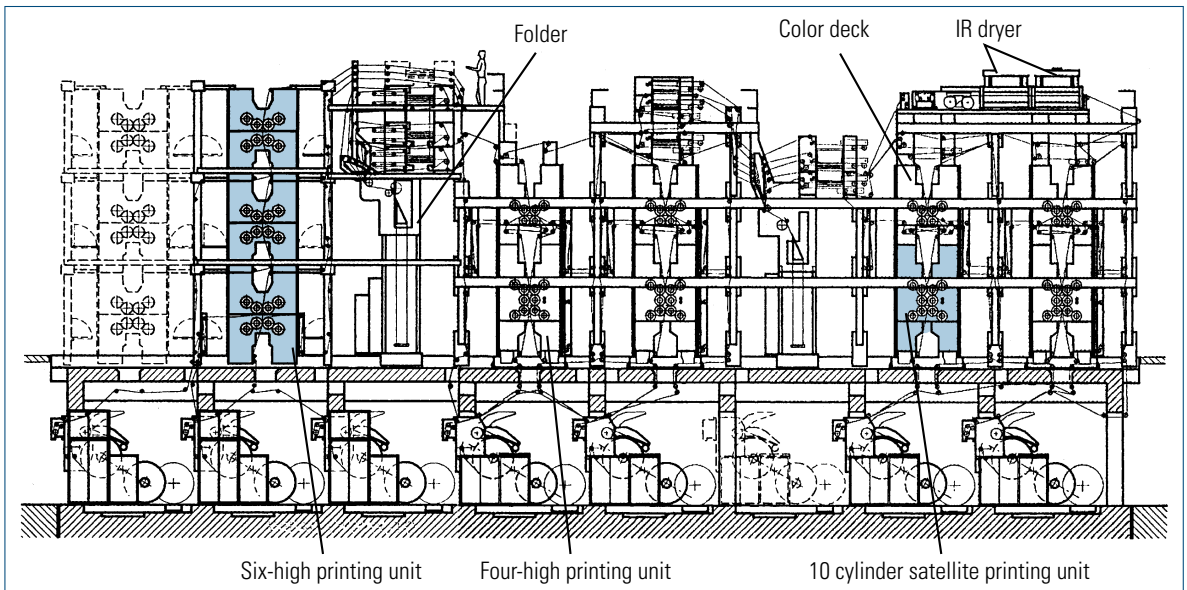


Fig. 2.1-200

Web printing system combining 10-cylinder satellites, color decks and four-high units, extended to form six-high units (IFRA/WIFAG)

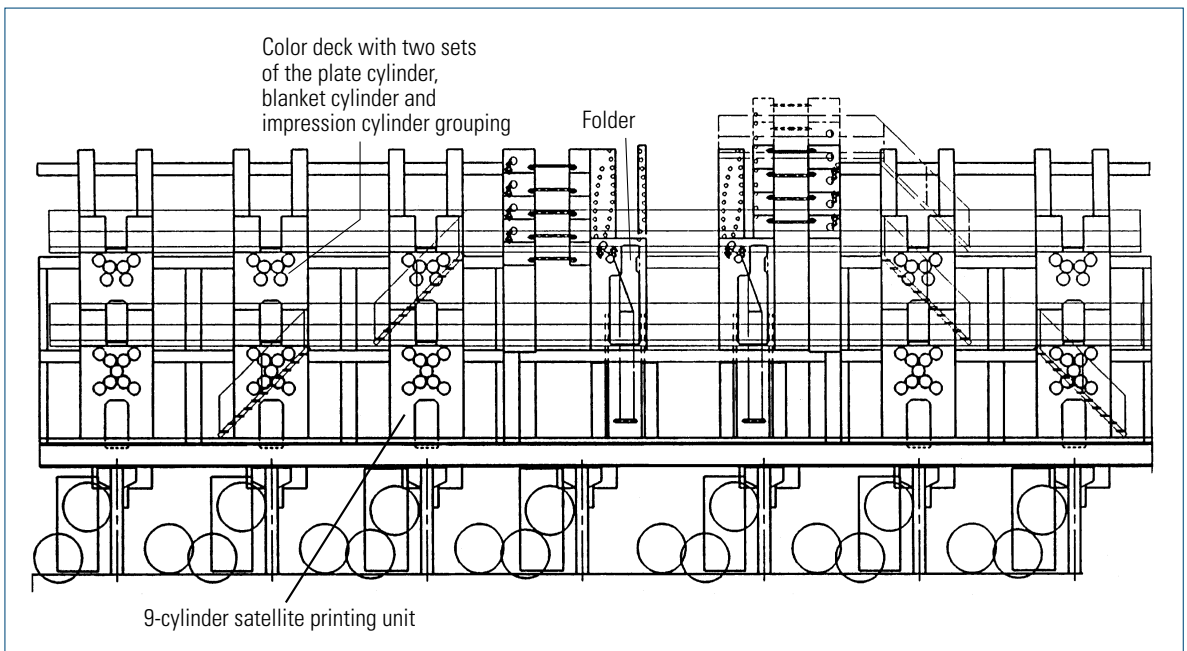
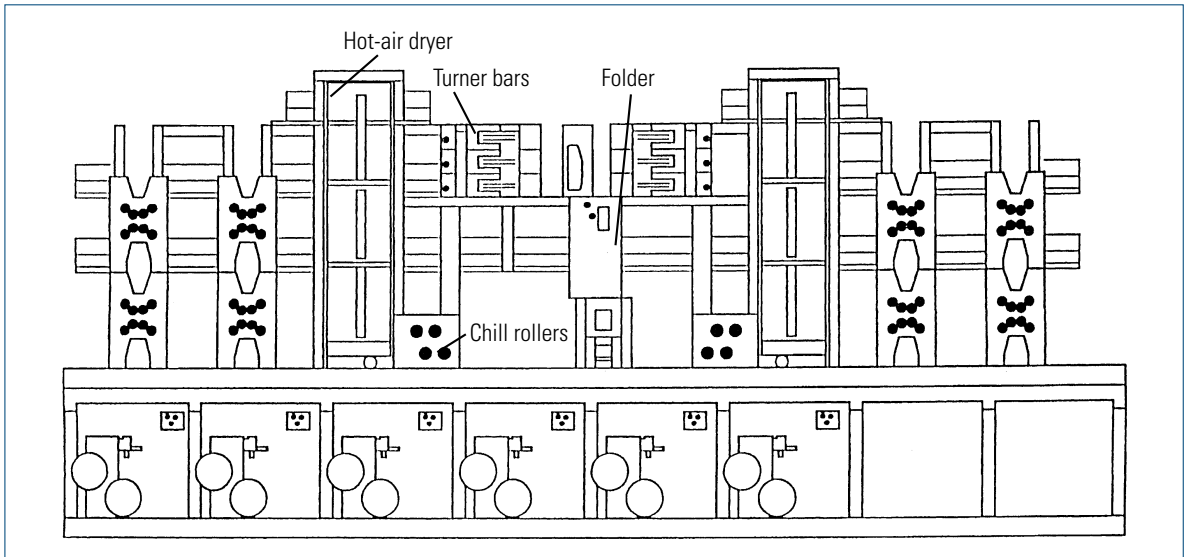


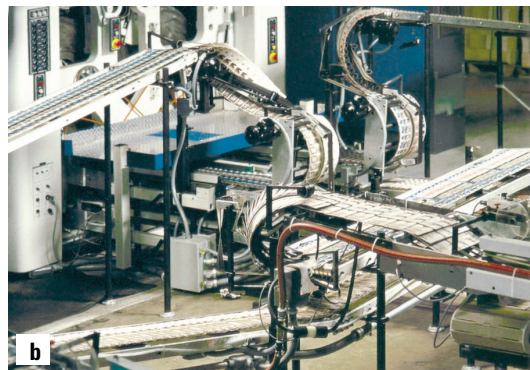
Fig. 2.1-201 Web printing press consisting of 9-cylinder satellites with attached color decks (IFRA/MAN Roland)

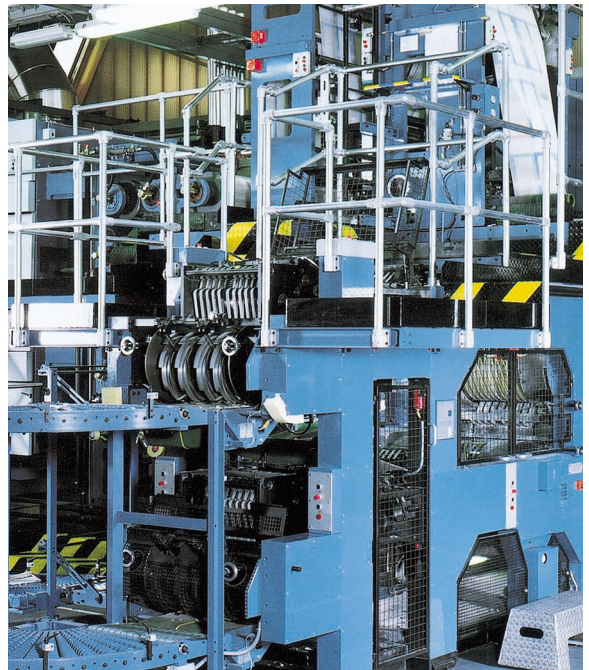
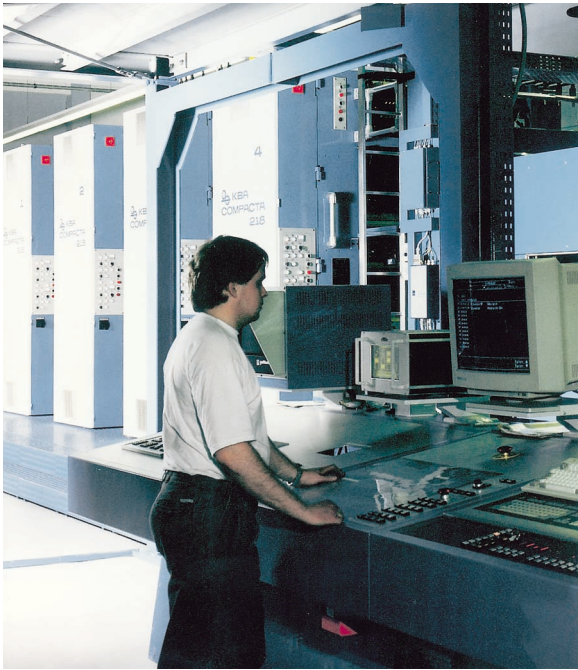


**Fig. 2.1-202** Example of a web printing system with vertically configured hot-air dryers (IFRA/MAN Roland)



**Fig. 2.1-203**  
**a** Commercial web offset printing system (48 pages, double-sized cylinders, 50000 revs./hour, max. 100000 copies/hour, web speed 15 m/s) with zero-speed web splicer in horizontal design (M-4000, Heidelberg);  
**b** Folder with double stream delivery, copy stream diverters and gathering (PFF-3, Heidelberg)



**Fig. 2.1-204**

Web offset printing press (16 pages, max. 80000 copies/hour) with central control console and modular folder with two deliveries (Compacta 218/folder P3, KBA)

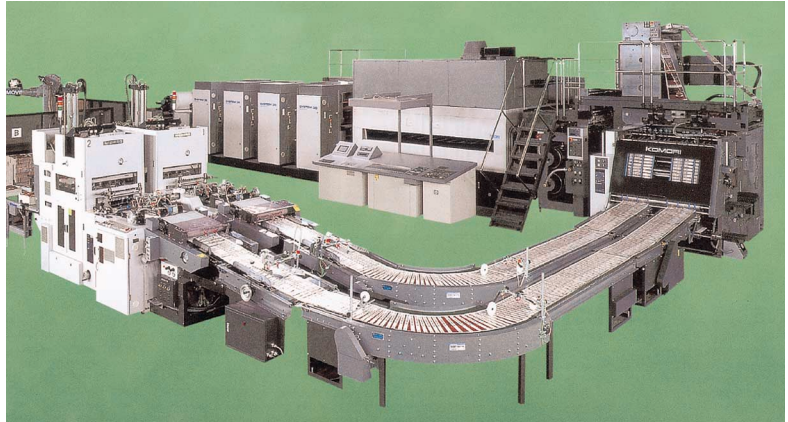
**Fig. 2.1-205**

Web offset press (16 pages, up to 60000 copies/hour) with control consoles for remote control, color register control and web inspection (Lithoman III, MAN Roland)

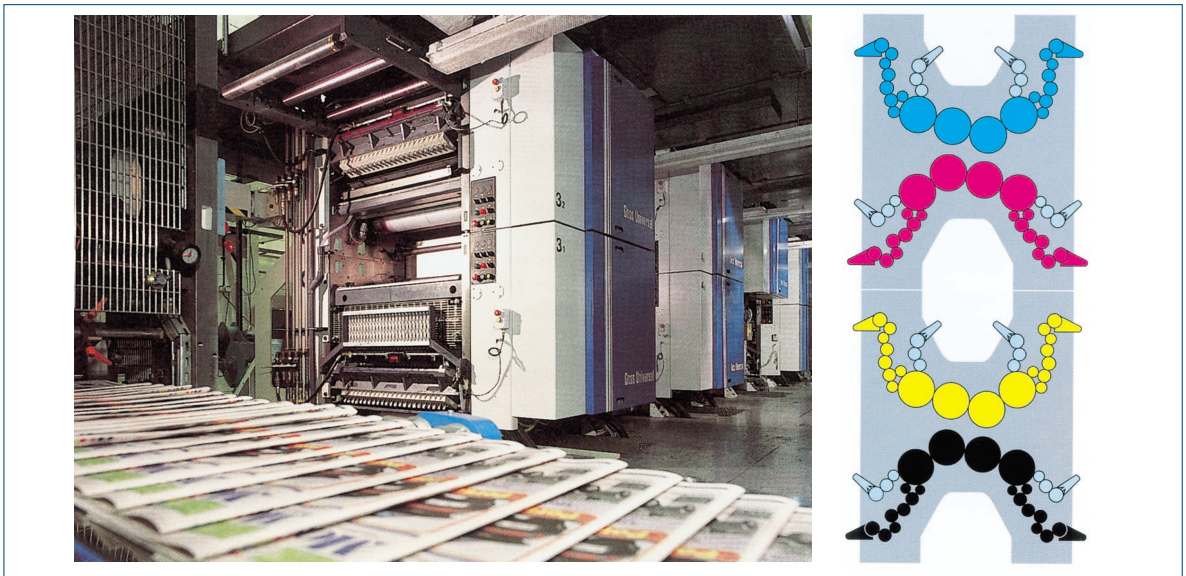


**Fig. 2.1-206**

Web offset printing system (16 pages, max. web width 880 mm, cut-off 546 mm, max. 48000 copies/hour) with double delivery and packaging unit (System 35, Komori)

**Fig. 2.1-207**

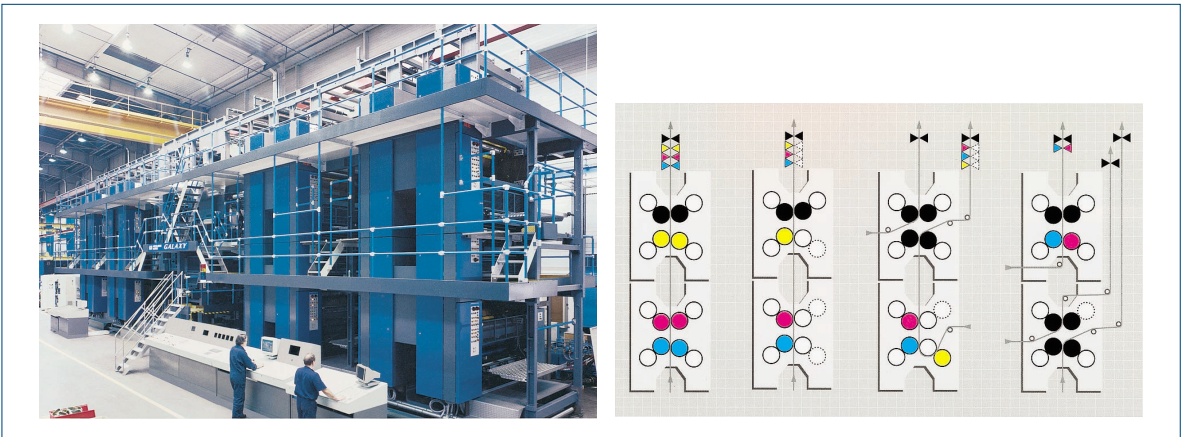
Web offset printing press (max. web width 880 mm, cut-off 546 mm, max. 48000 copies/hour) with reel splicer in swing-arm design (Lithopia BT2-800, Mitsubishi)

**Fig. 2.1-208**

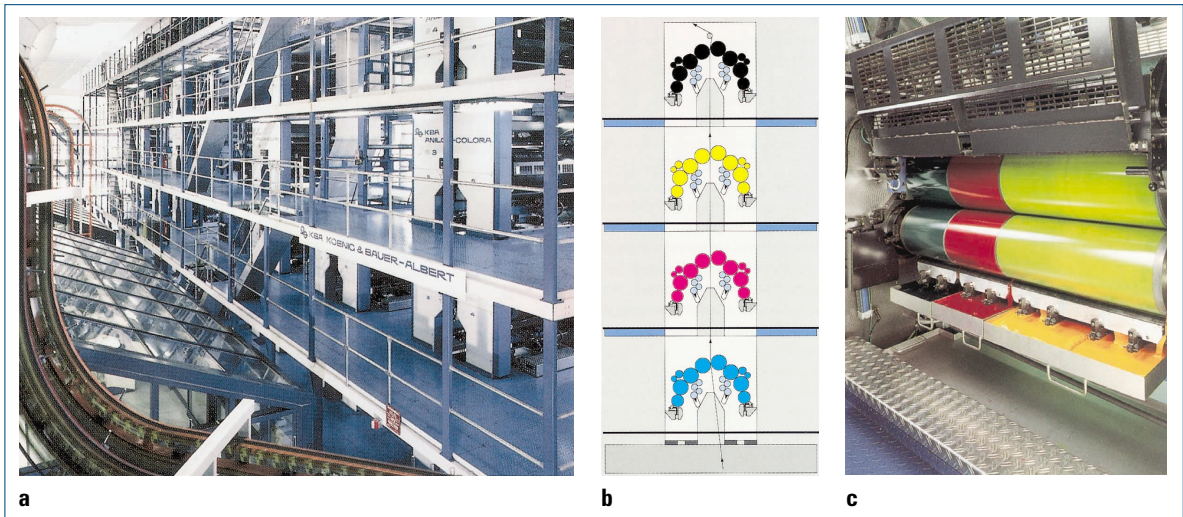
Web offset printing press for newspaper printing (max. web width 914 mm, cut-off 600 mm, max. 70000 copies/hour) with printing units consisting of H-type units; four-high unit constructed with two H-type units (Universal 70, GOSS)

**Fig. 2.1-209**

Examples of installations of a web offset newspaper printing system (Model line for max. web width of 1020 mm, cut-off max. 630 mm; for coldset max. 45000 copies/hour, for heatset max. 35000 copies/hour) (Mercury, Heidelberg)

**Fig. 2.1-210**

Web offset newspaper printing system (16 pages, double-sized cylinders, max. 35000 revs./hour, max. 70000 copies/hour) with variants for web feeding and color arrangement in the four-high units (Galaxy, Heidelberg)

**Fig. 2.1-211**

Web offset newspaper printing system with Anilox short inking units (web width max. 1680 mm, cut-off max. 578 mm, double-sized cylinder, max. 70000 copies/hour in double production).

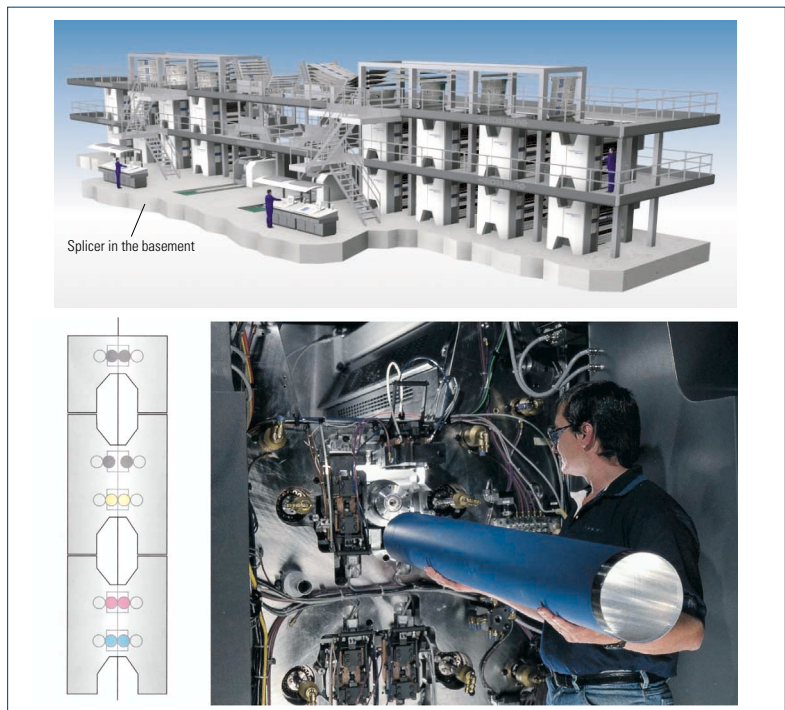
**a** Newspaper printing system;

**b** Four-high unit constructed of four arch-type printing units with Anilox short inking unit;

**c** Anilox offset short inking unit with quarter and half width ink fountains for printing different colors page-by-page across the total web width with the same printing unit (Anilox-Colora, KBA)

**Fig. 2.1-212**

High-speed web offset newspaper printing system (8 pages per blanket-to-blanket printing unit, 80000 copies/hour) with four-high units consisting of two H-type printing units and the option of integrating an arch-type unit for on-the-run change of the printing plate for black (e.g., for different versions within a print run), gapless blanket cylinder and multi-motor drive. Configuration (figure at top) with eight 4-high units for a 64-page production. Web splicers are installed in the basement (Mainstream 80, Heidelberg)



## 2.1.7 Potential for Further Development

The offset process has long been the leading print technology for economical production for high-quality medium and long print runs. The success of offset printing since around 1960 has been such that the image carriers used for this lithographic printing can be produced very cost-effectively offering high-quality reproduction and long service lives, at relatively low costs, under standardized conditions, and in an environmentally sound manner. Furthermore, production processes and system components for offset printing have been developed to provide for fast makeready and stable production conditions. The printing systems are operated via user-friendly interfaces. Digitization supports and simplifies procedures and makes them more reliable throughout the entire printing process. In particular, with regard to operating the printing press, the printer is no longer an expert on performing manual tasks, but is increasingly taking on the role of a data manager. Sophisticated equipment, materials, and production technologies are available, and the supplier industry uses an efficient component and material coordination network based on generalized standards.

Despite the achievement of an already very high technological level there is obvious further potential to optimize print media production based on offset printing technology.

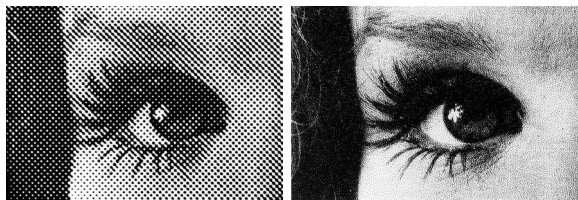
This applies especially to the following topics:

- improvement and stabilization of print quality;
- improvement of offset processes through new methods and provision of innovative materials;
- shortening of makeready times and reduction of waste.

### 2.1.7.1 Print Quality

#### Frequency-Modulated (FM) Screening

Through digitization in prepress it is possible to use frequency-modulated screening more widely (see [sec. 1.4.3](#)). This screening process makes it possible to reproduce finer structures in the printed image ([fig. 2.1-213](#)) and, additionally, to eliminate disturbing effects such as moiré and rosette patterns (see [figs. 1.4-28](#) and [1.4-31](#)), connected with the periodic structure of an amplitude-modulated screen. Moreover, frequency-modulated screening of color separations makes multicolored images less susceptible to color variations caused by register deviations.



**Fig. 2.1-213**

Frequency-modulated screening (on the right) compared to conventional, amplitude-modulated screening (on the left)

This implies that there is potential for increasing the reproducible quality in the print through the use of available technologies. The insensitivity of the stochastic screen to color register deviations enables the printer to attain the desired production conditions faster; also during production the multicolored image reacts less sensitively towards color register deviations, which can occur as a result of variations in paper quality in the pile, climatic influences on the press or ink, or dampening solution effects.

These facts alone indicate that frequency modulation will be widely used and holds potential for improving production. Prepress and press technology and equipment are prepared for this.

#### High-Fidelity Colors (HiFi Colors)

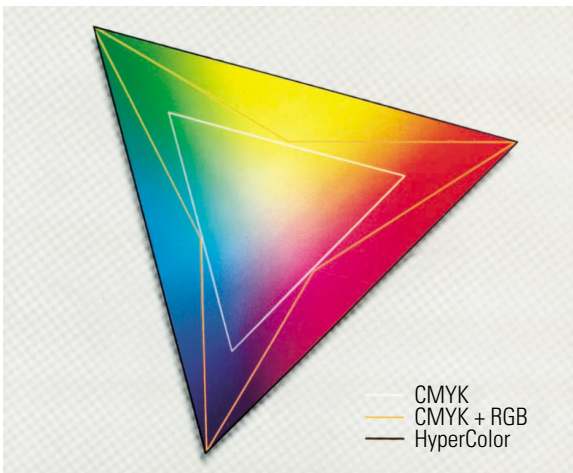
For special printing applications that demand the highest reproduction quality, fine screens with the highest resolution are used, and in order to reproduce a large color space ([fig. 2.1-214](#)) more than four colors are printed. In addition to the process colors cyan, magenta, yellow, and black, the complementary colors blue, green, and red are used in seven-color printing. This leads to a much greater reproducible color gamut and, with it, more intensive coloring, as well as to greater variation of color shades. Therefore, the qualitative gap in quality color reproduction on an efficient color monitor or on high-quality photographic paper for color photographs is somewhat closed.

Employing high-fidelity color systems, the provision of the corresponding inks by the ink industry, as well as optimized color separation technologies, broaden the area of application of offset printing processes. This is reinforced through the increasing use of sheet-fed offset presses with eight and ten printing units, not only for four-color printing on both sides, but also for halftone printing with colors for high-fidelity (HiFi)





**Fig. 2.1-214**  
Color space for specification of visually perceptible color gamut



**Fig. 2.1-215**  
High-fidelity multicolor printing (HiFi color) to expand color gamut in offset printing; diagrammatic (HiFi color system: HyperColor, DuPont)

printing (fig. 2.1-215 also includes a special color set/Hi-Fi color system).

### 2.1.7.2 Offset Printing Process

#### Waterless Offset Printing

Waterless offset printing (also known as “dry offset”) has existed since about 1980. The combination of certain printing plate coating materials with adapted printing inks and inking units made offset printing possible without it being necessary to dampen the printing plate. In principle this technology is to be embraced; after all, customers assess visible print quality purely by the quality of color application. Ink is the only thing visible on the product, and additional materials such as dampening solution used in conventional offset printing are merely an aid to maintaining the printing process. When the operator can concentrate solely on ink application/color quality, without having to think about applying dampening solution, press operations become easier and safer, and as a result the entire process is more straightforward. Waterless offset printing is, therefore, from the user’s point of view, a desirable print technology, which can make the workplace more interesting and the processes simpler.

The fact that waterless offset is not yet more widespread (optimistic estimates calculate the proportion of print media produced in offset using the dry offset method to be in the region of 5%) is largely due to the following factors:

- The printing plates are markedly more expensive than the established, conventional plates; however, change is underway here, since the years of monopoly by one company are over, and a number of large printing plate manufacturers have voted in favor of waterless offset, which will eventually bring costs in line with those for conventional printing plates.
- A further drawback to waterless offset printing is the fact that inks with a different viscosity (greater tack) are used, which places greater demands on the paper surface during printing, so that paper with less stable coating or portions of fiber and paper dust can lead to more rapid dirtying or deposits collecting on the blanket (the automatic cleaning effect of dampening solution found in conventional offset is not present); this results in deficient print quality and means that the press has to be stopped for cleaning.

The fact that the waterless offset process requires a printing unit temperature control within relatively narrow tolerances as compared to traditional offset printing is no obstacle to it becoming more widely used. Today's presses are either fitted with an inking unit temperature control as standard, or else they are available as optional extras (fig. 2.1-216).

- The surfaces of waterless offset printing plates are generally more susceptible to mechanical damage and wear and tear; this calls for more careful handling within the entire process. Potential for improvement is available in the form of materials/coatings. One can assume that these new materials will soon be available for practical use.

It is predicted that, in the coming years, waterless offset will become more widely accepted and that printing companies will concentrate more intensively on the use of this technology.

### Direct Imaging and Re-imageable Printing Plates

In conjunction with digital penetration of prepress, platemaking directly in the offset press has become possible (computer to press/direct imaging, fig. 2.1-217). Thermal ablation plates, which are imaged for a specific job with thermal laser light directly on the plate cylinder, are available for waterless and conventional offset alike (see also sec. 4.4).

One technological challenge is the development of printing plate materials or preparation processes that make it possible to re-use for the next print job the printing plate that was imaged and used for the previ-

ous job; that is, to achieve the innovation of being able to erase and re-image the image carrier/plate surface (see sec. 4.4.2). This could on the one hand reduce preparation times (no changing around of plates) and on the other lead to better quality results and lower costs.

### 2.1.7.3 Drying

One problem with offset printing is that the ink is usually not sufficiently dry after printing, and therefore direct further processing/finishing of printed sheets is not possible.

In offset printing a sufficiently dry sheet that can be further processed is only achieved through special additional drying units integral to the machine (see also secs. 1.7 and 2.1.2.6). Hot-air and infrared drying are state-of-the-art; in particular, UV drying, in conjunction with special inks, makes it possible for the sheet to be dry when it arrives in the delivery or to be directly further-processed in line. For process reasons web offset presses are equipped with hot-air dryers for in-line drying, since finishing operations such as cutting, folding and so on, come directly after printing. The dryer is accepted as state of the art here and is justifiable with regard to production costs. But, of course, here, too, it would be desirable if one could do without these space-consuming units.

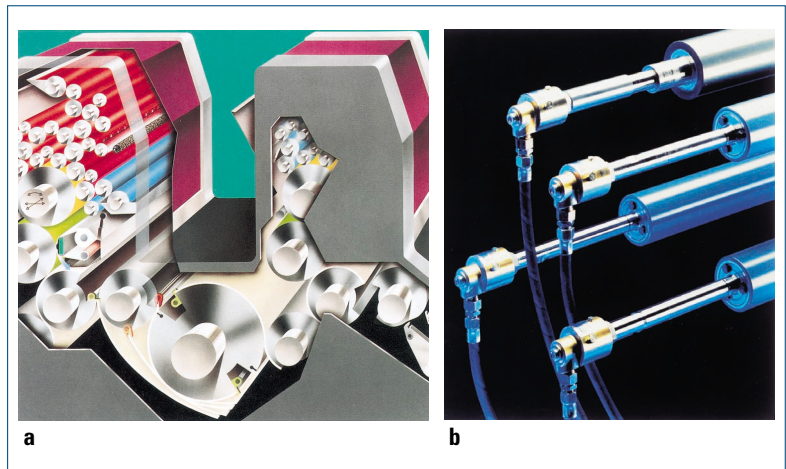
In sheet-fed offset insufficient drying is often compensated for by the application of powder in the delivery section so that undesirable quality-reducing ink setoff in the pile is prevented, and furthermore rather quicker finishing is possible (see sec. 1.7.3.1). Powdering is an additional operation bound up with costs,

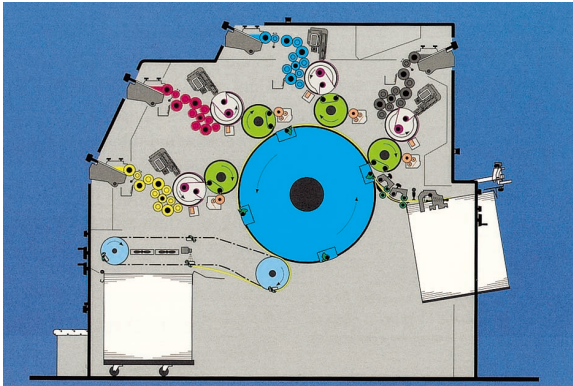
**Fig. 2.1-216**

Inking unit temperature control in printing units for waterless offset (dampening unit can be switched off/left off).

**a** Printing unit;

**b** Rollers in the inking unit (distributor rollers and ink fountain roller), connected to the temperature control cycle (Heidelberg)





**Fig. 2.1-217**  
Computer to press/direct imaging printing system  
(QM DI 46-4, Heidelberg)

and it leads to certain areas of the press getting dirty, and therefore to extra cleaning work and possibly also quality-reducing effects (e.g., in print jobs with coating, or through the generally gloss-reducing effect of fine powder particles).

A particular challenge facing ink manufacturers is the development of new ink systems to bring about speedier drying. A number of proposals are under discussion, for example the development of water-based, quick-drying offset inks. The development of new drying equipment and drying processes is likewise just as great a challenge for the supply industry as it is for printing press manufacturers.

#### 2.1.7.4 Automation

Automation using remote control and measurement and control technology in carrying out the makeready in printing systems and in monitoring the print run is of a very high level (fig. 2.1-218 and secs. 2.1.4 and 2.1.5). Nevertheless, there is potential for further development aimed at further reducing makeready times and waste.

#### Inking Units

Among the factors we should mention here is the development of quick-reacting inking units with a shorter ink train and quicker uptake of stable production conditions after changes in the ink supply. “Short” inking units, with fewer inking rollers and optimized roller diameters that prevent quality-reducing effects such as ghosting, are at the trial stage; they are in use

in newspaper printing (see figs. 2.1-11, 2.1-122) and could also be interesting for sheet-fed offset printing.

#### Remote Control

“One-person operation” is already a reality even with large presses. The operator can initiate all functions and monitor the entire process from the central control station (fig. 2.1-218, see also sec. 2.1.4.1).

#### Measurement and Control Technology

The further development of in-line measuring technologies is only constrained by cost factors, and there are system designs for in-line color measurement and image inspection (see sec. 2.1.4.5). A challenge for the development of efficient color measurement and control systems is the measurement in the image, that is, measuring print quality without having to print extra measuring elements/patches for color and color register along with the image. Color control strips, which on the one hand involve unnecessary paper trimming/waste, and on the other mean more work in prepress depending on the technology used, would no longer be necessary if measurement technologies and analysis algorithms were developed to acquire the information on print quality and press control directly from the printed image. This is in the interests of the press operator (for quality evaluation purposes), the entrepreneur (because of cost), and the customer (for reasons of cost and quality assurance) alike. The customer is interested in the printed image and not the control elements, which are still today a necessary aid to printing.

#### Job Preparation

Automatic wash-up devices, automatic plate changing, and automatic adjustment of paper guiding elements are in general use. However, there is still potential for improvement in these technologies.

The perfect inking unit and automation system should be of such a design that the first sheet printed is produced in a saleable quality. Today it might still take 100–200 sheets before ink feeding and print quality have stabilized. New inking unit designs and intelligent, adaptive measurement and control software and systems (including color management) are cutting down further on start-up waste.

#### In-line Production

Carrying out more and more print media production tasks in a printing system directly is a goal to work towards for numerous job-specific applications. This is

**Fig. 2.1-218**

Measuring and control system with automation components for a sheet-fed offset press (see also fig. 2.1-150), (Heidelberg)



not only for economic and quality reasons, but also to create innovative printing products. In-line finishing such as cutting and perforating, as well as personalization, binding, folding, and so forth, has a role to play in the development of printing systems.

However, practicability and customer benefit need to be considered most critically – flexible use of printing systems has a high status.

### Environment

There is continual reduction of cleaning processes, above all cutting down on the use of chemicals. Environmental concerns and safety questions are being resolved satisfactorily and beyond mere mandatory restrictions (see also sec. 13.2.1.2).

### References

#### in 2.1.1

- [2.1-1] Handbuch zur Standardisierung des Offsetdruckverfahrens. Bundesverband Druck, Wiesbaden 1989.
- [2.1-2] Pfeiffer, G.: Beitrag zum Problem der Rollvorgänge in Druckmaschinen unter besonderer Berücksichtigung der viskoelastischen Eigenschaften von Walzenbelägen. Diss. TH Darmstadt 1970.
- [2.1-3] Rech, H.: Untersuchung von rückwirkungsfreien Farbauftragungssystemen im Offsetdruck. BVD/FOGRA, Wiesbaden, München 1981.
- [2.1-4] Rech, H.: Möglichkeiten und Grenzen der rechnergestützten Analyse von Offsetfarbwerken. Teil I bis IV. Druck-print 8, 9, 10, 11, 1984.
- [2.1-5] Rech, H.: Beiträge zur experimentellen und rechnerischen Untersuchung des Farbtransportes in Walzen-

farbwerken von Druckmaschinen. Diss. TH Darmstadt 1971.

- [2.1-6] Helbig, T.; Bosse, R.: Grundlagen der Qualitätsbewertung im Offsetdruck. Polygraph-Verlag, Frankfurt/Main 1993.

#### in 2.1.6.2

- [2.1-7] Walenski, W.: Der Rollenoffsetdruck. Fachschriften-Verlag, Fellbach 1995.

### Further Reading

#### for 2.1.1

- Teschner, H.: Offsetdrucktechnik. 10. Aufl. Fachschriften-Verlag, Fellbach 1997.

#### for 2.1.2

- Birkenshaw, J.: Short run printing. PIRA, Leatherhead (UK) 1994.
- Dejidas, L.P.; Destree, T.M.: Sheetfed offset press operating. 2nd. edition. GATF, Sewickley (PA) 1999.
- Destree, T.: The lithographer's manual. GATF, Pittsburgh (PA) 1994.
- Eldred, N.; Scarlett, T.: What the printer should know about ink. 3rd edition. GATF, Pittsburgh (PA) 1995.
- Handbuch zur technischen Abnahme von Bogenoffsetdruckmaschinen. Bundesverband Druck/FOGRA, Wiesbaden 1996.
- MacPhee, J.: GATF hot topics: Streaks in printing and how to resolve them. GATF, Pittsburgh (PA) 1994.
- Pietsch, R.; Dolezalek, E.: Druckform-Herstellung Offset. Polygraph-Verlag, Frankfurt/Main 1990.
- Riedl, R. et al.: Technologie des Offsetdrucks. Beruf und Schule, Itzehoe 1989.

Teschner, H.: Offsetdrucktechnik. 10. Aufl. Fachschriften-Verlag, Fellbach 1997.  
Walenski, W.: Einführung in den Offsetdruck. Hans Eggen GmbH, Hannover 1975.

### for 2.1.3

Frei, O.: Rollenoffset – Techniken, Systeme, Maschinen. Polygraph-Verlag, Frankfurt/Main 1979.  
MacPhee, J.: Fundamentals of lithographic printing. GATFPress, Sewickley (PA) 1998.  
Müller, A.; Drechsel, K.: Leitfaden der Offsettechnik. Polygraph-Verlag, Frankfurt/Main 1980.  
Teschner, H.: Offsetdrucktechnik. 10. Aufl. Fachschriften-Verlag, Fellbach 1997.

Walenski, W.: Der Rollenoffsetdruck. Fachschriften-Verlag, Fellbach 1995.

### for 2.1.4

Kipphan, H.: Color Measurement Methods and Systems in Printing Technology and Graphic Arts. Proceedings SPIE, Vol. 1912 (Color Hardcopy and Graphic Arts II). The Society for Optical Engineering (SPIE), Bellingham (WA) 1993, pp. 278–298.  
Kipphan, H.: Qualitäts- und Produktivitätssteigerung im modernen Offsetdruck. Das Papier, Sonderausgabe 10A, Okt. 1992.  
Kipphan, H.: Quality and Productivity Enhancement in Modern Offset Printing. Polygraph International, Special Print 3-93, 1993.